

RCM Modules (from firmware 2.20)

- 96-PA-RCM
- 96-PA-RCM-EL

Residual current expansion modules
for the UMG 96-PA (from firmware 2.0)
and UMG 96-PQ-L device series

User manual

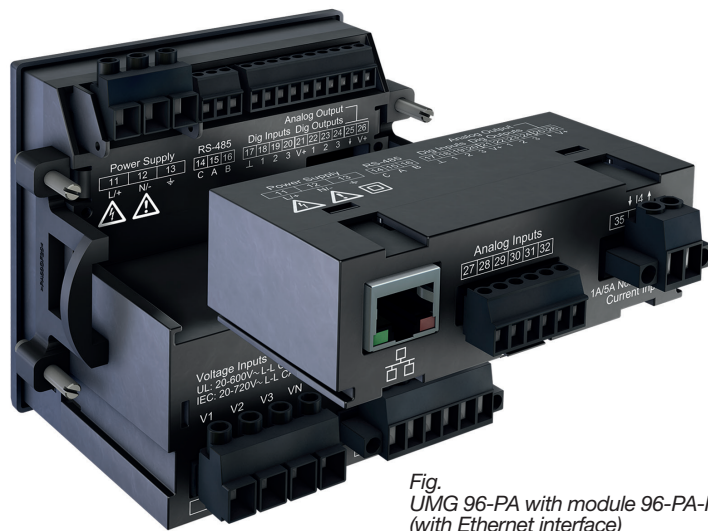

Fig.
UMG 96-PA with module 96-PA-RCM-EL
(with Ethernet interface)

Module 96-PA-RCM and 96-PA-RCM-EL,
RCM modules for extending the range of functions of the device series
UMG 96-PA (from firmware 2.0) and UMG 96-PQ-L

Doc. no.: 2.061.033.3.b

Date: 09/2023

The German version is the original edition of the documentation

Subject to technical alterations.

The contents of our documentation have been compiled with great care and reflect the current state of the information available to us. Nonetheless, we wish to point out that updates of this document are not always possible at the same time as technical refinements are implemented in our products. Information and specifications are subject to change without notice.

Please check for the latest version at www.janitza.com.

Information on the GridVis® software

 Janipedia: wiki.janitza.com

 Tutorials: youtube.com/@gridvis

Table of contents

1. Information on the device and the user manual	8
1.1 Disclaimer	8
1.2 Copyright notice	8
1.3 Technical changes	8
1.4 About this user manual	8
1.5 Defective device/disposal	9
2. Safety	10
2.1 Display of warning notices and safety information	10
2.2 Hazard levels	10
2.3 Product safety	10
2.4 Hazards when handling the device, components and modules	11
2.5 Electrically qualified personnel	12
2.6 Warranty in the event of damage	12
2.7 Safety information for handling current transformers and devices with residual current measurement	12
2.8 Safety information for analog inputs	13
3. Product description	14
3.1 Module description	14
3.2 Module's scope of functions	14
3.3 Incoming goods inspection	14
3.4 Intended use	15
3.5 Overview of module functions	15
3.6 EU/UK Declaration of Conformity	15
3.7 Scope of delivery	16
3.8 Operating concept	16
3.9 GridVis network analysis software	17
4. Mounting	18
4.1 Mounting requirements for the basic device for use with module	18
4.2 Module mounting	19
4.3 Module connections	20
4.4 Module markings – Rating plates	21

5. Installation	22
5.1 PC connection of the basic device	22
5.2 PC connection of the basic device with module via the Ethernet interface (only RCM-EL)	22
5.2.1 Ethernet direct connection	22
5.2.2 Connection as a gateway	22
5.2.3 Connection to a network	23
5.3 PC connection of the basic device with module via RS-485 interface (Modbus)	23
5.4 Connection variant with terminal assignment	24
5.5 Connection example of basic device with module	25
6. Inputs and interfaces	26
6.1 Analog inputs I5 and I6 – Residual current input/current signal input	26
6.2 Activate cable break detection (failure monitoring) RCM for I5 and I6	27
6.3 Current direction for the current transformer on I5 and I6	27
6.4 Important information about the residual current inputs	28
6.5 Residual current transformer example	28
6.6 Connection example 1 - Residual current measurement	29
6.7 Connection example 2 - Residual current measurement	29
6.8 Connection example 3 - Residual current monitoring	30
6.9 Residual current limit values	31
6.9.1 Example graph “Calculation of the dynamic residual current limit value”	31
6.9.2 Example graph “Calculation of the static residual current limit value”	32
6.9.3 Example graph “Calculation of the incremental residual current limit value”	32
6.10 Analog inputs I5 and I6/U6 – DC power	33
6.11 Connection example - DC power measurement	33
6.12 Current measurement input I4 – neutral conductor measurement	34
6.13 Temperature measurement input	35
6.14 Ethernet interface (only module 96-PA-RCM-EL)	36
7. Operation and button functions of the basic device with module	37
7.1 Operation	37
7.2 Button function	37
7.3 Measuring display	37
7.4 Menu	37
7.5 Overview of the additional menu items for basic devices with module	38

8. Communication	40
8.1 Basic device communication via the Ethernet interface (module 96-PA-RCM-EL)	40
8.1.1 Configuring Ethernet settings on the basic device	40
8.1.2 Configuring Ethernet settings via the GridVis® software	41
8.1.3 Configuring firewall settings via the GridVis® software	41
8.2 Basic device communication via the RS-485 interface (field bus)	42
8.3 Restarting the basic device	42
8.4 Module-relevant alarms	43
9. Module-relevant configuration	44
9.1 L4 current transformer (I4 - measurement)	44
9.2 Module mode	45
9.3 Temperature sensor	47
9.4 Modbus editor	47
9.5 Module-relevant configuration with the GridVis® software	48
10. Displays of the module	50
10.1 Current menu – L4 current measurement	50
10.2 Harmonics menu	50
10.3 Residual current menu	51
10.4 DC power menu	51
10.5 System Info menu	52
10.6 Configuration menu – without password/after password entry	53
11. Technical data for the module	54
11.1 Technical data	54
11.2 Performance characteristics of functions	56
12. Dimensional drawings and views	57
12.1 Dimensional drawings	57
12.2 3D views of basic device with module	57

13. Dismounting	58
14. Service and maintenance	59
14. 1 Repairs and calibration	59
14. 2 Service	59
14. 3 Device adjustment	59
14. 4 Calibration interval	59
14. 5 Firmware update	59
14. 6 Procedure in the event of a malfunction	59
14. 7 Resetting the module to the standard factory settings	59

1. Information on the device and the user manual

1.1 Disclaimer

Compliance with the usage information for the devices is a prerequisite for safe operation and attaining the stated performance characteristics and product features.

Janitza electronics GmbH assumes no liability for bodily injury, material damage or financial losses which result from disregard of the usage information.

Make sure that your usage information is readily available and legible.

1.2 Copyright notice

© 2023 - Janitza electronics GmbH - Lahnau.
All rights reserved.

Any reproduction, processing, distribution or other use, in whole or in part, is prohibited.

All trademarks and the rights arising from them are the property of the respective owners of these rights.

1.3 Technical changes

- Make sure that your device matches the user manual.
- First make sure you have read and understood the usage information accompanying the product.
- Keep the usage information associated with the product available for the entire service life and pass it on to any possible subsequent users.
- Find out about device revisions and the associated modifications of the usage information associated with your product at www.janitza.com.

1.4 About this user manual

If you have questions, suggestions or ideas for improvement of the user manual, please let us know via email at: info@janitza.com.

INFORMATION

This user manual describes the modules and provides information on the operation of the modules via the basic device (with the current firmware).

In addition to this user manual, refer to the usage information of your basic device, such as:

- User manual
- Installation manual
- “GridVis® Software” Quick Guide
- Safety information
- GridVis® online help

The device illustrations in this user manual show the UMG 96-PA as an example for the basic device in some applications and functions. The described applications and functions of the 96-PA-RCM and 96-PA-RCM-EL modules apply equally to the device series of the UMG 96-PA (from firmware 2.0) and UMG 96-PQ-L!

INFORMATION

Our usage information uses the grammatical masculine form in a gender-neutral sense! This form always refers equally to women, men and diverse. In order to make the texts more readable, distinctions are not made. We ask for your understanding for these simplifications.

1.5 Defective device/disposal

Before sending **defective devices, modules or components** back to the manufacturer for testing:

- Contact the manufacturer's Support department.
- Send devices, modules or components complete with all accessories.
- When doing so, please bear the terms for transportation in mind.

INFORMATION

Please return defective or damaged devices to Janitza electronics GmbH in accordance with the shipping instructions for air or road freight (complete with accessories).

Observe special regulations for devices with built-in batteries or rechargeable batteries!

Do not attempt to open or repair the device (the component) on your own because otherwise all warranty claims become invalid!

For the **Disposal** of the device please observe national regulations! Dispose of individual parts, as applicable, depending on their composition and existing country-specific regulations, e.g. as

- Electronic waste,
- Batteries and rechargeable batteries,
- Plastics,
- Metals.

Engage a certified disposal company to handle scrapping as needed.

Information on service and maintenance of your device can be found in chapter „14. Service and maintenance“ on page 59.

2. Safety

The chapter on Safety contains information which must be observed to ensure your personal safety and avoid material damage.

2.1 Display of warning notices and safety information

The warning notices shown below

- are found throughout the usage information.
- are on the devices, components and modules themselves,
- indicate potential risks and hazards,
- underscore aspects of the information provided that clarifies or simplifies procedures.



The additional symbol on the device itself indicates an electrical danger that can result in serious injuries or death.





This general warning symbol draws attention to a possible risk of injury. Be certain to observe all of the information listed under this symbol in order to avoid possible injury or even death.



2.2 Hazard levels

Warning and safety information is marked by a warning symbol, and the hazard levels are shown as follows, depending on the degree of hazard:

 DANGER
Warns of an imminent danger which, if not avoided, results in serious or fatal injury.
 WARNING
Warns of a potentially hazardous situation which, if not avoided, could result in serious injury or death.
 CAUTION
Warns of an immediately hazardous situation which, if not avoided, can result in minor or moderate injury.

ATTENTION

Warns of an immediately hazardous situation which, if not avoided, can result in material or environmental damage.

INFORMATION

Indicates procedures in which there is **no** hazard of personal injury or material damage.

2.3 Product safety

The device, the components and the modules reflect current engineering practice and accepted safety standards, but hazards can arise nonetheless.

Observe the safety regulations and warning notices. If notices are disregarded, this can lead to personal injury and/or damage to the product.

Every type of tampering with or use of this device, the components or the modules,

- which goes beyond the mechanical, electrical or other operating limits can lead to personal injury and/or damage to the product;
- constitutes “misuse” and/or “negligence” under the product’s warranty and thus voids the warranty for any possible resulting damage.

Read and understand the respective documentation and user manuals before installation, operation, maintenance and the use of this device, the components or the modules.

Only operate the device, components and modules when they are in perfect condition and in

compliance with this user manual and the associated, included documents. Send defective devices, components and modules back to the manufacturer in compliance with proper transport conditions.

Retain the user manual throughout the service life of the device or components and modules and keep it at hand for consultation.

When using the device, components or modules, also observe the legal and safety regulations for your system that are applicable for the respective use case.

2.4 Hazards when handling the device, components and modules

When operating electric devices, certain parts of these devices can conduct hazardous voltage. Consequently, material damage and bodily injury including death can occur if they are not handled properly.

Therefore, when handling our devices, components, and modules, always observe the following:

- Do not exceed the limit values specified in the user manual and on the rating plate; this must also be observed during testing and commissioning.
- Take note of the safety and warning notices in all documents that belong to the device, components or modules.

WARNING

Risk of injury due to electrical voltage!

Severe bodily injury or death can result! Therefore please abide by the following:

- Switch off your installation before commencing work! Secure it against being switched on! Check to be sure it is de-energized! Ground and short circuit! Cover or block off adjacent live parts!
- During operation and troubleshooting (especially for DIN rail devices), check your system for dangerous voltages and switch these off if necessary!
- Wear protective clothing and protective equipment in accordance with applicable guidelines when working on electrical systems!
- Before making connections to the device/the component, ground the device by means of the ground wire connection, if present.
- Do not touching bare or stripped leads that are energized! Equip stranded conductors with wire ferrules!
- Hazardous voltages can be present in all circuitry parts that are connected to the power supply.
- Protect wires, cables and devices with a suitable line circuit breaker/fuse!
- Never switch off, remove or tamper with safety devices!
- There can still be hazardous voltages present in the device or in the module even after disconnection from the supply voltage (capacitor storage).
- Do not operate equipment with current transformer circuits when open.
- Only connect screw terminals with the same number of poles and design!
- Do not exceed the limit values specified in the user manual and on the rating plate! This must also be observed during testing and commissioning.
- Take note of the safety and warning notices in the documents that belong to the device and modules!

2.5 Electrically qualified personnel

To avoid bodily injury and material damage, only electrically qualified personnel are permitted to work on the devices and their components, modules, assemblies, systems and current circuits who have knowledge of:

- The national and international accident prevention regulations.
- Safety technology standards.
- Installation, commissioning, operation, disconnection, grounding and marking of electrical equipment.
- The requirements concerning personal protective equipment.

Electrically qualified persons within the scope of the technical safety information of all documents associated with the devices and components/modules are persons who can furnish proof of qualification as an electrically skilled person.

WARNING

Warning against unauthorized manipulation or improper use of the device or its components and modules!

Opening, dismantling or unauthorized manipulation of the device and its components which goes beyond the mechanical, electrical or other operating limits indicated can lead to material damage or injury, up to and including death.

- Only electrically qualified personnel are permitted to work on the devices and their components, modules, assemblies, systems and current circuits.
- Always use your device, component or module only in the manner described in the associated documentation.
- If there is discernible damage, send the device, component or module back to the manufacturer!

2.6 Warranty in the event of damage

Any unauthorized tampering with or use of the device, component or module constitutes “misuse” and/or “negligence” under the product’s warranty and thus voids the warranty for any possible resulting damage. In this regard, please take note of chap. „3.4 Intended use“ on page 15.

2.7 Safety information for handling current transformers and devices with residual current measurement

WARNING

Risk of injury due to large currents and high electrical voltage on the current transformers!

Current transformers operated while open on the secondary side (high voltage peaks pose a hazard when touched) can result in severe bodily injury or death.

- Avoid operating the current transformers while open; short circuit the unloaded transformers!
- Before interrupting the current supply, short circuit the secondary connections of the current transformers. Switch any test switches that automatically short circuit the secondary lines of the current transformers to the “Test” status (Check the test switch/short circuiting connection beforehand)!
- Only use current transformers with basic insulation to IEC 61010-1:2010!
- Caution, even current transformers rated as safe for open operation can pose a hazard when touched during operation while open!
- Make sure that screw terminals for the current transformer connection on the device are adequately tightened!
- Comply with the information and provisions in the documentation of your current transformers!

⚠ CAUTION**Risk of injury or damage to the device due to high measurement currents on the connections of the current transformers!**

High measurement currents can cause temperatures of up to 80 °C (176 °F) on the connections of the current transformers

- Use wiring that is designed for an operating temperature of at least 80 °C (176 °F)!
- The current transformers can be hot even after the power supply has been switched off. Allow the connections of the current transformers and the connecting cables to cool down before touching them!

⚠ WARNING**Risk of injury or damage to the device due to improper use!**

Devices with residual current measurement can output warning pulses when limit values are exceeded. These serve the exclusive purpose of monitoring residual currents or failure monitoring. Use of the warning pulses as a stand-alone protective device against electrical shock can lead to injury or damage to the device or your system!

- Do not use devices with residual current measurement as a stand-alone protective device. Employ suitable protective devices for your system!

⚠ CAUTION**Risk of injury or damage to the device/your system due to short circuit!**

Inadequate insulation of the operating equipment at the residual current measurement input with respect to the supply circuits can cause voltages at the measurement input which represent a hazard when touched or damage to your device or system.

- Ensure reinforced or double insulation with respect to the supply circuits!
- Ensure galvanic isolation of the residual current measurement inputs from each other!

2.8 Safety information for analog inputs**ATTENTION****Transmission errors and damage to the device and its components!**

With cable lengths greater than 30 m (32.81 yd), there is a risk of transmission errors and damage to the device due to atmospheric discharge.

- Use shielded cables for connections to the analog inputs.
- Take suitable shielding measures for cable lengths greater than 30 m (32.81 yd)!
- Use the recommended cables and wires!

ATTENTION**Damage to the device/your system due to short circuit!**

Inadequate insulation of the operating equipment at the analog inputs with respect to the supply circuits can lead to damage of your device or system.

- Ensure reinforced or double insulation with respect to the supply circuits!

ATTENTION**Operational failures or damage to the device due to connection mistakes.**

The analog inputs are not short-circuit proof! Connection or wiring errors can lead to operational failures or damage to the device.

- When making connections, ensure correct wiring and observe the requirements for connections and the limit values!

3. Product description

3.1 Module description

The RCM module enhances the scope of functions of the basic device and is available in the following variants:

Part no.	Designation
5232011	96-PA-RCM
5232010	96-PA-RCM-EL (with Ethernet interface)

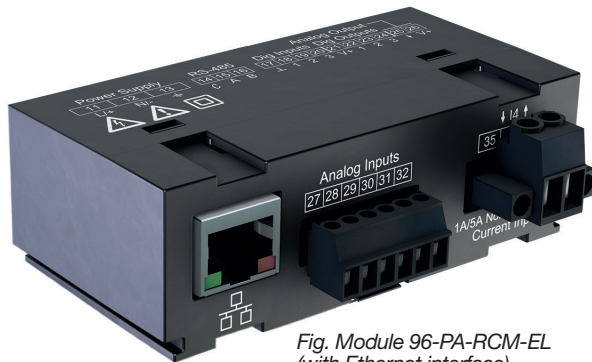

Fig. Module 96-PA-RCM-EL
(with Ethernet interface)

3.2 Module's scope of functions

- Neutral conductor measurement (I4 - current measurement).
- Residual current measurement (RCM) or DC power measurement via 2 analog inputs.
- Temperature measurement (1 analog input).

Both module variants are suitable for monitoring:

- Residual currents (RCM) - Type A, B and B+.
- AC currents.
- DC currents and pulsating DC currents.

The additional measurement results obtained from the module are output by basic device.

i INFORMATION

Because the modules are designed simply as plug-in modules (via a module connector) for one basic device, please also observe all usage information that belongs to your basic device! Take particular note of the insert entitled "Safety and warning notices"!

3.3 Incoming goods inspection

The prerequisites for trouble-free and safe operation of the modules include proper transport, storage, setup and assembly, as well as proper operation and maintenance.

Exercise due caution when unpacking and packing the device, do not use force and only use suitable tools.

Check the following:

- The modules by performing a visual inspection to ensure flawless mechanical condition.
- The scope of delivery (see user manual) with respect to completeness before beginning with assembly and installation.

If it must be assumed that safe operation of your basic device with module is not possible:

1. **Switch off the power to your system (your device)!**
2. **Secure it against being switched back on!**
3. **Check to be sure it is de-energized!**
4. **Ground and short circuit the system (device)!**
5. **Cover or block off adjacent live parts!**

Safe operation is impossible, if, for example, the device with module:

- has visible damage,
- no longer functions despite an intact power supply,
- was subjected to extended periods of unfavorable conditions (e.g. storage outside of the permissible climate thresholds without adjustment to the room climate, condensation, etc.) or transport stress (e.g. falling from an elevated position, even without visible external damage, etc.).

ATTENTION

Improper handling may cause damage to the module and result in material damage!

The contacts of the module connector can bend or break, which would destroy the module.

- Never touch or manipulate the contacts of the module connector!
- Never use force to press the module connector plug into the socket!
- When handling, transporting and storing the module, protect the contacts of the module connector!

3.4 Intended use

The **modules 96-PA-RCM** and **96-PA-RCM-EL**

- Are intended as plug-in modules for a basic device (of the UMG 96-PA or UMG 96-PQ-L device series) in switchboard cabinets and small distribution boards. The mounting orientation is arbitrary (please observe the usage information associated with the basic device).
- Must only be mounted on basic devices that are disconnected from the power supply (see “Mounting” step).

The basic device with attached module is **not**

- Intended for installation in vehicles! Use of the basic device with module in non-stationary equipment is considered an exceptional environmental condition and is only permissible by special agreement.
- Not intended for installation in environments with harmful oils, acids, gases, vapors, dusts, radiation, etc.

3.5 Overview of module functions

- 3 analog inputs for:
 - 2x residual-current and current measurement with cable break detection.
 - 1x temperature measurement
- I4 current measuring channel for I4 current measurement via a current transformer (.../5 A or .../1 A)

Communication:

- Modbus RTU protocol (RS-485 interface of the basic device).
- Only **Module 96-PA-RCM-EL**:
RJ45 Ethernet interface

Important module performance characteristics can be found in chap. „11. Technical data for the module“ on page 54.

3.6 EU/UK Declaration of Conformity

Please see the EU/UK Declaration of Conformity posted at www.janitza.com for the laws, standards and directives applied by Janitza electronics GmbH for the devices. The CE/UKCA conformity marking requirements for the device arise from the EU/UK conformity declaration and the laws, standards and directives mentioned therein.

3.7 Scope of delivery

Quantity	Part no.	Designation
1	5232011	Module 96-PA-RCM
or		
1	5232010	Module 96-PA-RCM-EL
1	3303374	Installation manual DE/EN
1	3303342	Safety information, 12 languages
1	5232252	Module 96-PA-RCM/EL accessory pack

Tab. Scope of delivery

The screw terminals required for the device are included in delivery.

3.8 Operating concept

There are several options for programming the device with module or reading out the measured values, e.g. via the

- buttons on the basic device,
- GridVis® network analysis software,
- RS-485 interface or Ethernet interface.

INFORMATION

Please observe the usage information of your basic device (without module)!

Basic or identical information and chapters, such as

- Commissioning
 - Configuration
 - Technical data
 - Error messages
 - Procedure in the event of a malfunction, etc.
- can be found in the usage information of your basic device.

A list of parameters and Modbus addresses with data on your basic device with module is available for you as a download at www.janitza.com.

3.9 GridVis network analysis software

With the GridVis® software, you have the perfect tool for programming, reading out and visualizing measurement data (download at www.janitza.com).

Performance characteristics of the GridVis® software

- Device configuration.
- Graphic display of measured values
- Report and read-out functions
- Alarm management.

Connections to the PC (GridVis® software)

Connections for communication between the PC and the device with module can be found in chap. „5. Installation“ on page 22.

INFORMATION

This user manual describes the module and provides information on the operation of the module via the basic device.
The GridVis® software has an “online help” feature.

ATTENTION

Material damage due to security vulnerabilities in programs, IT networks and protocols.

Security vulnerabilities can lead to data misuse and faults and even the standstill of your IT infrastructure.

To protect your IT system, network, data communications and measurement devices:

- Inform your network administrator and/or IT representative.
- Always keep the meter firmware up to date and protect the communication to the meter with an external firewall. Close unused ports.
- Take protective measures against viruses and cyber attacks from the Internet, e.g. through firewall solutions, security updates and virus protection programs.
- Eliminate security vulnerabilities and update or renew existing protection for your IT infrastructure.

4. Mounting

4.1 Mounting requirements for the basic device for use with module

To be able to use the **modules 96-PA-RCM and 96-PA-RCM-EL**, the basic devices of the **UMG 96-PA series** require **firmware from version 2.0 and hardware from version 4**.

The devices of the **UMG 96-PQ-L series** already have module capability in the standard version.

The **hardware version** of your basic device is specified on the rating plate. For more detailed information on this, refer to the user manual of your basic device.

You can check the installed **firmware version** in the user interface of your basic device under: *Menu > Configuration > System > Version*.

You can find the latest firmware as a download for your corresponding basic device at www.janitza.com.

Your Janitza partner or the support team are happy to be of assistance to you with regard to questions on updating the hardware version or firmware installation.



Fig.: Rating plate of the basic device with indication of the hardware version.

4.2 Module mounting

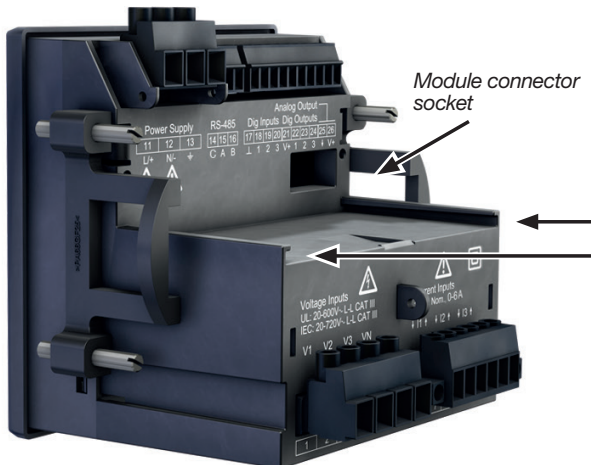

Fig. basic device

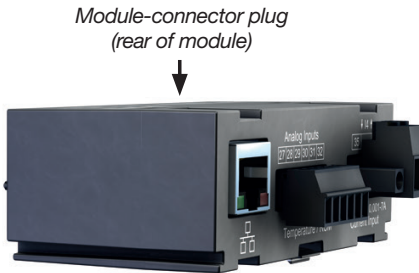

Fig. Module 96-PA-RCM-EL (with Ethernet interface)

Mounting module:

1. Disconnect the system (basic device) from the power supply!
2. Remove the transport protection from the module connector plug of the module and the protection from the module connector socket of the basic device.
3. Slide the module into the slot on the rear side of the basic device and use slight pressure to press it into the basic device until the module connector audibly snaps in.
4. Connect the system (basic device) to the power supply. The basic device recognizes the plugged in module automatically.

⚠ CAUTION

Disregard of the installation instructions may cause property damage or personal injury!

Disregarding the installation instructions may cause damage to your basic device with module or destroy it and/or may also result in personal injury.

- Observe the assembly instructions of your basic device.
- Disconnect your basic device from the power supply prior mounting the module!
- Provide adequate air circulation in your installation environment and cooling, as needed, when the ambient temperatures are high.
- Before mounting, remove the transport protection from the module connector plug of the module and the protection from the module connector socket of the basic device.

ⓘ INFORMATION

The basic device supports the module functions only if the module is detected during the startup process (e.g. residual current or DC power)! If there is no communication with the module:

- Disconnect your system (the basic device) from the power supply and check the positioning of the RCM module. Carefully press the module onto the basic device until it audibly snaps into place.
- If necessary, restart the basic device (section „8.3 Restarting the basic device“ on page 42)!
- If these measures are unsuccessful, please contact our support team (www.janitza.de)!

4.3 Module connections

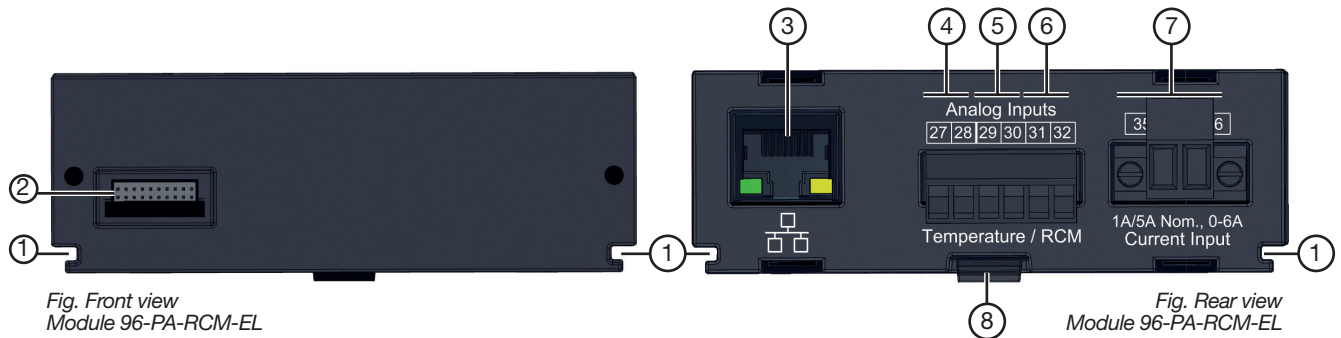

Item	Designation	Description
1	Groove	Guide groove for the mounting/dismantling of the module.
2	Module connector	Interface to basic device
3	RJ45	Only module 96-PA-RCM-EL: Ethernet interface (10/100Base-T)
4	Analog inputs - terminals 27 / 28	Temperature measurement
5	Analog inputs - terminals 29 / 30	Residual current measurement I5
6	Analog inputs - terminals 31 / 32	Residual current measurement I6 or voltage measurement U6 for the DC power.
7	Current measurement input - terminals 35 / 36	Current measurement I4 ¹⁾
8	Snap-in locking device	For the mounting/dismantling of the module (engaging/releasing).

¹⁾ In combination with **UMG 96-PQ-L-LP**, use the terminals 43 / 44 on the basic device for the I4 measurement.

4.4 Module markings – Rating plates

Module 96-PA-RCM

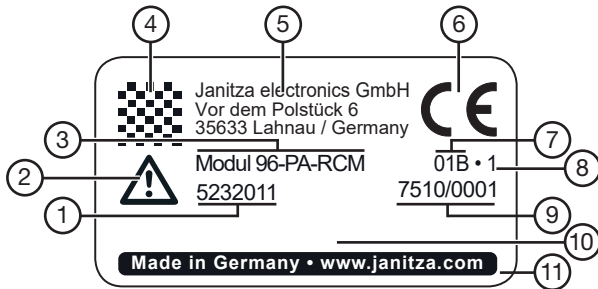

Module 96-PA-RCM-EL

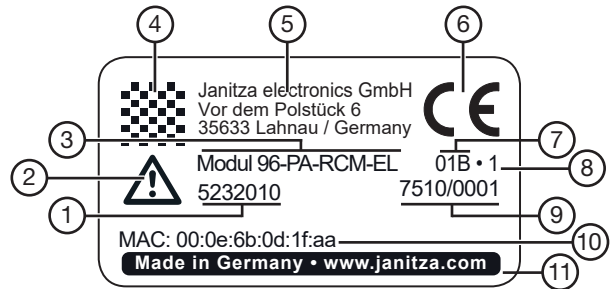

Item	Designation	Description
1	Part number	Manufacturer's part number
2	Symbol for "Danger sign"	General hazard symbol. Be certain to observe the warning notices applied to the device and shown in the documentation in order to avoid possible injury or even death.
3	Device type	Device designation
4	Data matrix code	Coded manufacturer data
5	Manufacturer's logo	Logo of the device manufacturer
6	CE conformity marking	See „3.6 EU/UK Declaration of Conformity“ on page 15
7	Manufacturer-specific data	Manufacturer data
8	Hardware version	Hardware version of the module
9	Type/serial number	Number for identification of the device
10	MAC address	Unique identification of the device in a computer network (only for module 96-PA-RCM-EL)
11	Designation of origin/web address	Country of origin and manufacturer's web address

5. Installation

5.1 PC connection of the basic device

The basic device with module can be connected to a PC in two ways:

1. **Ethernet interface (only RCM-EL)**
To configure and read data, connect your basic device via the Ethernet interface of module 96-PA-RCM-EL with the PC (GridVis® software).
2. **RS-485 interface**
Cf. Section 5.3 on page 23.

5.2 PC connection of the basic device with module via the Ethernet interface (only RCM-EL)

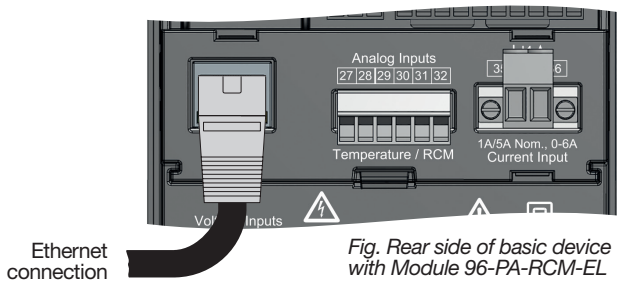

Fig. Rear side of basic device with Module 96-PA-RCM-EL

i INFORMATION

For communication, your basic device with module 96-PA-RCM-EL is equipped with

- 1 Ethernet interface and
- 1 RS-485 interface (field bus),

which you must configure in the *Communication* window.

For the PC connection via Ethernet, the basic device with the **96-PA-RCM-EL module** can be used as a gateway (client device).

ATTENTION

Material damage due to incorrect network settings.

Incorrect network settings can cause faults in the IT network!

Consult your network administrator for the correct network settings for your device.

5.1.1 Ethernet direct connection

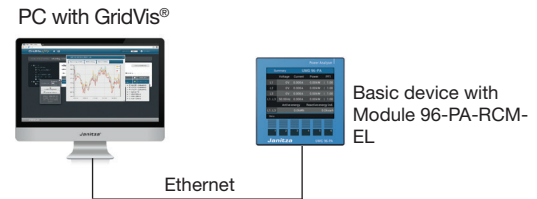

Fig. example: Basic device connected via the Ethernet interface of module 96-PA-RCM-EL as a direct connection

5.1.2 Connection as a gateway

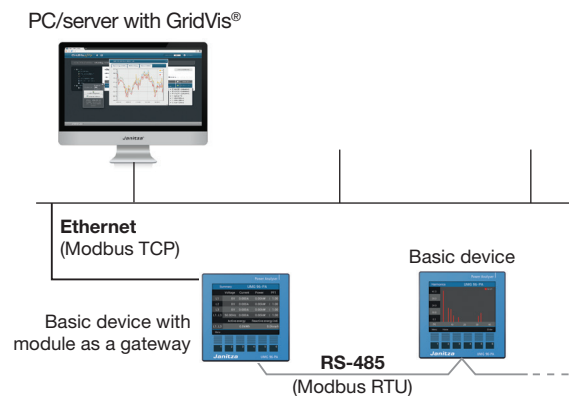

Fig. example: Connection of the basic device via the Ethernet interface of the 96-PA-RCM-EL module as a gateway between Modbus TCP and Modbus RTU

The gateway acts as a Modbus TCP server and as a Modbus RTU client. For operation as a gateway, navigate to and set *Configuration > Communication > RS-485 mode = Modbus Gateway* (see section „8.1.1 Configuring Ethernet settings on the basic device“ on page 40).

i INFORMATION

New terms of the Modbus organization!

- The **Modbus organization (modbus.org)** uses the terms "**client**" and "**server**" as a substitute for "master" and "slave".
- The client device initiates the communication and sends requests via Modbus.
- The server devices process the requests and return appropriate responses.

5.2.1 Connection to a network

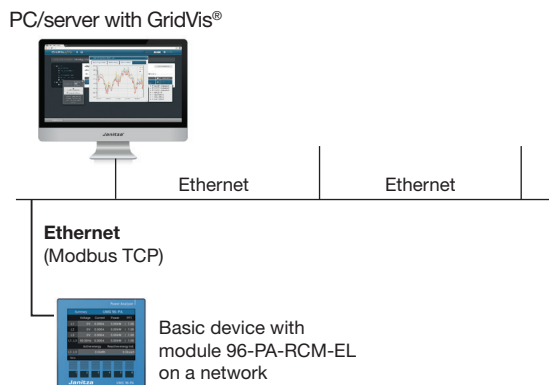

Fig. example: Basic device connected via the Ethernet interface of module 96-PA-RCM-EL to a network.

5.3 PC connection of the basic device with module via RS-485 interface (Modbus)

Another method of connecting the basic device with **module** to the PC (GridVis software), to configure it and read out the data is to use the **RS-485 interface** of the basic device.

Connect the basic device with **module 96-PA-RCM** to your PC via the RS-485 interface.

i INFORMATION

Detailed information on connection via the **RS-485 interface** of the basic device and to the RS-485 bus structure (Modbus) based on the client-server principle can be found in the usage information on the basic device.

5.4 Connection variant with terminal assignment

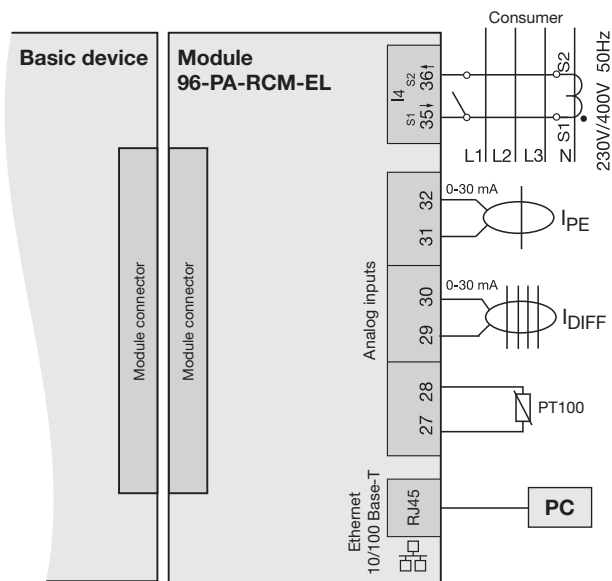

Fig. Connection variant: Residual current measurement, neutral conductor measurement I₄ and temperature measurement.

Terminal	Description	Mode
RJ45	Ethernet interface (only module 96-PA-RCM-EL)	
27 / 28	Temperature measurement	
29 / 30 and 31 / 32	Each with residual current measurement with cable break detection	Resid.current: 0-20 mA / 4-20 mA
or		
29 / 30 and 31 / 32	Residual current measurement (I _{DIFF}) and Current measurement PE (I _{PE}) (see left figure)	Resid.current: AC 0-30 mA _{rms}
or		
29 / 30 and 31 / 32	DC current measurement I ₅ and DC voltage measurement U ₆	DC power 0-20 mA / 4-20 mA
35 / 36	Current measurement I ₄ ¹⁾	

Tab. Terminal assignment

1) In combination with UMG 96-PQ-L-LP, connect the I₄ measurement to the basic device (terminals 43/44 instead of 35/36)!

i INFORMATION

Detailed information on voltage/current measurement and connection variants can be found in the basic device documentation.

Module mode and required transformers

The module supports three different modes for different applications:

Measuring ...	Module mode (Measuring mode)	Input signal	Required transformers
Residual current	RCM	0-20 mA / 4-20 mA	Active residual current transformers that, for example, output a DC signal of 20 mA at a 10 A current flow. Type B and B+ residual currents can be detected using appropriate active transformers. Select input signal of 0..20 or 4..20 mA according to the transformer rating plate.
	AC	0-30 mA _{rms}	Passive residual current transformers with a transformer ratio (e.g. 700:1) that deliver an AC signal.
Direct current, direct voltage. Calculation of power and energy from this.	DC Power	0-20 mA / 4-20 mA	<ul style="list-style-type: none"> · CH1: Current transformer (I₅) · CH2: Voltage/current transformer (U₆) to convert the voltage to be measured into a proportional current signal. The primary to secondary transformer ratio must be set correctly for both transformers.

Tab. Module mode and required transformers

5.5 Connection example of basic device with module

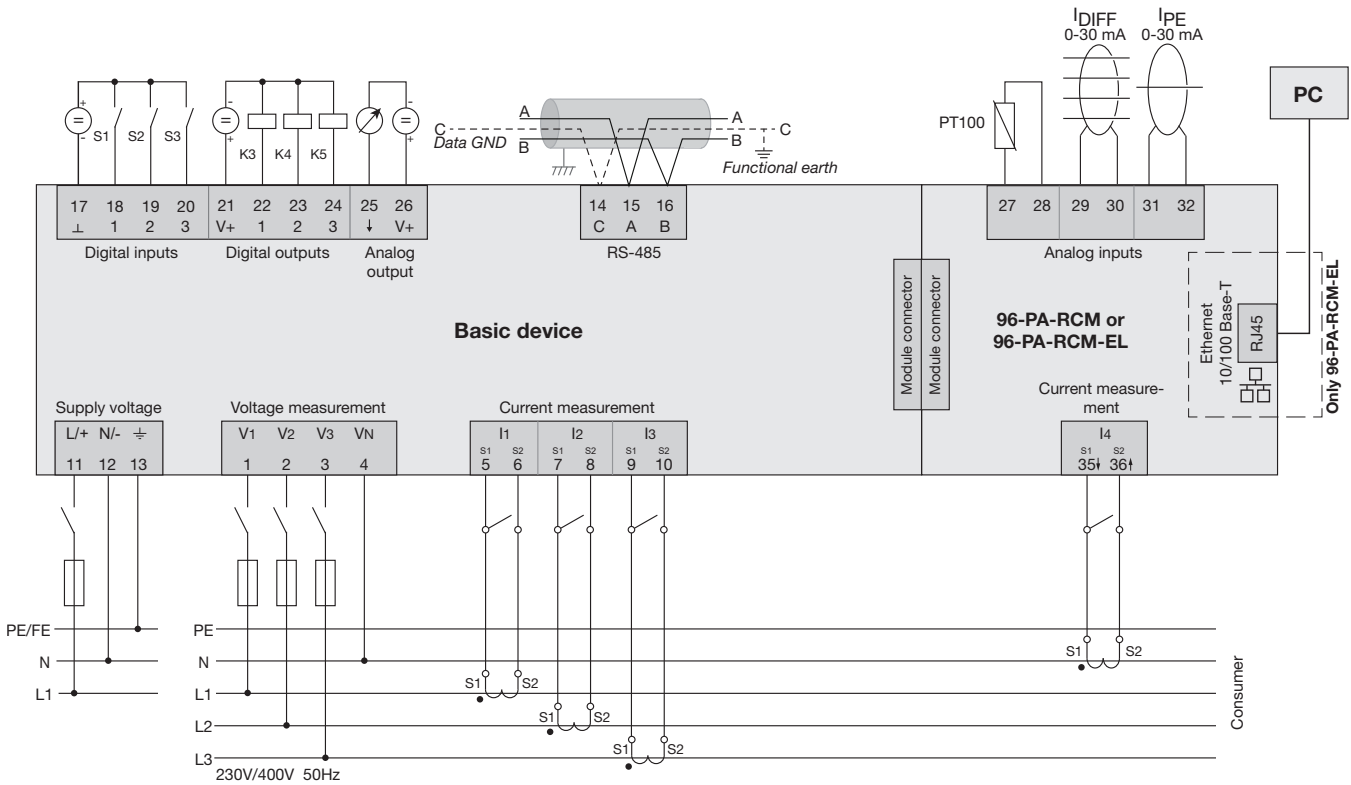

Fig. Connection example "Basic device with module 96-PA-RCM-EL"
 Information on overcurrent devices can be found in the user manual of your basic device

6. Inputs and interfaces

6.1 Analog inputs I5 and I6 – Residual current input/current signal input

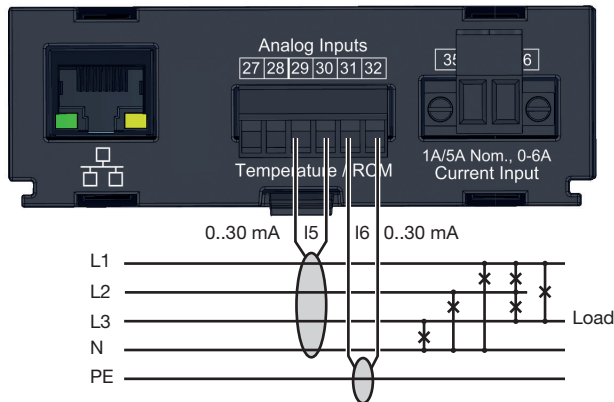

Fig. Connection variant, residual current measurement via current transformer (Type A).

The basic device with module is suitable for use as a residual current monitoring device (RCM) for monitoring alternating currents, pulsating direct currents and direct currents.

With the monitoring of residual currents (RCM, Residual Current Monitor) of an electrical system via inputs I5 and I6 (terminals 29/30 and 31/32), the basic device with module is able to trigger warning pulses when the limit value is exceeded. The system operator can be alerted before a protective device is triggered.

The measurements in medium and high voltage networks are made via current and voltage transformers.

i INFORMATION

- The residual current measurement monitors the residual currents via external current transformers and, if a threshold value is exceeded, can trigger a warning signal.
- Limit values and warnings for the device or system operator can be configured easily in the GridVis[®] software.

i INFORMATION

The basic device with module is not an independent protective device against electric shock!

The basic device with module measures residual currents according to IEC/TR 60755 (2008-01) of:

 Type A

 Type B and Type B+ ¹⁾

¹⁾ B+ means extended frequency range, residual current transformers of the B+ type required.

Connection of suitable external residual current transformers with a nominal current of 30 mA can be made on residual current transformer inputs I5 (terminals 29/30) and I6 (terminals 31/32).

6.2 Activate cable break detection (failure monitoring) RCM for I5 and I6

The basic device with module has a “Cable break detection” feature (failure monitoring). With this feature, the basic device with module monitors the connection to the residual current transformers on the measurement inputs I5 and I6 (module mode *Residual current* - see chap. 9.2 on page 45).

The cable break detection for I5 and I6:

- Can be activated via **Modbus addresses** or in the **GridVis®** software.
- Is **only available in the AC mode**.

Modbus addresses for activating the cable break detection (failure monitoring):

Modbus addr.	Measurement input	Value/function
20051	I5	0 = Failure monitoring inactive
20052	I6	1 = Failure monitoring active

You can check whether the cable break detection is activated in the user interface of your basic device with module under *Menu > Configuration > Measurement > item Residual current*.

If there is an interruption in the connection to the current transformers, the following Modbus addresses of the respective measurement inputs (I5 and I6) indicate the fault:

Modbus addr.	Measurement input	Value/function
20418	I5	0 = Connection to residual current transformer error free
20618	I6	1 = Error in the connection to the residual current transformer

The GridVis® software also displays the interruption in the connection.

INFORMATION

Further Modbus addresses can be found in the Modbus address list for the device (download at www.janitza.com).

6.3 Current direction for the current transformer on I5 and I6

For residual current measurements at the measurement inputs I5 and I6, the device makes no distinction between the current directions. This means that incorrect connection does not require reconnection afterwards.

INFORMATION

The device makes no distinction between the current directions of the residual currents. The residual currents of the grid side or load side are **not directionally sensitive**.

WARNING

Risk of injury due to large currents and high electrical voltage on the current transformers!

Current transformers operated while open on the secondary side (high voltage peaks pose a hazard when touched) can result in severe bodily injury or death.

- **Avoid operating the current transformers while open; short circuit the unloaded transformers!**
- **Before interrupting the current supply, short circuit the secondary connections of the current transformers. Switch any test switches that automatically short circuit the secondary lines of the current transformers to the “Test” status (Check the test switch/short circuiting connection beforehand!)**
- **Only use current transformers with basic insulation to IEC 61010-1:2010!**
- **Caution, even current transformers rated as safe for open operation can pose a hazard when touched during operation while open!**
- **Make sure that screw terminals for the current transformer connection on the device are adequately tightened!**
- **Comply with the information and provisions in the documentation of your current transformers!**
- **Ground connections present on the secondary windings of the current transformers must be connected to ground!**
- **Observe the general safety information for handling current transformers and devices with residual current measurement in chap. 2.7 on page 23.**
- **Comply with the information and provisions in the documentation of your current transformers!**

ATTENTION**Damage to the device/your system due to short circuit!**

Inadequate insulation of the operating equipment at the analog inputs with respect to the supply circuits can lead to damage of your device or system.

- **Ensure reinforced or double insulation with respect to the supply circuits!**

6.4 Residual current transformer example

A residual current transformer is used to measure on insulated mains wiring in a 300 V CAT III network.

Solution:

Provide basic insulation for 300 V CAT III for the insulation of the network wiring and the insulation of the residual current transformer. This corresponds to a test voltage of 1500 V AC (1 min. duration) for the insulated network wiring and a test voltage of 1500 V AC (1 min. duration) for the residual current transformer.

6.5 Important information about the residual current inputs**⚠ CAUTION****Risk of injury or damage to the device/your system due to short circuit!**

Inadequate insulation of the operating equipment at the residual current measurement input with respect to the supply circuits can cause voltages at the measurement input which represent a hazard when touched or damage to your device or system.

- **Ensure reinforced or double insulation with respect to the supply circuits!**
- **Ensure galvanic isolation of the residual current measurement inputs from each other!**

ⓘ INFORMATION

For the residual current monitoring, the basic device with module requires the mains frequency. For this purpose, apply a measured voltage or configure a fixed frequency.

ⓘ INFORMATION

The ratios for the residual current transformer inputs can be configured individually on the basic device with module, or, along with additional parameters relevant for the module, via the GridVis® network visualization software.

6.6 Connection example 1 - Residual current measurement

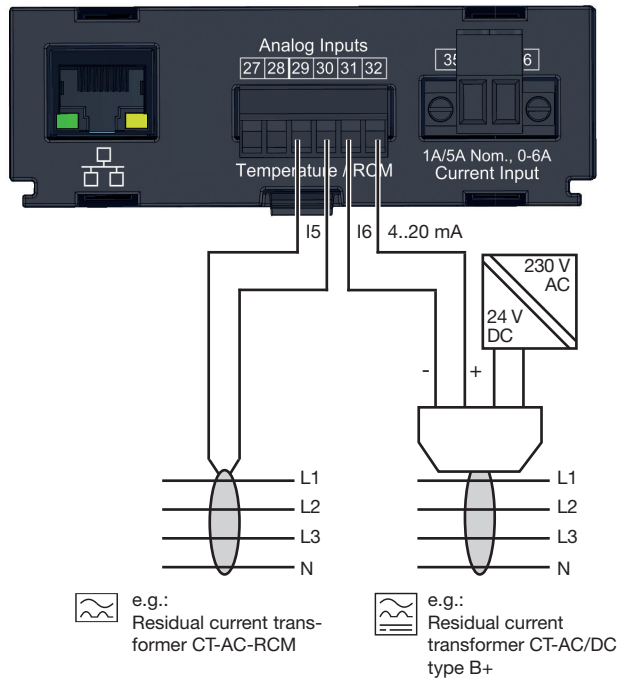

Fig. Connection variant, residual current measurement via current transformer type A and type B.
Power supply: $U = 24 \text{ V DC}$, residual ripple $< 5\%$, power = 24 W.

6.7 Connection example 2 - Residual current measurement

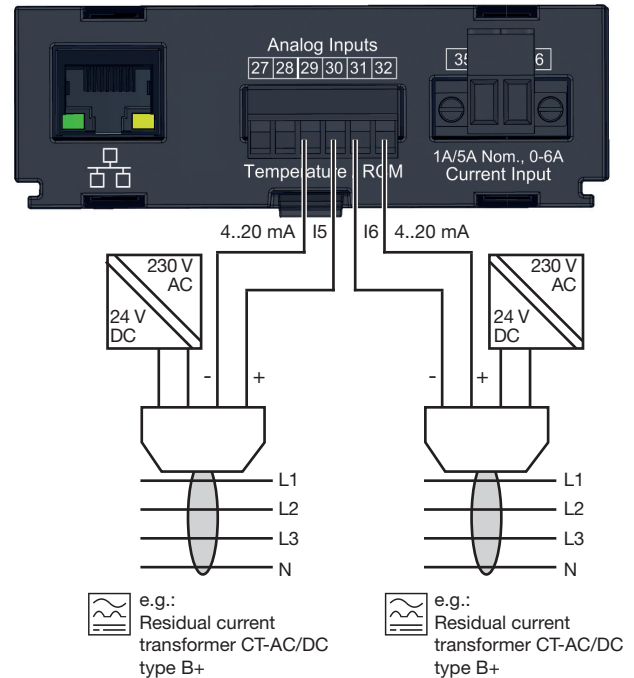

Fig. Connection variant, residual current measurement using a current transformer of type B.
Each residual current transformer of the series CT-AC/DC type B+ RCM requires its own power supply ($U = 24 \text{ VDC}$, residual ripple $< 5\%$, power = 24 W).
Electrically insulate the secondary sides of the power supplies from each other (24 V DC)!

6.8 Connection example 3 - Residual current monitoring

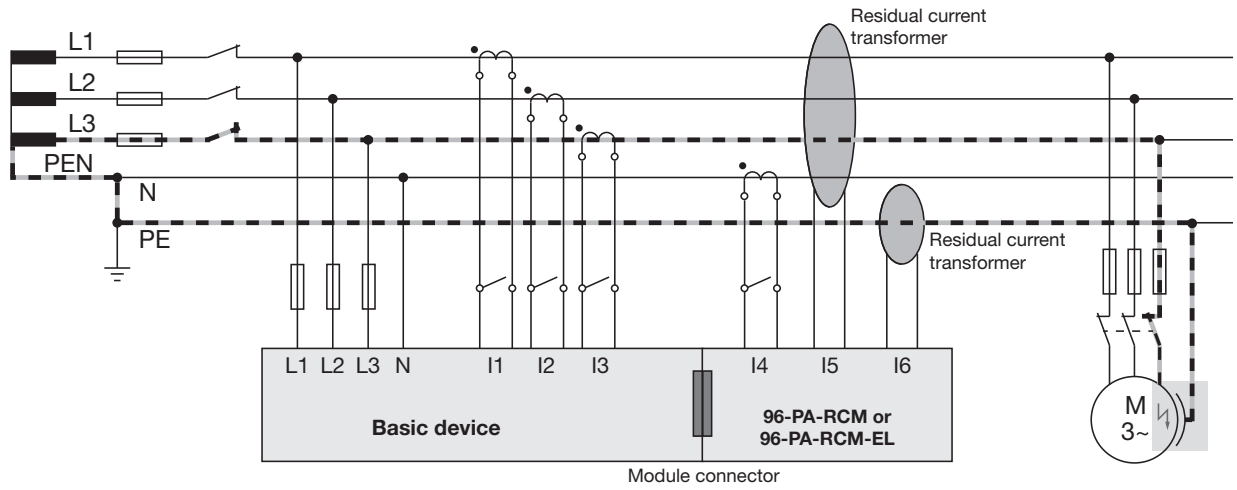

Fig. Connection example for residual current monitoring of a basic device with module

6.9 Residual current limit values

For setting and calculation of the residual current limit value, the basic device with module requires parameters which are set in the **GridVis®software**. Depending on the mode, the limit value calculation requires the following parameters:

1. "Calculation of the dynamic residual current limit value"

- Minimum overrun time.
- Maximum for the residual current.
- Warning when the set percent value of the calculated dynamic residual current limit value is reached (cf. section 2.7 on Page 12).
- Reference value.
- Tolerated residual current (dynamic value per reference value unit).
- Residual current pro consumer.
- Number of consumers.
- Offset for residual current measurement.

2. "Calculation of the static residual current limit value"

- Minimum overrun time.
- Warning when the set percent value of the static residual current limit value is reached.
- Residual current limit value

3. "Calculation of the incremental residual current limit value"

- Minimum overrun time.
- Warning when the set percent value of the incremental residual current limit value is reached.
- Reference value.
- Input of up to 10 residual current limit values for the respective power levels (increments).

6.9.1 Example graph "Calculation of the dynamic residual current limit value"

The example graph shows the relationship between the permitted residual current and the reference value power (of the system) with the following settings:

- Reference value: Power in kW
- Dynamic scaling: 10 mA / kW
- Absolute maximum for residual current: 200 mA
- Offset for residual current measurement: 20 mA

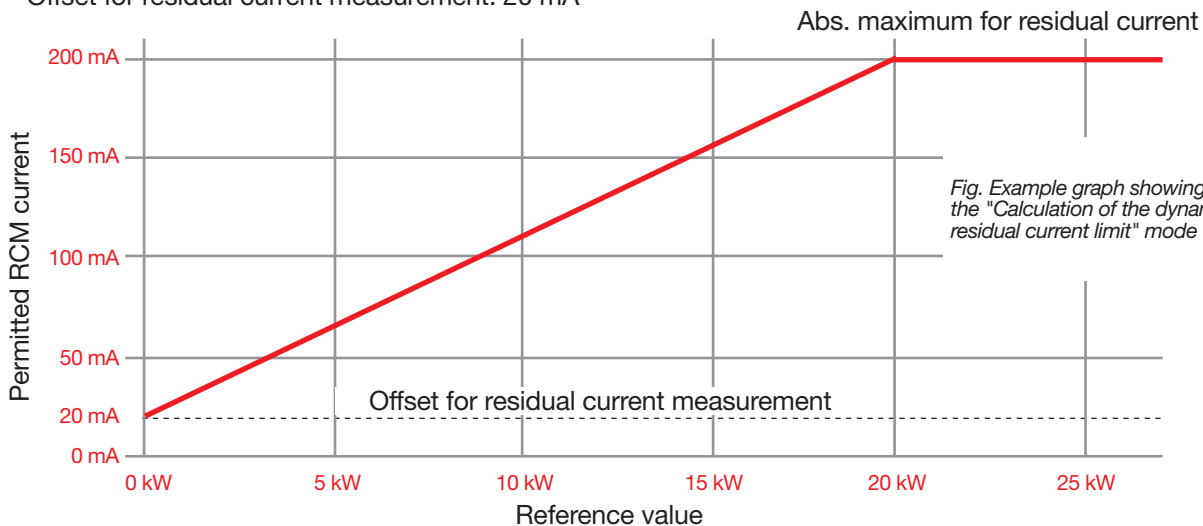

Fig. Example graph showing the "Calculation of the dynamic residual current limit" mode

The graph shows the user of the function:

- That the dynamic limit value calculation is active (static limit value calculation = horizontal line).
- The permitted residual current (RCM current) per power reference value.
- At what power reference value the maximum for the RCM current is reached.

6.9.2 Example graph "Calculation of the static residual current limit value"

The example graph shows a static residual current limit value that applies for every nominal current value (of the system):

- Nominal current reference value (not configurable).
- Residual current limit value: 300 mA.

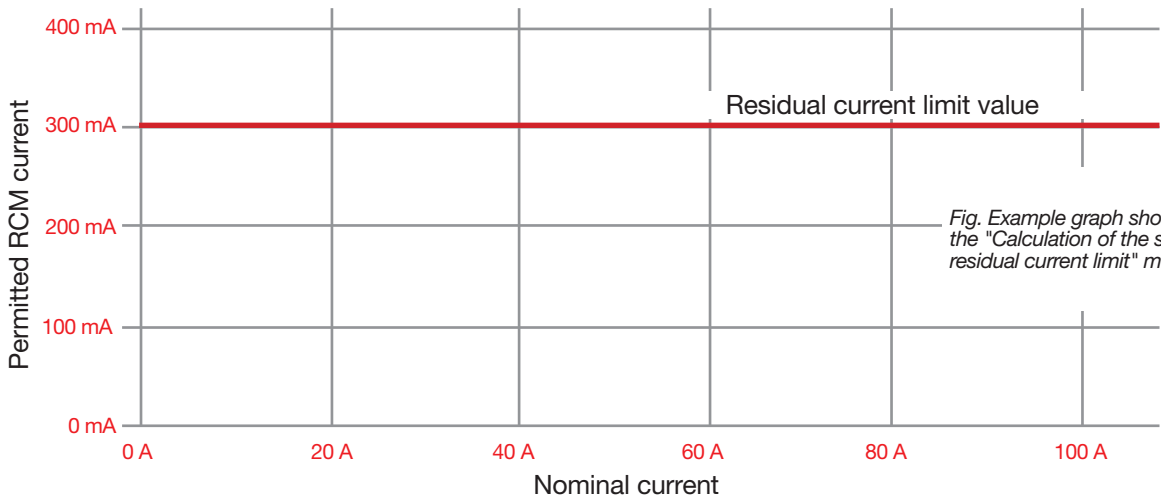

Fig. Example graph showing the "Calculation of the static residual current limit" mode

The graph shows the user of the function:

- That the static limit value calculation is active.
- The permitted residual current (RCM current) of the system.

6.9.3 Example graph "Calculation of the incremental residual current limit value"

The example graph shows the incremental increase of the residual current limit values of the power reference value (of the system) with the following increments (power levels):

- Reference value: Power in kW.
- Residual current limit value per power level: 50 mA.

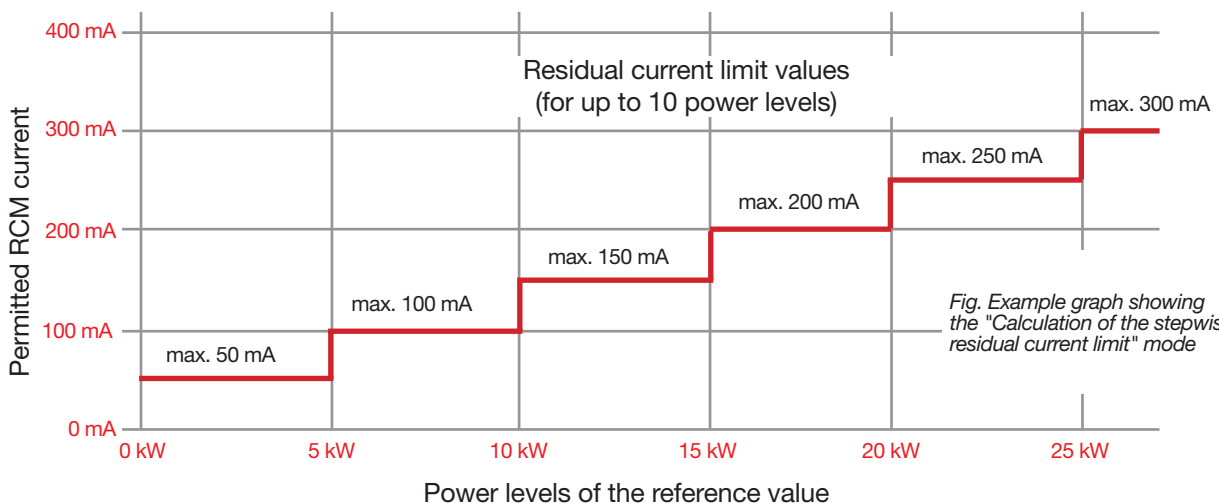

Fig. Example graph showing the "Calculation of the stepwise residual current limit" mode

The graph shows the user of the function:

- The incremental limit value calculation is active.
- The permitted residual current (RCM current) of the system per increment (power level).

6.10 Analog inputs I5 and I6/U6 – DC power

As an option for measuring the residual current, the basic device with module also permits use of the analog inputs I5 and I6 (U6) for a DC power measurement.

In a DC power measurement, the current channel I6 effectively becomes a voltage measurement input, U6. When a residual current transformer of the type CT-AC/DC Type B+ is connected, it converts an input voltage into an output current signal. The current signal changes proportionately to the measured value of the input variable.

For a DC power measurement, the basic device with module supports input current signals with the values

- 0 ... 20 mA
- 4 ... 20 mA

ATTENTION

Damage to the device/your system due to short circuit!

Inadequate insulation of the operating equipment at the analog inputs with respect to the supply circuits can lead to damage of your device or system.

- **Ensure reinforced or double insulation with respect to the supply circuits!**
- **Observe the general safety information in „2.8 Safety information for analog inputs“ on page 13.**

6.11 Connection example - DC power measurement

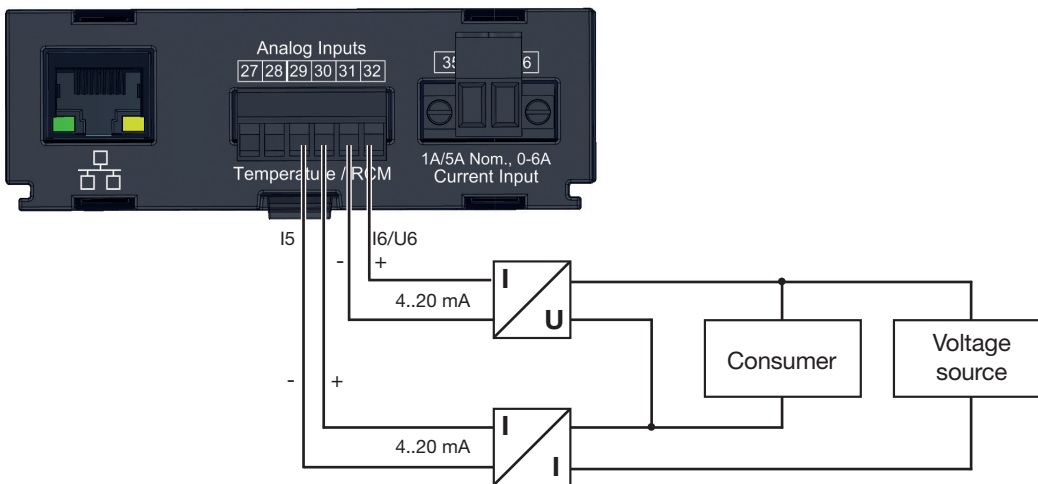

Fig. Connection variant, DC power measurement via current transformer and DC voltage sensor

6.12 Current measurement input I4 – neutral conductor measurement

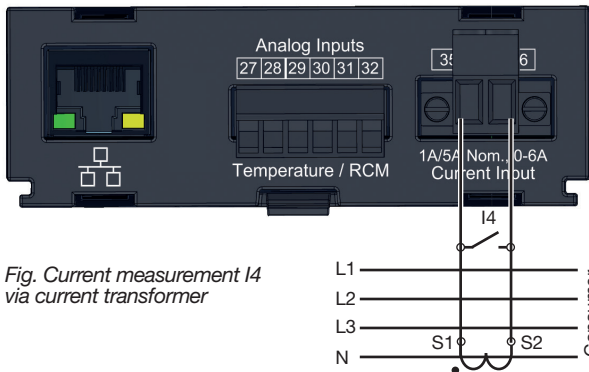

Fig. Current measurement I4 via current transformer

Because of the missing multiplier with a voltage, only an apparent current measurement is performed during the current measurement input I4 (terminals 35/36). Therefore, no power measurements are possible using this input.

The current measurement input I4 of the basic device with module:

- Is **only** approved for a current measurement using a current transformer (**no** direct measurement).
- Is designed for the connection of current transformers with secondary currents of $\dots/1$ A and $\dots/5$ A.
- Has the current transformer ratio set to 5 / 5 A by default.
- Measures alternating currents (**no** direct currents).

i INFORMATION

Because of the missing multiplier with a voltage, only an apparent current measurement is performed during the current measurement input I4. Therefore, no power measurements are possible using this input.

The current transformer ratio of the I4 current measurement input of your basic device with module can be configured in the **user interface of your basic device** or in the **GridVis®** software.

⚠ CAUTION

Risk of injury or damage to the device due to high measurement currents at the connections of the current transformers or the current measurement inputs of the device!

High measurement currents can cause temperatures of up to 80 °C (176 °F) on the connections of the current transformers

- **Use wiring that is designed for an operating temperature of at least 80 °C (176 °F)!**
- **The current transformers can be hot even after the power supply has been switched off. Allow the connections of the current transformers and the connecting cables to cool down before touching them!**
- **When fastening the current transformers, observe the tightening torques for the module's terminals!**
- **Ground connections present on the secondary windings of the current transformers must be connected to ground!**
- **Observe the general safety information for handling current transformers and devices with residual current measurement in section 2.7 on Page 12.**
- **Comply with the information and provisions in the usage information of your current transformers!**

6.13 Temperature measurement input

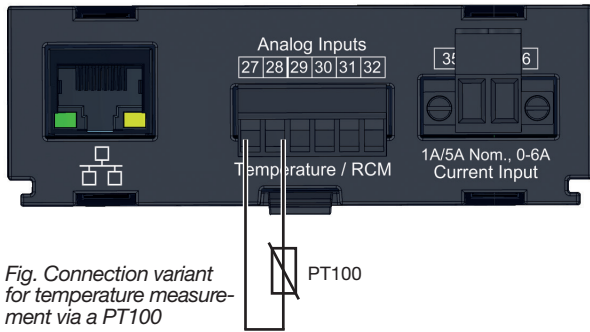

Fig. Connection variant for temperature measurement via a PT100

With a module, the basic device is equipped with a temperature measurement input. Temperature measurement is carried out via the analog input on terminals 27 and 28.

The measured values of the thermistor input are obtained through determination of the average value from cumulated resistance values. The average value is converted to a temperature value in the basic device and is displayed.

The basic device with module supports the following temperature sensors:

- PT100 (default setting)
- PT1000
- KTY83
- KTY84

ATTENTION

Damage to the basic device, the module and/or your system due to short circuit!

Inadequate insulation of the operating equipment (such as temperature sensor) at the analog inputs with respect to the supply circuits can cause damage to your basic device, module and/or system.

- **Ensure a reinforced or double insulation of your operating equipment with respect to the supply circuits!**
- **Use shielded lines to connect the temperature sensor!**
- **Do not exceed a total load of 4 k Ω (temperature sensor and cable)!**

Example of temperature sensor:

A temperature sensor is used for measurement in the proximity of non-insulated mains wiring in a 300 V CAT III network. Solution:

Use reinforced or doubled insulation for the temperature sensor for the 300V CAT III network! This corresponds to a test voltage of 3000 V AC (1 min. duration) for the temperature sensor.

6.14 Ethernet interface (only module 96-PA-RCM-EL)

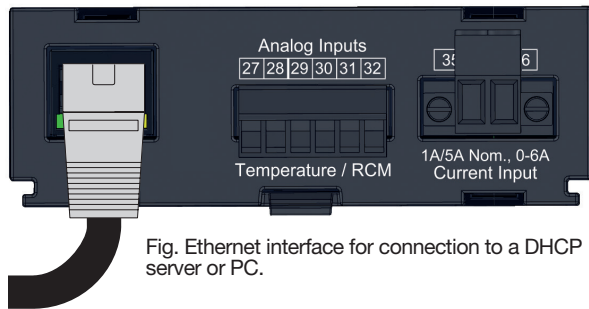

Fig. Ethernet interface for connection to a DHCP server or PC.

The PC connection to the GridVis® software can be made for the basic device with module 96-PA-RCM-EL via the Ethernet interface.

When connecting the Ethernet interface, ensure there is sufficient space in the connection area (at least 50 mm), depending on the bending radius and the plug type of the Ethernet cable. More information on the Ethernet connection can be found in the chap. „5.1 PC connection of the basic device“ on page 22.

The communication settings for the Ethernet connection of your basic device with module 96-PA-RCM-EL can be found in chap. „8.1 Basic device communication via the Ethernet interface (module 96-PA-RCM-EL)“ on page 40.

ATTENTION

Material damage due to incorrect network settings.

Incorrect network settings can cause faults in the IT network!

Consult your network administrator for the correct network settings for your device.

Meaning of the LEDs

LED	Function
Green	Is illuminated when there is a connection (link)
Yellow	Blinks during network activity

i INFORMATION

- Use a CAT5 cable for the connection to the Ethernet interface.
- The standard factory setting of the basic device with module is DHCP (dynamic assignment of IP address)! More information on the communication settings of the basic device with module can be found in chap. „8.1 Basic device communication via the Ethernet interface (module 96-PA-RCM-EL)“ on page 40.
- The Ethernet settings can be easily configured in the GridVis® software.
- The transmission of the time of a client device to server devices can only be configured in the GridVis® software.

7. Operation and button functions of the basic device with module

7.1 Operation

The device is operated via the 6 function buttons on the basic device:

- Selecting measuring displays.
- Navigation within the menus.
- Configuration of the measurement device.

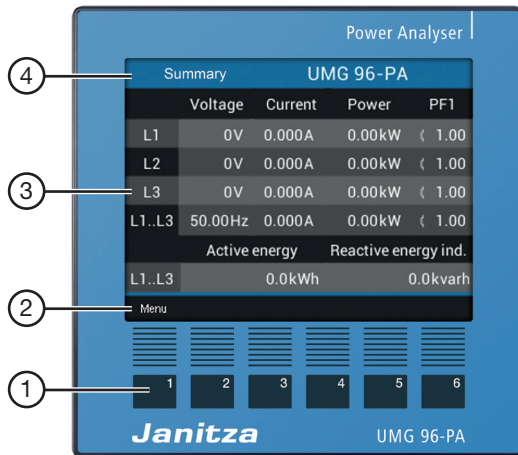

Fig. Example of basic device - measuring display

Item	Description
1	Function buttons
2	Function button labeling/symbols
3	Measured value display
4	Title displayed

7.2 Button function

Button	Function
1	<ul style="list-style-type: none"> • Display Menu • Exit Menu • Cancel action (ESC)
2	<ul style="list-style-type: none"> • Go to the start screen. • Select position (to the left “◀”) • Configuration of a measuring display as the start screen (press until message appears).
3	<ul style="list-style-type: none"> • Select menu item or position (down “▼”) • Change (selection, number -1)
4	<ul style="list-style-type: none"> • Select menu item or position (up “▲”) • Change (selection, number +1)
5	<ul style="list-style-type: none"> • Select position (to the right “▶”)
6	<ul style="list-style-type: none"> • Confirm selection (Enter)

7.3 Measuring display

After a network recovery, the **basic device with module** starts with the start screen (measured value display *Summary*).

Home		UMG 96-PA			
	Voltage	Current	Power	PF1	
L1	0V	0.000A	0.00kW	◀ 1.00	
L2	0V	0.000A	0.00kW	◀ 1.00	
L3	0V	0.000A	0.00kW	◀ 1.00	
L1..L3	50.00Hz	0.000A	0.00kW	◀ 1.00	
	Active energy		Reactive energy ind.		
L1..L3	0.0kWh		0.0kvarh		
Menu					

Fig. Measuring display “Overview” - measurement in a three-phase four-wire network (default setting).

In the as-delivered condition of the basic device with module, the title of the start screen consists of the device type and the serial number.

7.4 Menu

Pressing button 1 opens the *Menu* containing the selection of all parameters and measured variables to be set (menu items).

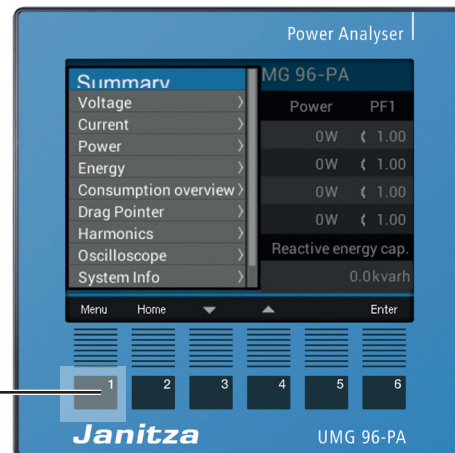

Fig. example measured value display *Summary* with scroll menu

Button 1 Menu

ⓘ INFORMATION

You can find detailed information on operation, measuring displays and button functions in the usage information for your basic device.

7.5 Overview of the additional menu items for basic devices with module

Menu

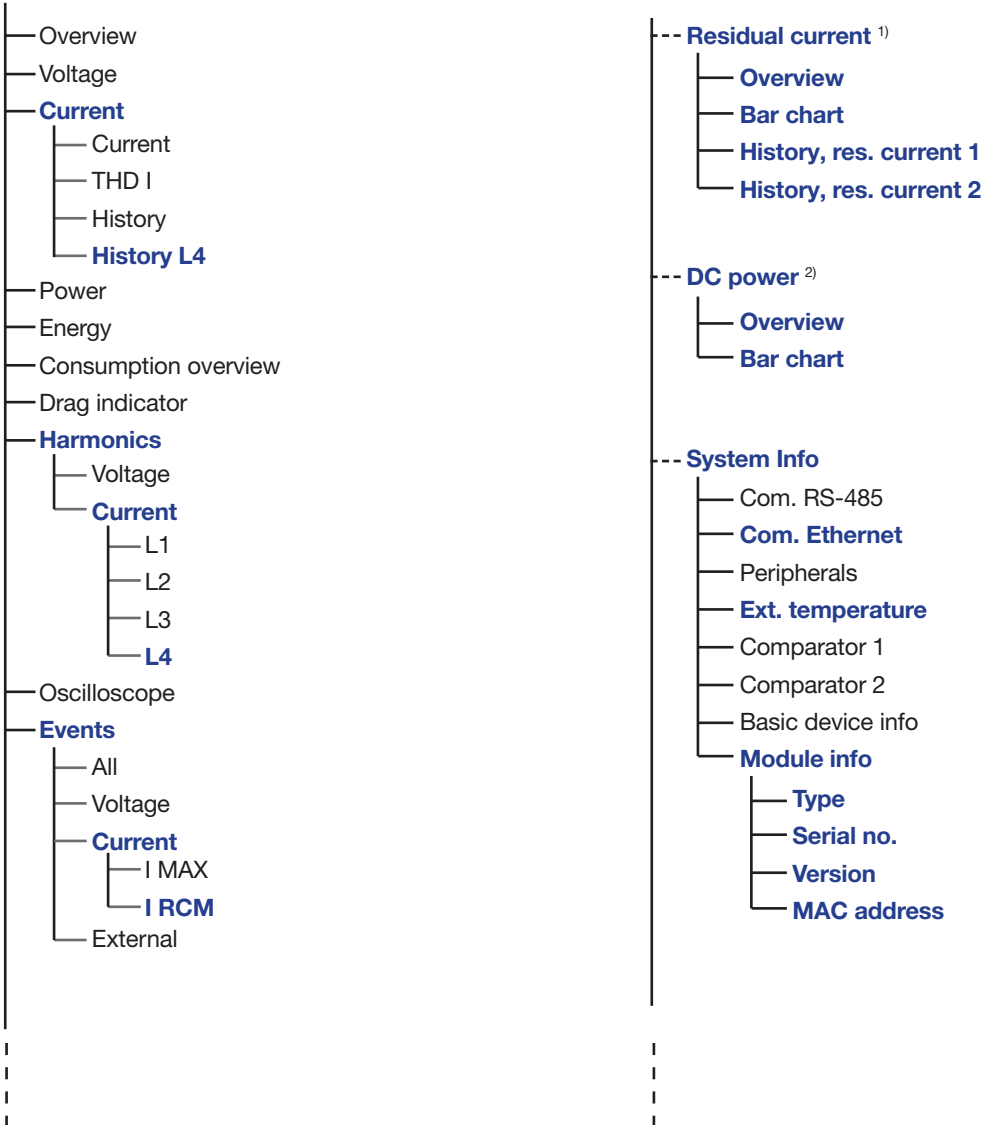

i INFORMATION

The menu entries of the basic devices may differ depending on the device type, firmware version and options (e.g. class S activation for the UMG 96-PQ-L). Please refer to the usage information of your basic device for this!

¹⁾ Only available in **residual current** module mode.

²⁾ Only available in **DC power** module mode.

The entries highlighted in **dark blue** indicate the additional or changed menus for the RCM module.

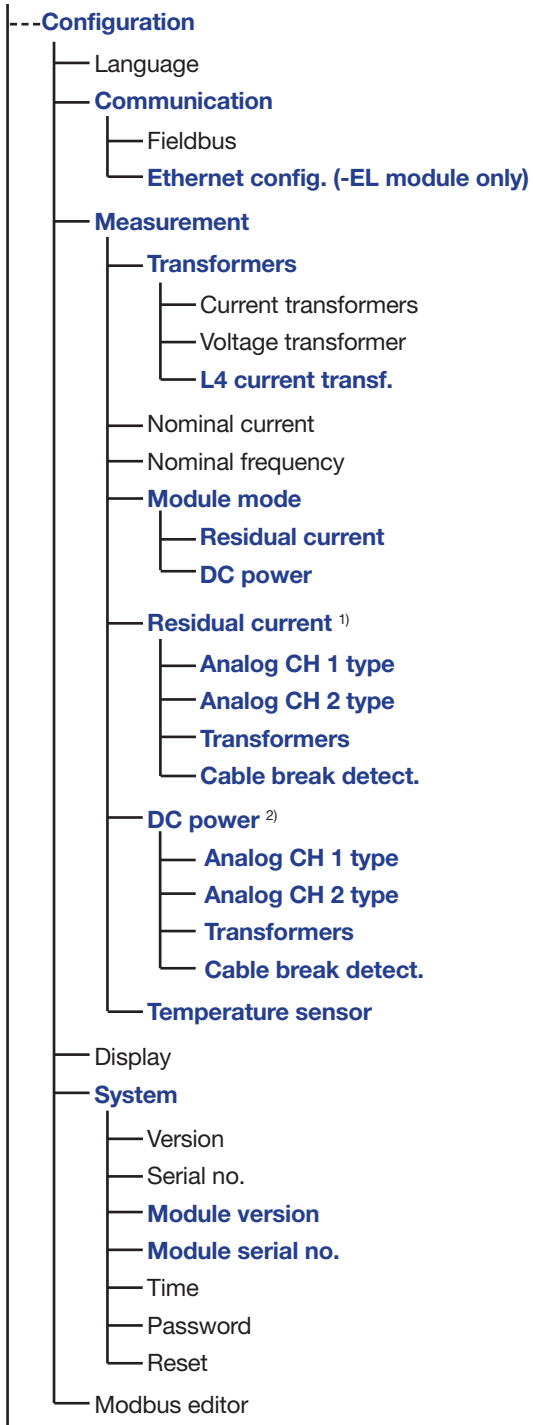

8. Communication

8.1 Basic device communication via the Ethernet interface (module 96-PA-RCM-EL)

The basic device with module 96-PA-RCM-EL has six ways to allocate addresses for an Ethernet connection (TCP/IP):

1. Static

The user selects the IP address, netmask and gateway on the device. Use this mode for simple networks with no DHCP server.

2. BOOTP

Automatically integrates your device in an existing network. BOOTP is an older protocol and has a smaller range of functions than DHCP.

3. DHCP

On start-up, the device is automatically given an IP address, netmask and gateway from the DHCP server.

4. Static gratuitous ARP

The user selects the IP address, netmask and gateway on the device. The device automatically logs into the network with IP and MAC address.

5. BOOTP ARP Probe

Simplified protocol for the automatic assignment of IP addresses to the MAC addresses. The device automatically logs into the network with IP and MAC address.

6. DHCP ARP Probe

Protocol for the automatic assignment of IP addresses to the MAC addresses. The device automatically logs into the network with IP and MAC address.

i INFORMATION

- The standard factory setting of the basic device with module 96-PA-RCM-EL is “dynamic assignment of IP address” (DHCP mode).
- Consult your network administrator for the Ethernet settings for your device.

8.1.1 Configuring Ethernet settings on the basic device

Configure the Ethernet settings or obtain details from the window *Communication > Ethernet (TCP/IP)*:

- Press button 1 (*Menu*) until the menu is open.
- Use buttons 3/4 (“▼”/“▲”) to select the menu item *Configuration* and confirm with button 6 *Enter*.
- In the *Configuration* window, use button 3 or 4 to select the item *Communication* and confirm with button 6.
- In the *Communication* window, use button 3 or 4 to select the item *Ethernet Config* and confirm with button 6.
- The window *Communication* appears with the Ethernet settings:

Communication	
Ethernet (TCP/IP)	
IP configuration	Static
Adress	192.168. 3.225
Netmask	255.255.255. 0
Gateway	192.168. 3. 4
RS485 Modus	Modbus gateway
Timeout	4500 ms
Esc	▼ ▲ Enter
1	2 3 4 5 6

Fig. Communication window > Ethernet configuration

- Configure the Ethernet (TCP/IP) settings as specified by the network administrator. Information on basic operation can be found in section „7. Operation and button functions of the basic device with module“ on page 37.

8.1.2 Configuring Ethernet settings via the GridVis® software

In the GridVis® software, you configure the Ethernet settings in the configuration window under *System*.

- In the symbol image of the rear side of the device, click on the *Ethernet* connection.
- Check the settings or adjust them according to the specifications of your network administrator.

i INFORMATION

For more information, please refer to the GridVis online help or wiki.janitza.com.

8.1.3 Configuring firewall settings via the GridVis® software

With the firewall (from firmware 2.18), you can block individual ports of the measurement device via the GridVis® software if this is desired for cyber security reasons. In the factory setting, all ports are open (firewall inactive).

i INFORMATION

By blocking the incorrect ports, you can unintentionally block any access to the device. If e.g. **Modbus TCP/IP** is blocked, access to measurement devices connected via Ethernet is no longer possible.

Follow the instructions of your network administrator for the correct settings!



Fig. Ethernet configuration via the GridVis® software, Ethernet interface selected

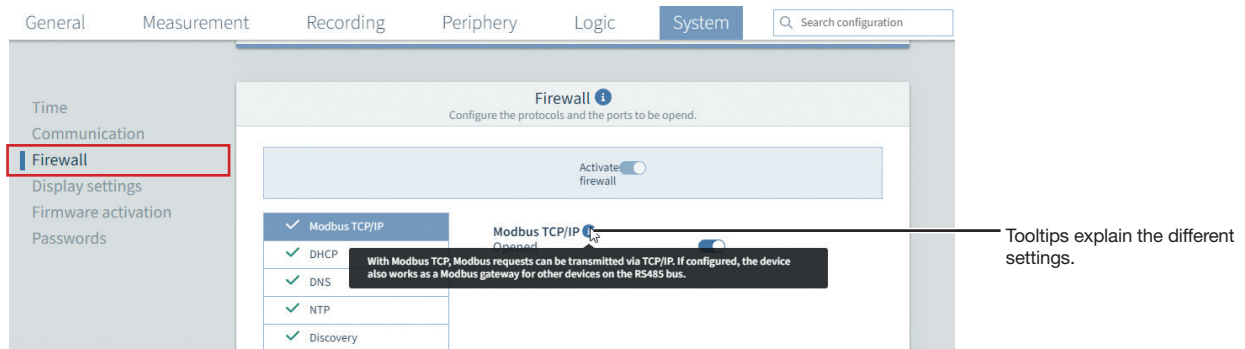

Fig. Firewall configuration via the GridVis® software

Tooltips explain the different settings.

8.4 Module-relevant alarms

When there is an alarm, the following warning alert appears:

Module communication error 17:56				
	Voltage	Current	Power	PF1
L1	0V	0.000A	0.00kW	< 1.00
L2	0V	0.000A	0.00kW	< 1.00
L3	0V	0.000A	0.00kW	< 1.00
L1..L3	50.00Hz	0.000A	0.00kW	< 1.00
Active energy		Reactive energy ind.		
L1..L3	0.0kWh		0.0kvarh	
Menu				Alarms
1	2	3	4	5
6				

Fig. Example "Basic device warning message in case of disturbed communication to the module".

When there is an alarm, the title bar of your device display is shown in *red* with the time indicated. It is also possible to activate blinking of the display when there is an alarm using the Modbus editor or the GridVis® software (see table below).

Pressing function button 5 displays a list of all alarms that have occurred, regardless of from which menu window it is pressed. In the alarm list, alarms can be selected and deleted.

Once all alarms have been deleted, the device closes the alarm list and goes to the last menu window.

Module-relevant alarm list:

Alarm description	Display property
Warning limit value for RCM channel 1 exceeded	
Alarm limit value for RCM channel 1 exceeded	Display blinks
Warning limit value for RCM channel 2 exceeded	
Alarm limit value for RCM channel 2 exceeded	Display blinks
Overcurrent L4	
Cable break on RCM channel 1	
Cable break on RCM channel 2	
No module communication for the last 10 seconds	Display blinks

Tab. Alarm list with module-relevant alarms

ATTENTION

A disconnected or defective module disrupts the communication with the basic device and leads to a device fault.

If communication between the basic device to the module is lacking or faulty during operation, a warning signal will appear on the display of the basic device.

- **Disconnect your system (the basic device) from the power supply prior to mounting the module.**
- **Check the positioning of the RCM module. If necessary, apply slight pressure to press the module onto the basic device until it audibly snaps in.**
- **Check the display of your basic device (if the menu item *Residual current* is present, the basic device has recognized the module).**
- **If necessary, restart the basic device before reinstallation (cf. section „8.3 Restarting the basic device“ on page 42)!**
- **If the measures indicated here are unsuccessful, please contact our support team (www.janitza.com)!**
- **If there is discernible damage, send the device, component or module back to the manufacturer in compliance with proper transport conditions.**

INFORMATION

- Detailed information on alarms and warning alerts can be found in the user manual of your basic device.
- A Modbus address list can be found in the download area at www.janitza.com.

9. Module-relevant configuration

Configure the relevant parameters for the module in the **Measurement** window of your basic device with module. To do so, use the function buttons of the basic device to go to the **Measurement window**:

- Press button 1 (*Menu*) until the menu is open.
- Use buttons 3/4 (“▼”/“▲”) to select the menu item *Configuration* and confirm with button 6 *Enter*.
- In the *Configuration* window, use buttons 3/4 (“▼”/“▲”) to select the item *Measurement* and confirm with button 6 *Enter*.
- The *Measurement* window appears with the following **settings for the RCM module**:

- Transformer for the basic device (I1 to I3) and L4 current transformer (I4 - neutral conductor measurement).**
- Transformer for the module mode *Residual current* or *DC power*.**
- Temperature sensor.**

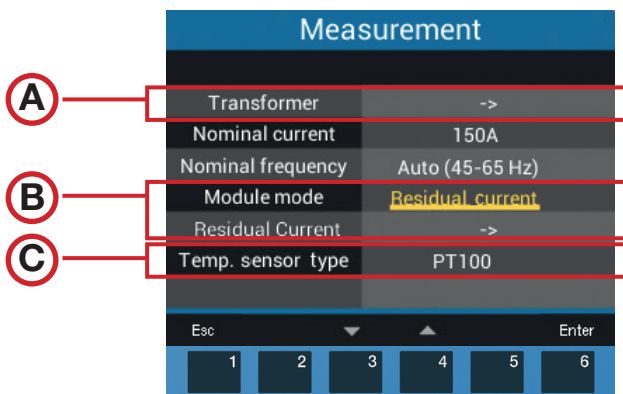

Fig. Window Measurement with the settings for the RCM module

A

9.1 L4 current transformer (I4 - measurement)

The **Transformer** item allows configuration of the current and voltage transformer ratios of the basic device as well as the current transformer ratios for the L4 current measurement (e.g. neutral conductor measurement).

1. Use buttons 3/4 (“▼”/“▲”) to select the item *Transformers* and confirm with button 6 *Enter*.
2. The Window for configuration of the L4 (I4) current transformer appears.
3. Select the item *L4 (I4) Current transformer* and confirm with button 6 *Enter*.
4. Use the function buttons of the basic device to configure the current transformer ratio as described in chap. „7. Operation and button functions of the basic device with module“ on page 37.

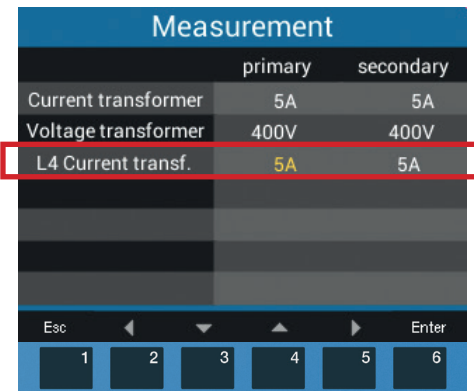

Fig. Measurement window with the L4 current transformer settings of the RCM module (default setting 5 / 5 A).

i INFORMATION

You can also set the module-relevant configuration in the GridVis® power grid monitoring software, see section „9.5 Module-relevant configuration with the GridVis® software“ on page 48.

B

9.2 Module mode

The **Module mode** item in the *Measurement* window is for switching the measurement modes:

1. **Residual current** or
2. **DC power**.

1. Module mode **Residual current**

- Use buttons 3/4 (“▼”/“▲”) to select the item *Module mode* and confirm with button 6 *Enter*.
- The measuring mode set is displayed in yellow (default setting *Residual current*).
- If necessary, use buttons 3/4 (“▼”/“▲”) to select the item *Residual current* and confirm with button 6 *Enter*.
- Afterwards, in the *Measurement* window, select the item *Residual current* and confirm with button 6, *Enter*.

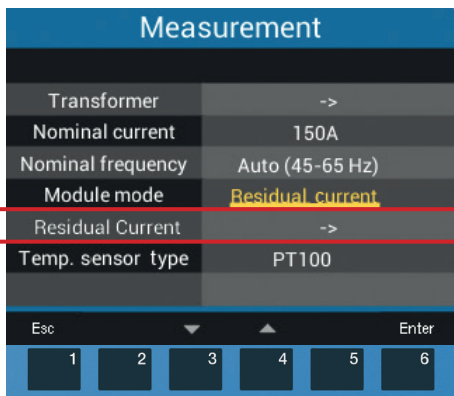

Fig. Window *Measurement* > *Module mode* “Residual current”

- The window *Display* “Residual current” appears with the parameters to be set:

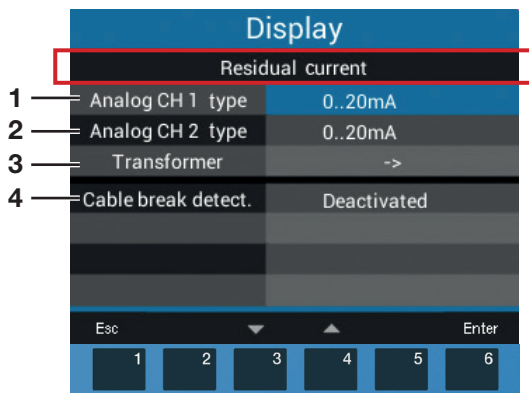

Fig. “Residual current” window display with the parameter settings for the residual current measuring mode.

No.	Residual current parameters	Settings
1	Analog CH 1 type, 15 terminal 29/30	Suitable transformer types: · AC (0 .. 30 mA _{rms}) · 0 .. 20 mA · 4 .. 20 mA
2	Analog CH 2 type, 16 terminal 31/32	Suitable transformer types: · AC (0 .. 30 mA _{rms}) · 0 .. 20 mA · 4 .. 20 mA
3	Transformer ratios	Current transformer: · CH 1 - prim. and sec. · CH 2 - prim. and sec.
4	Cable break detection	Configurable in the GridVis® software and in the Modbus editor (basic device).

Tab. Settings options in the **residual current** module mode

2. Module mode **DC power**

- Use buttons 3/4 (“▼”/“▲”) to select the item *Module mode* and confirm with button 6 *Enter*.
- The measuring mode set is displayed in yellow.
- Use buttons 3/4 (“▼”/“▲”) to select the item *DC power* and confirm with button 6 *Enter*.

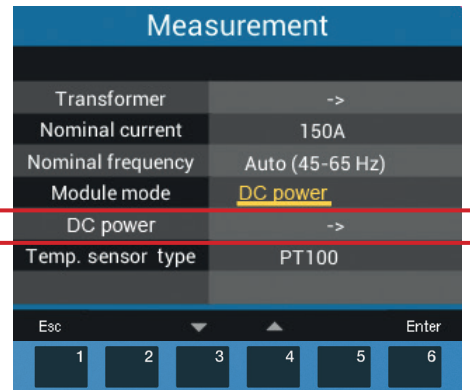

Fig. Window *Measurement* > *Module mode* “DC power”

- Afterwards, in the *Measurement* window, select the item *DC power*.
- To enter the *Display* window that contains the parameters to be set for the *DC power* measuring mode, confirm with button 6 *Enter*.

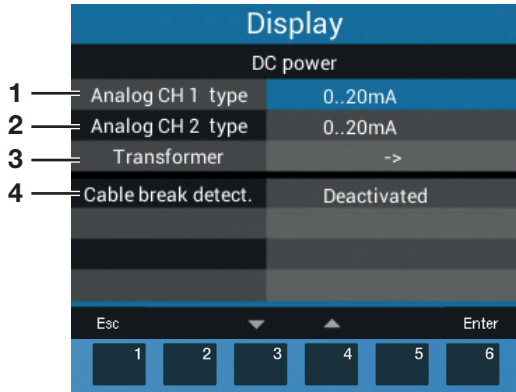

Fig. Display window with the DC power parameters

DC power measurement:
Transformer ratio for the input I6/U6

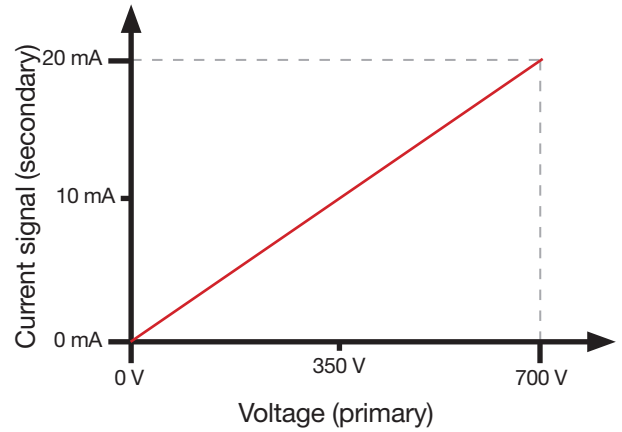

Fig. Graph "Transformer" analog input I6/U6

No.	DC power parameters	Settings
1	Analog CH 1 type, I5 terminal 29/30	Suitable transformer types: · 0 .. 20 mA · 4 .. 20 mA
2	Analog CH 2 type, I6/U6 ¹⁾ terminal 31/32	Suitable transformer types: · 0 .. 20 mA · 4 .. 20 mA
3	Transformer ratios ²⁾	Current transformer: · CH 1 - prim. and sec. · CH 2 - prim. and sec.
4	Cable break detection	Configurable in the GridVis [®] software and in the Modbus editor (basic device).

Tab. Setting options in DC power module mode

- 1) Power is determined from inputs I5 and I6 (U6) during the DC power measurement. A voltage (U6) is converted into a current signal by an active current transformer. The current signal responds proportionately to the value of the input voltage.
- 2) To set the transformer type 0..20 mA for CH2, configure a primary voltage and a proportional secondary current for the transformer ratio.

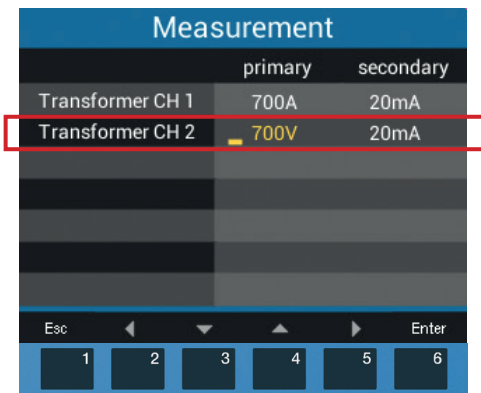

Fig. Measurement window with the configuration of the transformers for the DC power measurement mode.

C

9.3 Temperature sensor

1. In the *Measurement* window, select the item *Temperature sensor* and press button 6 *Enter*.
2. The temperature sensor item blinks.
3. Use buttons 3/4 (“▼”/“▲”) to select your temperature sensor from the list:
 - PT100 (default setting)
 - PT1000
 - KTY83
 - KTY84
4. Confirm using button 6 *Enter*.

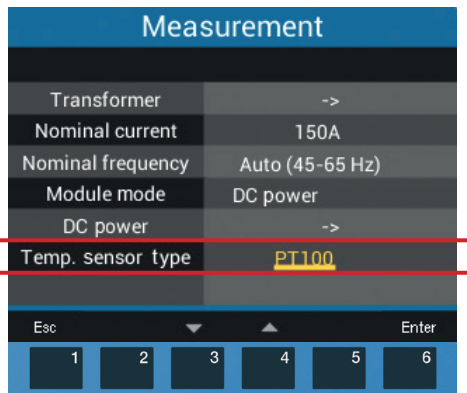

Fig. Window Measurement > Temperature sensor configuration

i INFORMATION

You can also configure the temperature sensor of your basic device conveniently via the PC connection to the GridVis® software (in scope of delivery).

9.4 Modbus editor

The basic device with module has a *Modbus editor* in the user interface. The *Modbus editor* item in the *Configuration* window provides access (read/write) to the Modbus addresses (*Menu > Configuration > Modbus editor*).

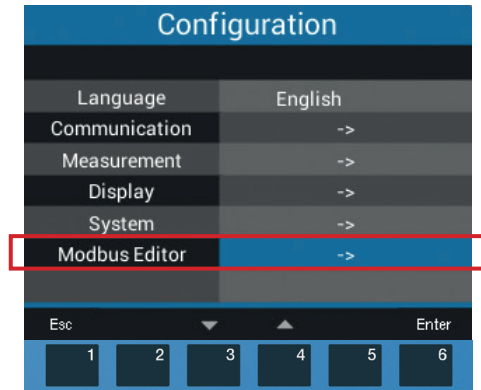

Fig. Configuration window with the Modbus Editor item

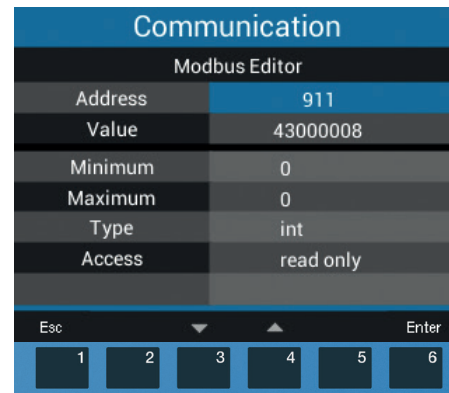

Fig. Configuration of the Modbus Editor

i INFORMATION

A Modbus address list for your basic device can be found in the download area at www.janitza.com.

Recommendation:

Use the GridVis® power grid monitoring software for all module-relevant settings!

9.5 Module-relevant configuration with the GridVis® software

The explanations of the measuring modes and the settings can be found in section „9. Module-relevant configuration“ on page 44.

- Select the device in the GridVis® software and click on *Configuration*.
- Click on the symbolized connections to display the corresponding settings.
- Mark the multifunctional channel L5 (terminals 29/30) or L6 (31/32) and select the measuring mode:
 - *Mode AC* or
 - *RCM 0..20 / 4..20 mA* or
 - *DC Power 0..20 / 4..20 mA*

- Be sure to select the same measuring mode for L6 as for L5.

i INFORMATION

For notes on setting the limit value calculation, see section „6.9 Residual current limit values“ on page 31.

Measuring modes *Mode AC* or *RCM 0..20 / 4..20 mA*

The screenshot displays the GridVis software interface for configuring a Multifunctional Channel L5. The 'Measurement mode' is set to 'Mode AC'. The 'Residual Current' menu is open, showing settings for Multifunctional Channel L5 and L6. The 'Residual current transformer' section shows a primary value of 700 and a secondary value of 1. The 'Residual current measurement' section shows a threshold calculation of 'Warning for residual current not active'.

Fig. Measuring mode Mode AC

In the measuring modes *Mode AC* and *RCM*, the *Residual Current* menu shows the settings for both channels L5 and L6.

DC power 0..20 / 4..20 mA measuring mode

The screenshot displays the configuration interface for the Janitza UMG 96-PQ-L device. The top section shows the 'Multifunctional Channel L5' configuration, where the 'Measurement mode' is set to 'DC power 0..20mA'. Below this, the 'Current Transformer' settings are shown, with 'Multifunctional Channel L5' selected. The 'Voltage Transformer' settings are also visible, with 'DC measurement L6' selected.

Multifunctional Channel L5

Channel Name: Multifunctional Channel L5

Measurement mode: DC power 0..20mA

Current Transformer

Specify the primary current to be converted to the secondary current.

Current Channel L1-L3
 Current Channel L4
 Multifunctional Channel L5

Primary: 10 A Secondary: 0.02 A

Voltage Transformer

Specify the primary voltage to be converted to the secondary voltage

Main measurement L1-L3

Primary: 400 V Secondary: 400 V

DC measurement L6

Primary: 230 V Secondary: 0.02 A

Fig. DC power measuring mode

In the *DC power* measuring mode, the *Current transformer* menu shows the settings for L5; the *Voltage transformer* menu shows the settings for L6.

10. Displays of the module

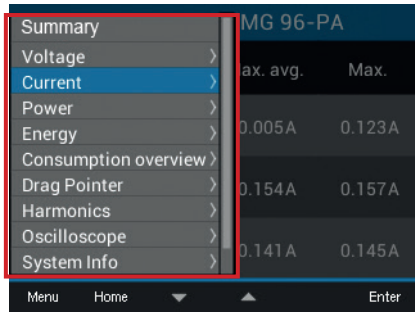

Opening a menu

- Press button 1 (*Menu*) to open the menu.
- Use buttons 3 (▼) and 4 (▲) to select the desired menu and confirm with button 6 (*Enter*).

The module expands the menus with the displays shown below.

10.1 Current menu – L4 current measurement

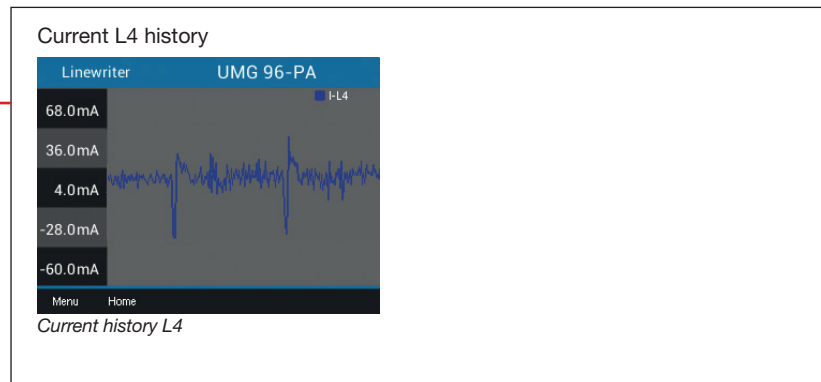
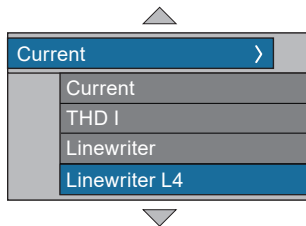

10.2 Harmonics menu

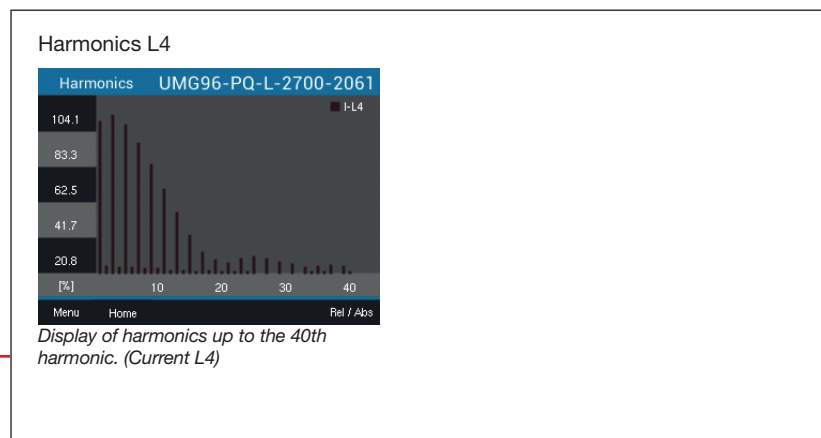
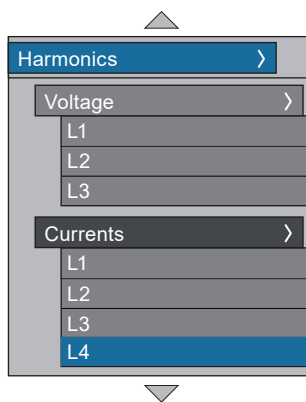

10.3 Residual current menu

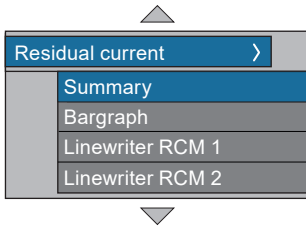

The menu is only available in the *Residual current* measuring mode.

Overview

Summary UMG 96-PA		
	RCM1	RCM2
Current	0.00 A	0.00 A
Current (max.)	1.83 A	5.85 A
Limit	10.3 A	0.00 A
Ref. Value	0.0 V	0.0

Measuring display for Current, Current (max.), Limit value and Reference value of RCM1 and RCM2

Bar chart

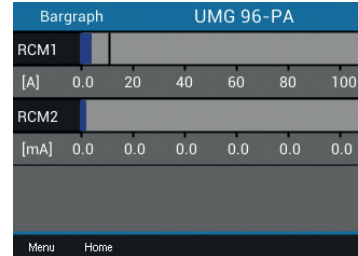

Bar chart of the I-RCM1 and I-RCM2 measured values

History, res. current 1

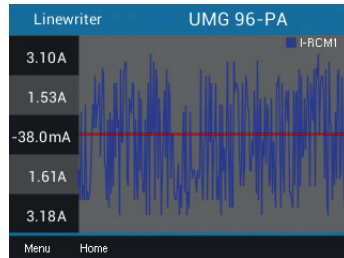

History of I-RCM1

History, res. current 2

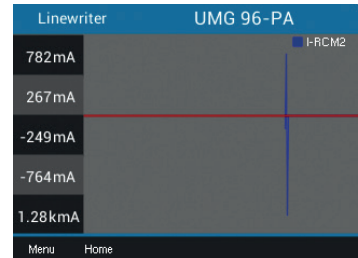

History of I-RCM2

10.4 DC power menu

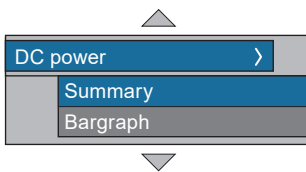

The menu is only available in the *DC power* measuring mode.

Overview

Summary UMG 96-PA			
	Value	Minimum	Maximum
Voltage	150 V	130 V	170 V
Current	3 A	2 A	4 A
Power	450 W	260 W	680 W
Energy	460 Wh		

Measuring display for Voltage, Current, Power and Energy (plus min and max. values)

Bar chart

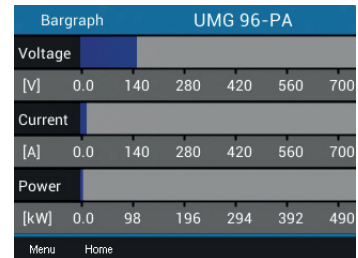

Display of voltage L1-L2, L2-L3, L1-L3 and their min. / max. values

i INFORMATION

Please note! Depending on the basic device, the measuring displays and menu entries shown above may differ from the actual device displays! Observe the usage information of your basic device.

10.5 System Info menu

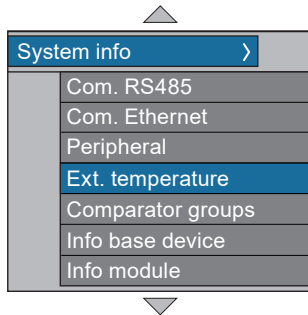

External temperature

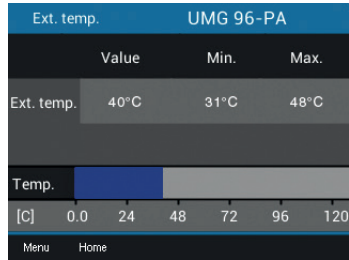

Bar chart and measuring display for the temperature (with min. and max. values)

Module info

The display shows 'Info module UMG96-PQ-L-2700-2061'. Below this is a table with the following data:

Type	96-RCM-EL
Serial no.	45021521
Version	2.18
MAC address	00:0e:6b:0d:4f:73

At the bottom are 'Menu' and 'Home' buttons.

Type, serial number and firmware version of the module
 MAC address of the Ethernet device (only for RCM-EL module)

10.6 Configuration menu – without password/after password entry

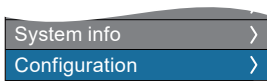

For information on the entries in the Configuration menu, see section „9. Module-relevant configuration“ on page 44.

Communication

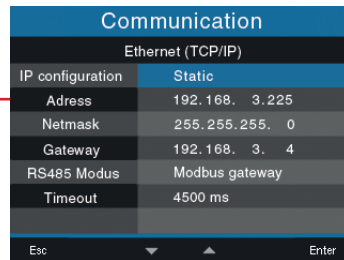
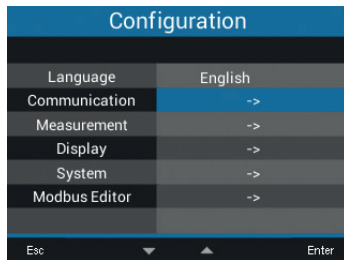

Network settings (only for RCM-EL module)

Measurement

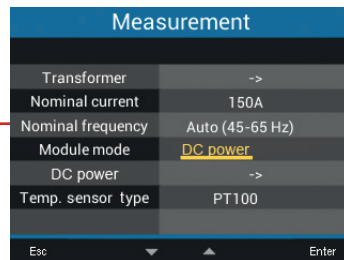
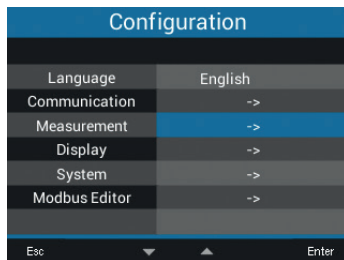

Settings especially of the transformers and the residual current / DC power module mode

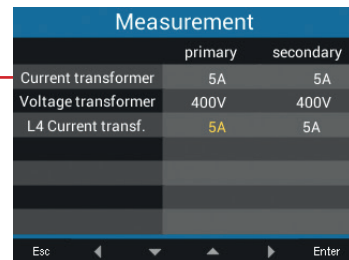

Setting the current transformer for I4 measurement

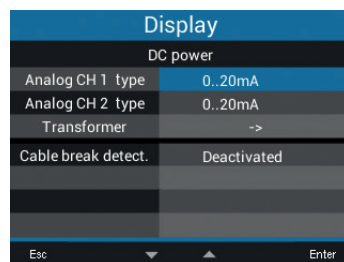

Settings for the residual current / DC power module mode

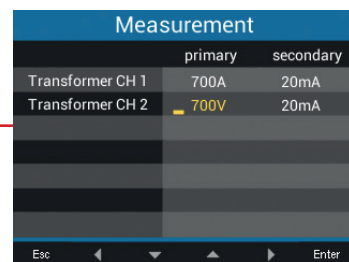

Settings of the current transformers for residual current / DC power

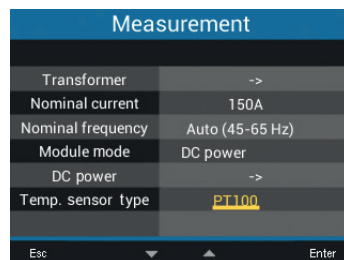

Temperature sensor type selection

11. Technical data for the module



11.1 Technical data

General	
Net weight of module (with attached plug-in connectors)	78 g (0.17 lbs)
Impact resistance	IK07 according to IEC 62262

Transport and storage	
The following specifications apply for devices transported and stored in the original packaging.	
Free fall	1 m (39.37 in)
Temperature	K55 -25° C (-13 °F) to +70° C (158 °F)
Relative air humidity (non-condensing)	0 to 90% RH

Environmental conditions during operation, see the usage information for your basic device.

Analog inputs	
Differential or current signals	2x
Temperature measurement	1x

Residual current input	
Nominal current	30 mA _{rms} 0...20 mA 4...20 mA
Measuring range	0 .. 30 mA _{rms}
Operating current	50 µA
Resolution	1 µA
Cable break detection (failure monitoring)	Can be activated
Crest factor	1.414 (relative to 30 mA)
Load	4 Ω
Overload for 1 s	1 A
Constant overloaded	200 mA
Measurement of residual currents	According to IEC/TR 60755 (2008-01):  Type A  Type B and B+ ¹⁾

¹⁾ B+ means extended frequency range, residual current transformers of the B+ type required.

Temperature measurement	
Update time	200 ms
Suitable thermal sensor	PT100, PT1000, KTY83, KTY84
Total burden (thermal sensor and lead)	max. 4 kΩ

Thermal sensor type	Temperature range	Resistance range	Measurement uncertainty
PT100	-99 °C (-146.2 °F) ... +500 °C (932 °F)	60 Ω ... 180 Ω	±1.5% rng
PT1000	-99 °C (-146.2 °F) ... +500 °C (932 °F)	600 Ω ... 1.8 kΩ	±1.5% rng
KTY83	-55 °C (-67 °F) ... +175 °C (347 °F)	500 Ω ... 2.6 kΩ	±1.5% rng
KTY84	-40 °C (-40 °F) ... +300 °C (572 °F)	350 Ω ... 2.6 kΩ	±1.5% rng

Current measurement I4*	
Nominal current	5 A
Measuring range	0.005 .. 6 A _{rms}
Crest factor	2 (relative to 6 A _{rms})
Overvoltage category	300 V CAT II
Power consumption	approx. 0.2 VA (Ri = 5 mΩ)
Sampling frequency	8.33 kHz
Resolution	16 bit
Rated surge voltage	2.5 kV
Overload for 1 s	60 A (sinusoidal)

* Exception: The specifications for I4 current measurement do not apply in combination with the UMG 96-PQ-LP as the basic device. As this device is equipped with four current measurement inputs, the I4 current measurement is carried out on the UMG 96-PQ-L-LP. In this case, the I4 current measurement input of the RCM module cannot be used and the specifications marked with * do not apply.

Ethernet interface (only module 96-PA-RCM-EL)		
Connection	RJ45	
Functions	Modbus gateway	
Protocols	ARP, IPv4, ICMP (ping)	
	TCP, UDP	Port: Application specific
	Modbus TCP	Port: 502
	Modbus UDP	Port: 502
	DHCP/BootP	Port: 67/68 (UDP)
	DNS server	Port: 53 (UDP)
	NTP server	Port: 123 (UDP)

Terminal connection capacity – Analog inputs (residual current, current signals, temperature)	
Connectible conductors. Connect one conductor per terminal position!	
Single core, multi-core, fine-stranded	0.2 - 1.5 mm ² , AWG 28-16
Wire ferrules (non-insulated)	0.2 - 1.5 mm ² , AWG 26-16
Wire ferrules (insulated)	0.2 - 1.5 mm ² , AWG 26-16
Tightening torque	0.2 - 0.25 Nm (1.77 - 2.21 lbf in)
Strip length	7 mm (0.2756 in)

Terminal connection capacity (current measurement I4*)	
Connectible conductors. Connect one conductor per terminal position!	
Single core, multi-core, fine-stranded	0.2 - 4 mm ² , AWG 28-12
Wire ferrules (non-insulated)	0.2 - 2.5 mm ² , AWG 26-14
Wire ferrules (insulated)	0.2 - 2.5 mm ² , AWG 26-14
Tightening torque	0.4 - 0.5 Nm (3.54 - 4.43 lbf in)
Strip length	7 mm (0.2756 in)

Cable lengths for analog input, residual current input, temperature measurement input, current measurement input I4*	
Up to 30 m (32.81 yd)	Unshielded
Greater than 30 m (32.81 yd)	Shielded

Potential isolation and electrical safety of the temperature measurement input
The temperature measurement input has: <ul style="list-style-type: none"> · Double insulation relative to the current measurement inputs, voltage measurement inputs and the supply voltage. · No insulation relative to the residual current input (RCM). · A functional isolation relative to the Ethernet interface.
The external temperature sensor must have double insulation against system parts with hazardous contact voltage (according to IEC 61010-1:2010).

11.2 Performance characteristics of functions

Function	Symbol	Accuracy class	Measuring range	Display range
Neutral conductor current I ₄ , measured*	I _N	1 (IEC61557-12)	0 .. 6 A _{rms}	0 A .. 999 kA
Neutral conductor current I ₄ , calculated*	I _{Nc}	1.0 (IEC61557-12)	0.03 .. 25 A	0.03 A .. 999 kA
Residual currents I ₅ , I ₆	I _{Diff}	1 (IEC61557-12)	0 .. 30 mA _{rms}	0 A .. 999 kA
Temperature	T	-	See temperature sensor types	0°C ... +100°C (32°F ... 212°F)

Table of module-relevant "Performance characteristics of functions".

- * Exception: The specifications for I₄ current measurement do not apply in combination with the UMG 96-PQ-LP as the basic device. As this device is equipped with four current measurement inputs, the I₄ current measurement is carried out on the UMG 96-PQ-L-LP. In this case, the I₄ current measurement input of the RCM module cannot be used and the specifications marked with * do not apply.

12. Dimensional drawings and views

12.1 Dimensional drawings

- All specifications in mm (in).
- The figures show the module 96-PA-RCM-EL and serve the purpose of illustration.
- The views shown are not true to scale.

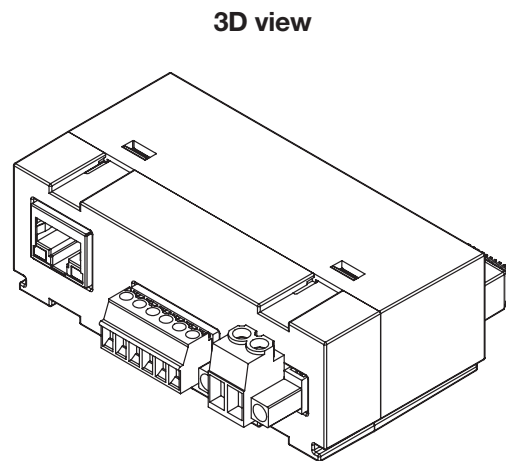
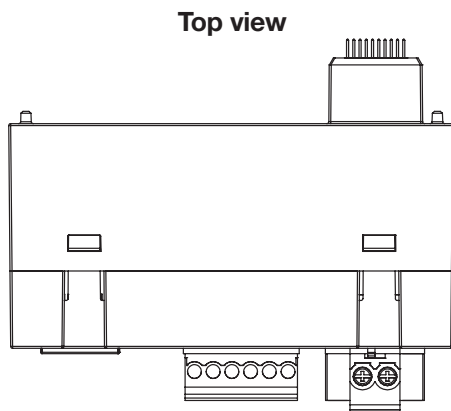
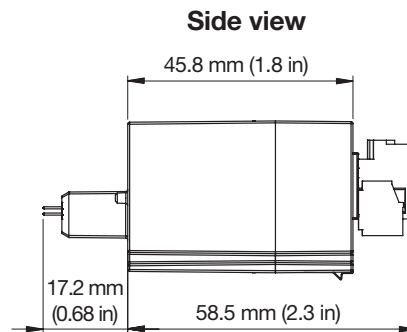
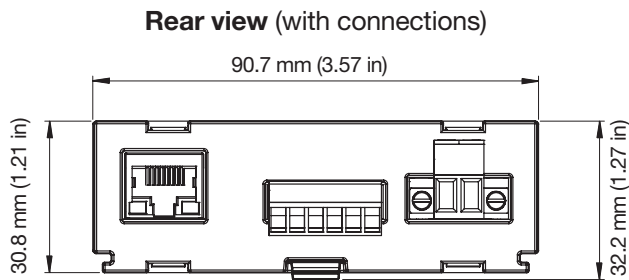

12.2 3D views of basic device with module

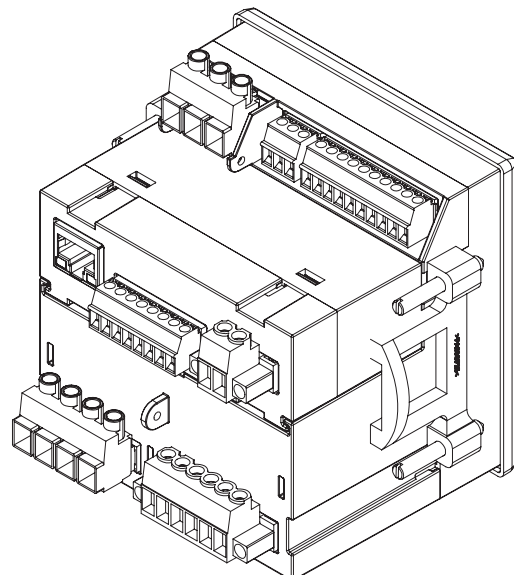
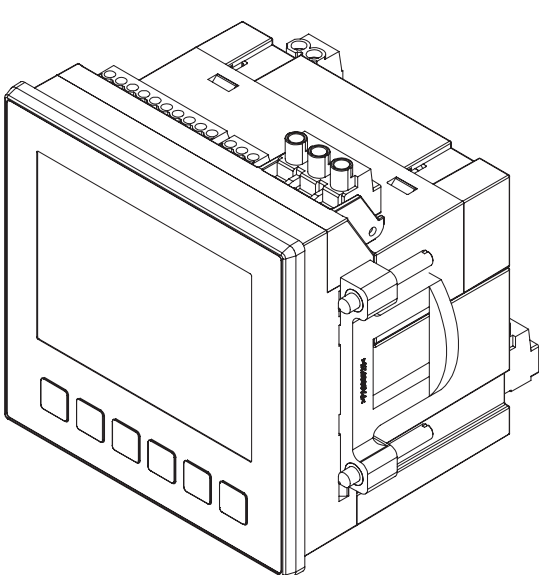

13. Dismounting

Dismounting module 96-PA-RCM or 96-PA-RCM-EL:

1. Disconnect the system (basic device) from the power supply!
2. Unlock your module by carefully lifting the snap-in locking device (fingernail or screwdriver if necessary) and pull it out of the slot.

ATTENTION

Handling your module too roughly may cause damage to the module and result in material damage!

The snap-in locking device can be damaged or broken off when unlocking the module.

- **Lift the snap-in locking device cautiously using slight pressure! Preferably use your fingernail (or a screwdriver, if necessary) to do so.**

ATTENTION

Dismounting or disconnecting the module while it is communicating with the basic device will result in a device fault!

In case of missing or disturbed communication of the basic device to the module during operation, a warning message appears on the display of the basic device (cf. section „8.4 Module-relevant alarms“ on page 43

- Disconnect your system (the basic device) from the power supply prior to dismounting or disconnecting the module!
- If necessary, restart the basic device before reinstallation (cf. section „8.3 Restarting the basic device“ on page 42)!

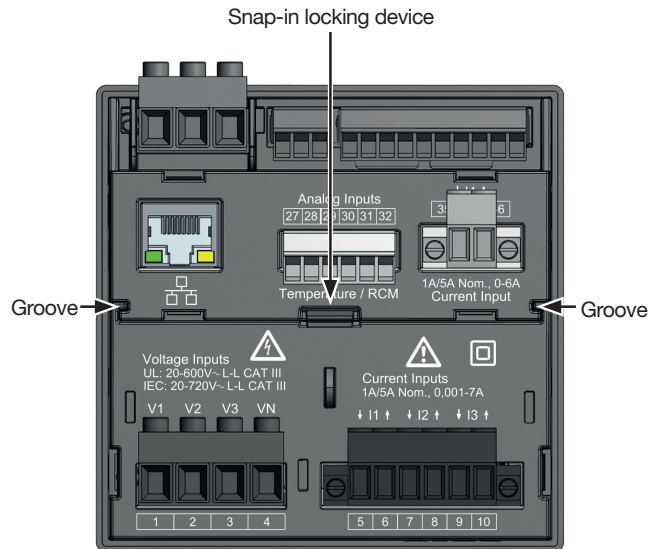

Fig. Rear side of the basic device with module, snap-in locking device and groove

14. Service and maintenance

Prior to outbound delivery, your device (component/module) is subjected to various safety tests and is marked with a seal. If the device (component/module) is opened, the safety tests must be repeated. The warranty is only valid for unopened devices (components/modules).

14.1 Repairs and calibration

Repairs and calibration can only be carried out by the manufacturer.

14.2 Service

If questions arise which are not described in this user manual, please contact the manufacturer. To answer your questions, it is essential that you provide the following information:

- Device designation (see rating plate).
- Serial number (see rating plate).
- Hardware version (see system display).
- Software release (see system display).
- Measured voltage and supply voltage.
- An exact error description.

14.3 Device adjustment

Devices (components/modules) are adjusted by the manufacturer prior to outbound delivery. No readjustment is required when the environmental conditions are complied with.

14.4 Calibration interval

Recalibrate your device about every 5 years. We recommend calibration by the manufacturer or an accredited laboratory!

14.5 Firmware update

For a firmware update, connect the basic device and module to a PC with the GridVis® software installed:

- Open the Firmware Update Assistant in the GridVis® software by clicking "Update device" in the "Extras" menu.
- Select a corresponding update file and carry out the update.

i INFORMATION

This user manual describes the module and provides information on the operation of the module via the basic device.

In addition to this user manual, refer to the usage information of your basic device, such as:

- User manual
- Installation manual
- "GridVis® Software" Quick Guide
- Safety information

Moreover, the GridVis® software has an "online help" feature.

14.6 Procedure in the event of a malfunction

ATTENTION

An error in the communication with the basic device leads to a device fault!

If communication between the basic device to the module is lacking or faulty during operation, a warning signal will appear on the display of the basic device.

- Disconnect the basic device (system) from the power supply prior to dismounting or disconnecting the module!
- If necessary, restart the basic device before reinstallation (see section „8.3 Restarting the basic device“ on page 42)!
- **Also take note of the section "Procedure in the event of a malfunction" in the usage information of your basic device.**
- **If the measures indicated here are unsuccessful, please contact our support team (www.janitza.com)!**
- **If there is discernible damage, send the device, component or module back to the manufacturer in compliance with proper transport conditions.**

14.7 Resetting the module to the standard factory settings

"Reset to standard factory settings" can be carried out for the module via your basic device. A description of this can be found in the user manual of your basic device.

Janitza[®]

Janitza electronics GmbH
Vor dem Polstück 6 | 35633 Lahnau
Germany

Tel.: +49 6441 - 9642-0
info@janitza.com | www.janitza.com