



Your Advantages

- For mobile generator sets according to DIN VDE 0100-551
- Preventive fire and system protection
- Detection of symmetric and asymmetric insulation faults
- Universal application in non-earthed AC, DC, AC/DC networks up to max. 300 V
- Easy adjustment of response values and setting parameter via rotational switch
- Suitable for large leakage capacitances up to 30 μF
- Monitoring also with voltage-free mains
- Measuring circuit L(+)/L(-) with broken wire detection (can be switched off)
- Protective conductor PE1/PE2 with broken wire detection (can't be switched off)
- No additional coupling device required

Features

- Insulation monitoring according to IEC/EN 61557-8
- 2 separate adjustable response thresholds (using e.g. for pre-Alarm and Alarm)
- Setting range of 1st response value (Pre-Alarm): 20 k Ω ... 1 M Ω
- Setting range of 2nd response value (Alarm): 10 k Ω ... 250 k Ω
- 2 changeover contacts für insulation failures-Pre-Alarm and -Alarm
- Energized or de-energized on trip can be selected for indicator relay
- LED for status indication
- Automatic and manual device self-test
- Alarm storage selectable
- Protection against manipulation by sealable transparent cover
- External control input for combined Test-/Reset-button
- 3 wide voltage input for auxiliary voltage
- Width 52.5 mm

Product Description

The insulation monitor RN 5897/300 of the VARIMETER IMD family is a solution for optimal insulation monitoring of modern IT systems. The device can be used in the most flexible way for AC, DC and AC/DC systems. The adjustment of the setting values is simple and user friendly done on 3 rotary switches on the front of the device. Via multicolor LED the device status is indicated easy to read. With a sealable transparent cover the device is protectet against manipulation.

Circuit Diagram

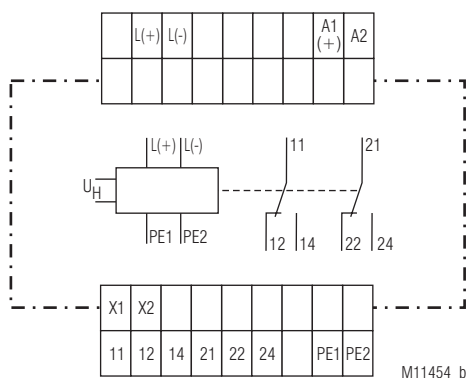

Approvals and Markings



Applications

- Insulation monitoring of:
- Non-earthed AC, DC, AC/DC networks
 - UPS systems
 - Networks with frequency inverters
 - Battery networks
 - Networks with direct current drives
 - Hybrid and battery-powered vehicles
 - Mobile generator sets

Connection Terminals

Terminal designation	Signal description
A1(+), A2	Auxiliary voltage AC or DC
L(+), L(-)	Connection for measuring circuit
PE1, PE2	Connection for protective conductor
X1, X2	Control input (combined external Test- and Reset-input)
11, 12, 14	Alarm signal relay K1 (1 changeover contact)
21, 22, 24	Prewarning signal relay K2 (1 changeover contact)

Function

The device is supplied with DC auxiliary voltage via terminals A1(+) / A2. Switching on the auxiliary voltage (Power-On) is followed by an internal self-test for 12 sec (see „Device test functions“). The test process is visible in the status LED. After this, measurement of the insulation resistance in the measuring circuits begins and the the colour of the status LED changes to green.

Measuring circuit

(Insulation measurement between terminals L(+) / L(-) and PE1/PE2)

The terminals L(+) and L(-) are connected directly to the voltage system to be monitored. A broken wire detection creates a fault signal if there is no low-ohmic connection between both terminals.

The type of network (AC, DC, 3NAC) has to be selected.

Also the terminals PE1 and PE2 have to be connected with 2 separate wires to the protective earth. An interruption of a wire also causes a fault signal (see section "Behavior on faulty connection"). The monitoring of the PE connection cannot be de-activated.

To measure the insulation resistance an active measuring voltage with changing polarity is connected between L(+)/L(-) and PE1/PE2.

At the end of a measuring cycle the actual insulation resistance is produced and indicated. The relays for alarm K1 and pre-alarm K2 switch when dropping under the adjusted response values. In addition the LED changes to orange color on pre-alarm or to red color on alarm.

Manual reset of fault message

The rotary switch "UN" is divided in 2 sections. So additional to the type of voltage system also manual or autoreset can be selected. (Alarm storing: manual reset, no alarm storing: auto reset).

If manual reset is activated the insulation fault signals of the measuring circuit are stored when dropping under the adjusted response values also if the insulation resistance goes back to healthy state. Pressing the „Reset“ button on the front side for 2 s, the alarm signal are reset if the actual insulation resistance is in healthy state.

Indicator relay for insulation fault signal

For the indicator relays K1 (contacts 11-12-14, for alarm) and K2 (contacts 21-22-24, for pre-alarm) the function energized on trip or de-energized on trip can be set via pre-alarm rotational switch "R_{pA}" when the insulation resistance drops below the adjusted response value.

Broken wire detection

As described in section "Measuring circuit", the measuring circuits L(+)/L(-) and the protective conductors PE1/PE2 are constantly monitored for wire breaks – not only at Power-On or a manual or occasional automatic test. The response time for monitoring PE1/PE2 is only a few seconds. The response time for monitoring L(+)/L(-) can be up to approximately 2 minutes. Broken wire detection between L(+) and L(-) is performed via coupled alternating voltage. This alternating voltage is short-circuited if the terminals are connected to the connected mains at low-resistance. The device detects that the mains to be monitored is properly connected.

Since this broken wire detection is carried out with alternating voltage, large capacitances should be avoided between L(+) and L(-), since the capacitive reactance of these capacitances also short-circuits this alternating voltage. The device would no longer detect a connection fault on L(+)/L(-).

Especially parallel lines should be avoided over larger distances.

If larger capacitances between L(+)/L(-) cannot be avoided or if the coupled alternating voltage interferes with the system, the broken wire detection can be de-activated using alarm rotary switch "R_A". Monitoring deactivated or continuous monitoring (every 2 minutes for 10 sec) are the possible options. If the broken wire detection on L(+)/L(-) is de-activated no AC voltage is injected.

The broken wire detection on PE1/PE2 cannot be de-activated.

Function

Device test functions

Principally, 2 different test functions are implemented: The "self-test" and the "expanded test":

The self-test of the device is performed automatically after Power-On and every full operating hours. It can also be triggered manually at any time by pressing the "Test" button at the device front for 2 sec.

With the self-test, contrary to the expanded test, the status of the Indicator relays is not affected; the sequence is as follows:

The self-test is indicated via LED with orange flash code 1. For approx. 5 s to negative test phase. Within these 5 s the internal measuring circuit is checked for failures. Then the measuring pulse is switched for approx. 5 s to positive test phase and more internal tests take place. If no failures turned up and had been recognized, the measurement continuous. The extended test procedure is started when during or at the end of the above described self-test (12 s) the test button is pressed again for 2 s.

The sequence is similar to the self-test (2 measuring phases of 5 s each) but in addition the output relays go in alarm stated. The LED shows orange flash code 2. The test phases of the extended test will be repeated continuously. The extended test can be finished after the first complete sequence (approx. 10 sec) by pressing the "reset" button for 2 seconds. The device starts the insulation monitoring again.

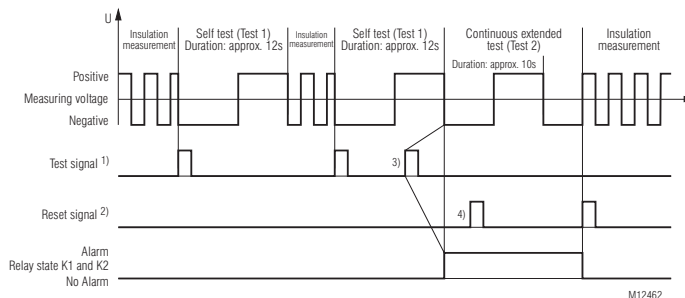

1) Test signal: Button Test > 2 s or X1/X2 < 3 s

2) Reset signal: Button Reset > 2 s or X1/X2 > 3 s

3) To initiate the extended test (Test 2) the test signal must be operated within the self test (Test 1) again.

4) The reset signal has here no function, as the first complete sequence of extended test (Test 2) is not finished.

Function

Behaviour with internal device faults

If internal device faults were detected during the test function, the LED flashes continuously red. The indicator relays K1 and K2 switch to the alarm state.

Behavior on faulty connection

When detecting broken wire on terminals L(+)/L(-), the measurement is disabled. The reaction time could be up to 2 min. The monitoring relays K1 and K2 go in alarm state, the LED indicates the red flash code 1. After removing the interruption the fault is automatically reset (max. reaction time up to 2 min) and the measurement of the insulation resistance is continued. Stored alarm values remain stored. An interruption of the protective earth connections PE1/PE2 causes the same reaction as interrupting the measuring circuit, only the LED indicate the red flash code 2.

External control input

To terminals X1/X2 an external combined Test-/Reset button can be connected. If the terminals X1/X2 are bridged for approx. 1 s the test mode is started. This has the same function as pressing the internal test button. When bridging X1/X2 for > 3 s, a stored alarm will be reset. This has the same function as pressing the internal reset button.

Programming/setting of parameters/set-up of the insulation monitor

All settings are done with 3 rotary switches on the front of the unit. To avoid unauthorized manipulation of the settings, all 3 switches are located behind a sealable transparent cover. The first rotary switch "R_A" sets the response value for alarm. In addition it is divided in 2 sections. If the setting position is in the first section the broken wire detection is permanent enabled, if the setting position is in the second section the broken wire detection is permanent disabled. The second rotary switch "R_{PA}" sets the response value for pre-alarm. In addition it is also divided in 2 sections. If the setting position is in the first section, the relay output function is de-energized on trip, if the setting position is in the second section, the relay output function is energized on trip.

The third rotary switch "UN" selects the type of network connection. It is also divided in 2 sections. If the setting position is in the first section, the unit is on auto reset, if the setting position is in the second section, the unit is on manual reset.

New settings are accepted without restart of the device.

Function Diagram

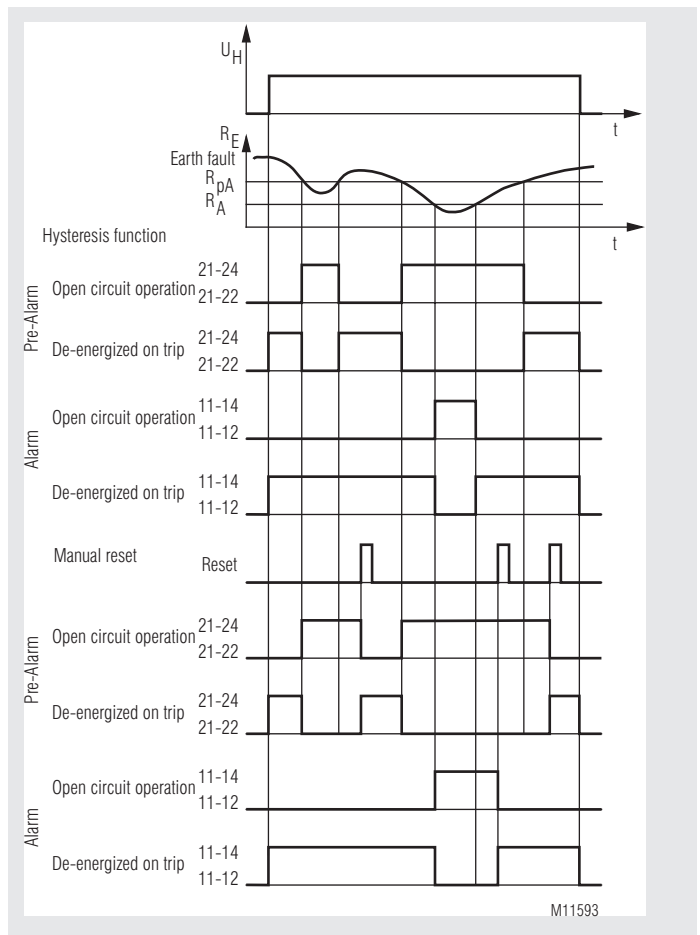

Flashing Codes Status LED

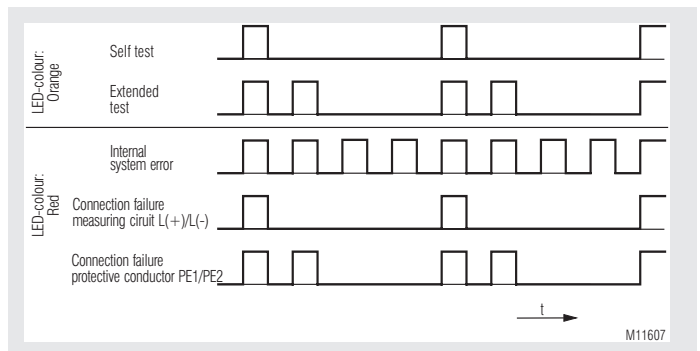

Indicators

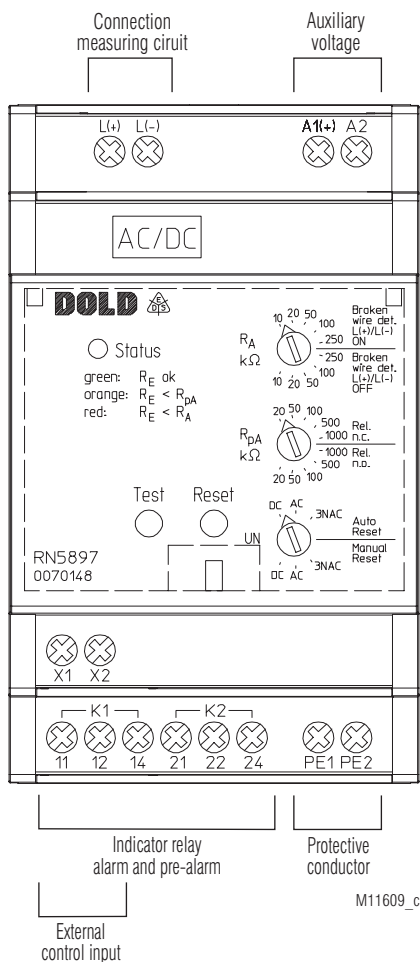

Indicators

The operational status of the device is indicated on a 3-colour LED:

Off:	No auxiliary voltage connected
Green:	Normal operation (Insulation resistance in healthy state)
Red:	Alarm (measured value below alarm response value)
Orange:	Warning (measured value below pre-alarm response value)
Orange flashing:	Test mode procedure (see flashing code diagramm)
Red flashing:	Failure code (see flashing code diagramm)

Flash code orange Status-LED	Description
1	Selftest (measuring circuit, measuring voltage, internal tests)
2	Advanced Test (additional control of indicator relays)

Error Indication

Flash code red Status-LED	Failure cause	Failure recovery
1	Broken wire detection on L(+)/L(-).	Check measuring circuit L(+) and L (-)
2	Broken wire detection on PE1/PE2.	Check protective earth connections PE1 and PE2
Continuously flashing	Internal failure detected in test mode	Press test button again or restart the unit by interrupting the auxiliary supply or via control input X1/X2. If the fault remains permanent, send device back to manufacturer for examination

Notes



Risk of electrocution!

Danger to life or risk of serious injuries.

- Disconnect the system and device from the power supply and ensure they remain disconnected during electrical installation.
- The terminals of the control input X1-X2 have no galvanic separation to the measuring circuit L(+) and L(-) and are electrically connected together, therefore they have to be controlled by volt free contacts or bridge. These contacts ore bridges must provide a sufficient separation depending on the mains voltage on L(+)-L(-).
- Please do not connect external voltage to terminals X1/X2. The control must only be made by bridging X1 and X2.



Attention!

- Before checking insulation and voltage, disconnect the monitoring device RN 5897 from the power source!
- In one voltage system only one insulation monitor can be used. This has to be observed when interconnecting two separate systems..
- Device terminals PE1 and PE2 must always be connected via separate lines to different terminal points of the protective-conductor system.
- The device must not be operated without PE1/PE2 connection!
- To ensure correct measurement of the insulation resistance, there must be a low-impedance connection ($\leq 10 \text{ k}\Omega$) or a low-impedance internal system resistance across the source or across the load between the measuring circuit connections L(+) and L(-).
- To ensure correct measurement of the insulation resistance, there must be a low-impedance connection ($\leq 10 \text{ k}\Omega$) or a low-impedance internal mains resistance across the source or across the load between the measuring circuit connections L(+) and L(-) (or L1(+) and L2(-) when using the ballast unit).



Attention!

- The main measuring circuit can be connected with its terminals L(+) and L(-) both to the DC and also AC side of a mixed network; it is done most practically where the primary incoming power supply takes place e.g. battery networks with connected inverters on the DC side, with Generators/ Transformers with connected Rectifiers or inverters on the AC-side. To monitor a 3NAC system the device can be connected single pole, (L(+)) and L(-) are bridged, to the neutral of the 3p4w system. The 3 phases have a low-ohmic (approx. 3 – 5 Ohm) connection via the transformer windings so also insulation failures of the not directly connected phases are detected. Via the rotational switch „UN“ the correct type of network needs to be selected (see „Connection Examples“).
- If a monitored AC system includes galvanically connected DC circuits (e.g. via a rectifier), an insulation failure on the DC side can only be detected correctly, when a current of min 10 mA can flow via the semiconductor connections.
- If a monitored DC system includes galvanically connected AC circuits (e.g. via an inverter), an insulation failure on the AC side can only be detected correctly, when a current of min 10 mA can flow via the semiconductor connections.

Technical Data		
Measuring circuit L(+)/L(-) to PE1/PE2		
Nominal voltage U_N:	AC / DC 0 ... 230 V	
Max. voltage range U_N:	AC / DC 0 ... 300 V	
Frequency range:	DC or 40 ... 1000 Hz	
Max. line capacitance:	30 μ F	
Internal resistance (AC / DC):	> 120 k Ω	
Measuring voltage:	Approx. \pm 90 V	
Max. measured current ($R_E = 0$):	< 0.80 mA	
Response inaccuracy:	\pm 15 % \pm 1.5 k Ω IEC 61557-8	
Response value hysteresis:	Approx. + 25 %; min. + 1 k Ω	
On delay		
at $C_E = 1 \mu$ F,		
R_E of ∞ to 0.5 * response value: \leq 1 s (at setting 3N AC)		
< 5 s (at setting AC, DC)		
Measuring time:		
at $C_E = 1 \dots 30 \mu$ F,		
R_E from ∞ to 1000 k Ω ,		
R_E from ∞ to 100 k Ω ,		
R_E from ∞ to 1 k Ω : See characteristics		
Response values:		
Pre-warning (R_{PA}):		
k Ω :	20 50 100 500 1000	
Alarm (R_A):		
k Ω :	10 20 50 100 250	
Each adjustable via rotational switches		
Response value broken wire detection L(+)/L(-): > Approx. 30 k Ω		
Response value broken wire detection PE1/PE2: > Approx. 0.5 k Ω		
Auxiliary voltage input A1(+)/A2		
Nom. Voltage	Voltage range	Frequency range
AC/DC 24 ... 60 V	AC 19 ... 68 V	45 ... 400 Hz; DC 48 % W*)
	DC 16 ... 96 V	W*) \leq 5 %
AC/DC 85 ... 230 V	AC 68 ... 276 V	45 ... 400 Hz; DC 48 % W*)
	DC 67 ... 300 V	W*) \leq 5 %
DC 12 ... 24 V	DC 9.6 ... 30 V	W*) \leq 5 %
*) W = Permitted residual ripple of auxiliary supply		
Nominal consumption:		
DC 24 V, 48 V:	Max. 3 W	
AC 230 V:	Max. 6.2 VA	
Control input X1/X2 for external combined test/reset button		
Current flow:	Approx. 3 mA	
No-load operation voltage X1 to X2: Approx. 12 V		
Permissible wire length:	< 50 m	
Activation time for test signal:	Approx. 1 s	
Activation time for reset signal:	> 3 s	
Outputs		
Indicator contact:	2 x 1 changeover contact for Alarm (K1) and Pre-Alarm (K2) energized or de-energized on trip (programmable)	
Thermal current I_{th}:	Max. 4 A (see also Temperature range Operation)	
Switching capacity		
to AC 15:		
NO contact:	5 A / AC 230 V	IEC/EN 60947-5-1
NC contact:	2 A / AC 230 V	IEC/EN 60947-5-1
To DC 13:	2 A / DC 24 V	IEC/EN 60947-5-1
Electrical life		
at 5 A, AC 230 V:	1 x 10 ⁵ switching cycles	
Short circuit strength		
max. fuse rating:	4 A gG / gL IEC/EN 60947-5-1	
Mechanical life:	50 x 10 ⁶ switching cycles	

Technical Data	
General Data	
Operating mode:	Continuous operation
Temperature range	
Operation:	
Auxiliary voltage	
DC 12 ... 24 V,	- 40 ... + 70 °C
AC/DC 24 ... 60 V:	- 40 ... + 70 °C
	At an altitude of > 2000 m the maximum permissible temperature reduces by 0.5 °C / 100 m
Auxiliary voltage	
AC/DC 85 ... 230 V:	- 40 ... + 60 °C
	- 40 ... + 70 °C
	(device mounted with min. 1 cm distance to adjacent devices or device with max. 2 x 0.5 A contact current)
	At an altitude of > 2000 m the maximum permissible temperature reduces by 0.5 °C / 100 m
	- 40 ... + 70 °C
Storage:	
Altitude, Clearance and creepage distances	
Rated insulation voltage:	300 V
Overvoltage category:	III (\leq 2000 m)
	II (> 2000 m up to \leq 4000 m)
Rated impuls voltage / pollution degree:	IEC 60664-1
Measuring circuit L(+)/L(-) to auxiliary voltage A1(+)/A2 and indicator relay contacts K1, K2:	\leq 2000 m > 2000 m up to \leq 4000 m
	6 kV / 2 4 kV / 2
Auxiliary voltage A1(+)/A2 to indicator relay contacts K1, K2:	\leq 2000 m > 2000 m up to \leq 4000 m
	6 kV / 2 4 kV / 2
Indicator relay contact K1 to indicator relay contacts K2:	\leq 2000 m > 2000 m up to \leq 4000 m
	4 kV / 2 2.5 kV / 2
Insulation test voltage	
Routine test:	AC 2.5 kV; 1 s
	AC 4 kV; 1 s
EMC	
Electrostatic discharge (ESD):	8 kV (air) IEC/EN 61000-4-2
HF irradiation:	
80 MHz ... 1 GHz:	20 V / m IEC/EN 61000-4-3
1 GHz ... 2.7 GHz:	10 V / m IEC/EN 61000-4-3
Fast transients:	2 kV IEC/EN 61000-4-4
Surge voltage	
between	
wires for power supply:	1 kV IEC/EN 61000-4-5
Between wire and ground:	2 kV IEC/EN 61000-4-5
HF-wire guided:	20 V IEC/EN 61000-4-6
Interference suppression:	Limit value classe B EN 55011
Degree of protection	
Housing:	IP 30 (not sealed) IEC/EN 60529
	IP 40 (sealed with seal wire 50/30) IEC/EN 60529
	The unit must be disconnected from the power supply before the seal is applied
Terminals:	IP 20 IEC/EN 60529
Housing:	Thermoplastic with V0 behaviour according to UL subject 94
Vibration resistance:	Amplitude 0.35 mm, Frequency 10 ... 55 Hz, IEC/EN 60068-2-6
	Frequency 2 ... 13.2 Hz, 13.2 ... 100 Hz, acceleration \pm 0.7 gn IEC/EN 60068-2-6
Shock resistance:	10 gn / 11 ms, 3 pulses IEC/EN 60068-2-27
Climate resistance:	40 / 070 / 04 IEC/EN 60068-1
Terminal designation:	EN 50005
Wire connection	DIN 46228-1/-2/-3/-4
Cross section:	0.5 ... 4 mm ² (AWG 20 - 10) solid or 0.5 ... 4 mm ² (AWG 20 - 10) stranded wire without ferrules 0.5 ... 2.5 mm ² (AWG 20 - 10) stranded wire with ferrules
Stripping length:	6.5 mm
Max. fixing torque:	0.5 Nm
Wire fixing:	Box terminal with cross recess screw
Mounting:	DIN rail IEC/EN 60715
Weight:	Approx. 200 g
Dimensions	
Width x height x depth:	52.2 x 90 x 71 mm

Classification to DIN EN 50155

Vibration and shock resistance: Category 1, Class B IEC/EN 61373
Service temperature classes: OT1, OT2 compliant
Protective coating of the PCB: No

UL-Data

Temperature range:
Operation: - 30 ... + 60 °C

Altitude: ≤ 2000 m

Switching capacity: Pilot duty C300, R300
5A 250Vac
2A 30Vdc

Wire connection: 60 °C / 75 °C copper conductors only
Torque 0.5 Nm

Test specification: ANSI/UL 60947-1, 5th Edition
ANSI/UL 60947-5-1, 3rd Edition
CAN/CSA-C22.2 No. 60947-1-13, 2nd Edition
CAN/CSA-C22.2 No. 60947-5-1-14, 1st Edition



Technical data that is not stated in the UL-Data, can be found in the technical data section.

CCC-Data

Switching capacity

to AC 15
NO contact: 3 A / AC 230 V
NC contact: 1 A / AC 230 V



Technical data that is not stated in the CCC-Data, can be found in the technical data section.

Standard Types

RN 5897.12/300/61	DC 12 ... 24 V
Article number:	0070147
• Auxiliary voltage:	DC 12 ... 24 V
RN 5897.12/300/61	AC/DC 24 ... 60 V
Article number:	0070148
• Auxiliary voltage:	AC/DC 24 ... 60 V
RN 5897.12/300/61	AC/DC 85 ... 230 V
Article number:	0070149
• Auxiliary voltage:	AC/DC 85 ... 230 V
• Outputs:	1 changeover contact for pre-warning 1 changeover contact for alarm
• Setting range pre-warning:	20 kΩ ... 1 MΩ
• Setting range alarm:	10 kΩ ... 250 kΩ
• Max. line capacitance:	30 μF
• Energized or de-energized on trip	
• Selection of type of network	
• Width:	52.5 mm

Ordering Example for variants

RN 5897 .12 /300 /61 AC/DC 24 ... 60 V 10 kΩ - 250 kΩ 20 kΩ - 1 MΩ

- Setting range Pre-warning
- Setting range alarm
- Auxiliary voltage
- UL approval
- Variant, if required
- Contacts
- Type

Accessories

Flush mounting kit

Order reference: KU 4087-150/0056598

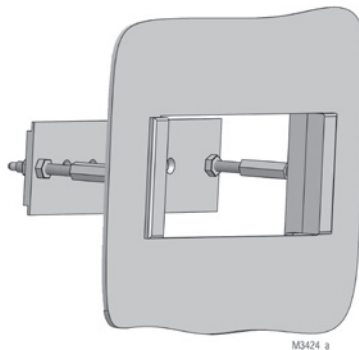

For universal use with:

- R-series devices of 17.5 to 105 mm width
- Easy mounting

Connection Examples

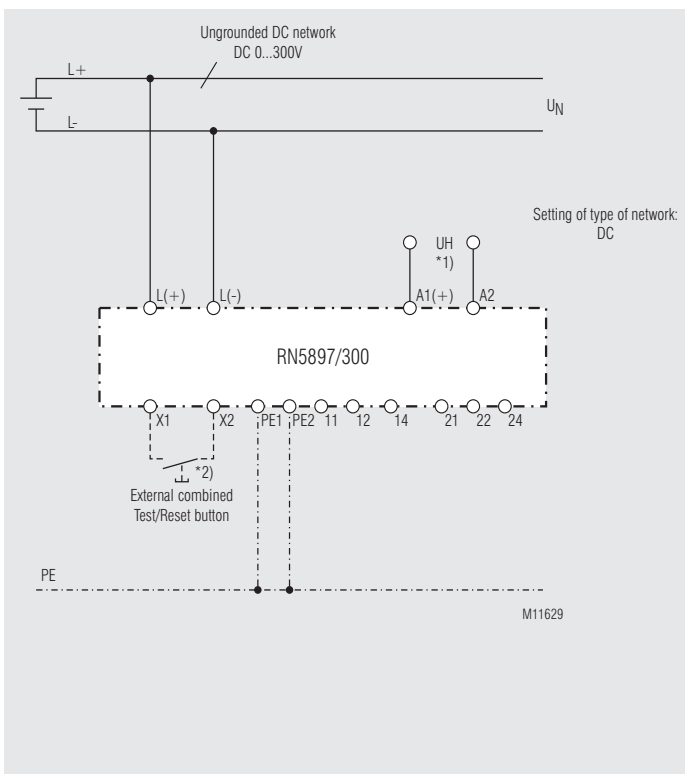
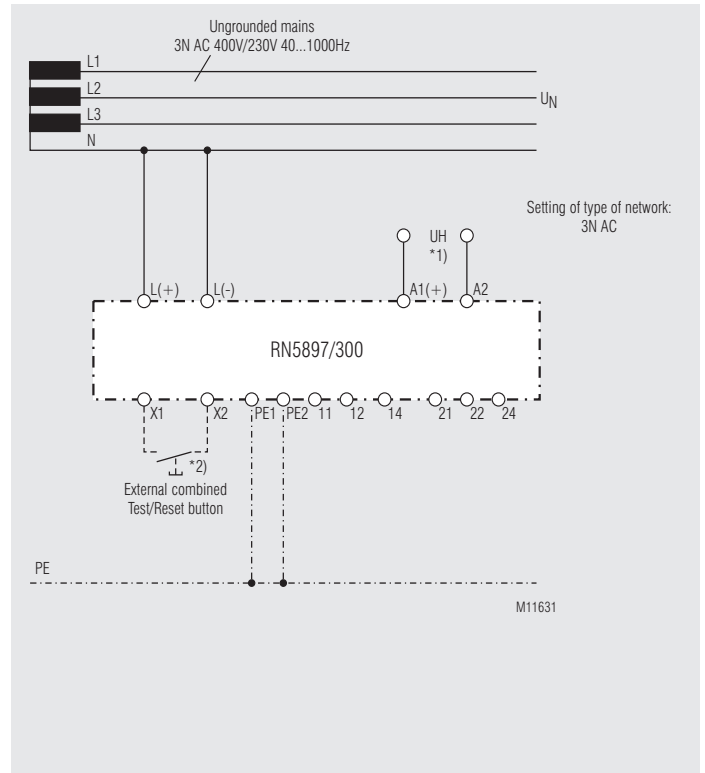
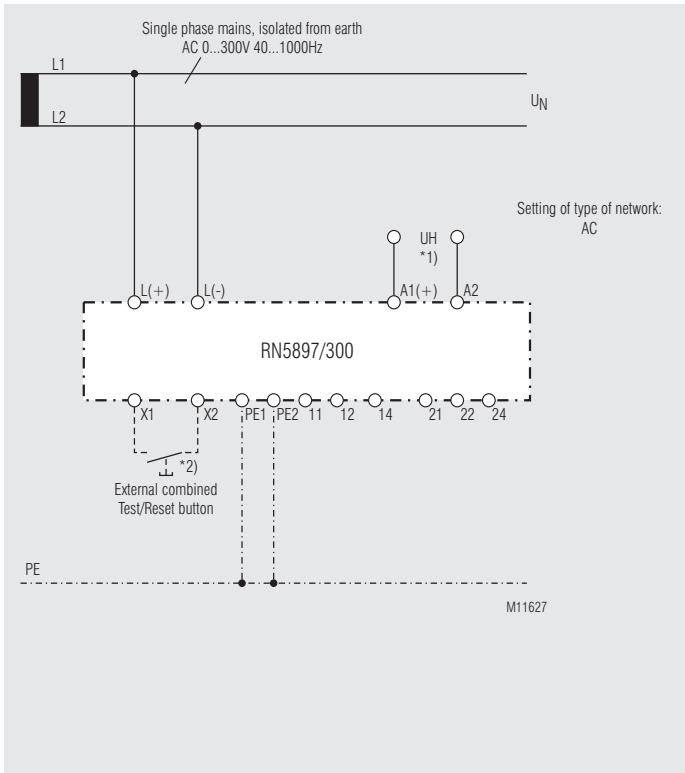

*1) Auxiliary voltage U_H (A1(+)/A2) can also be sourced from the monitored voltage system.
The voltage range of the auxiliary supply has to be taken into account.

*2) Control input X1/X2 for external combined Test-/Reset-button:

- Control approx. 1 s: Test function
- Control > 3 s: Reset function

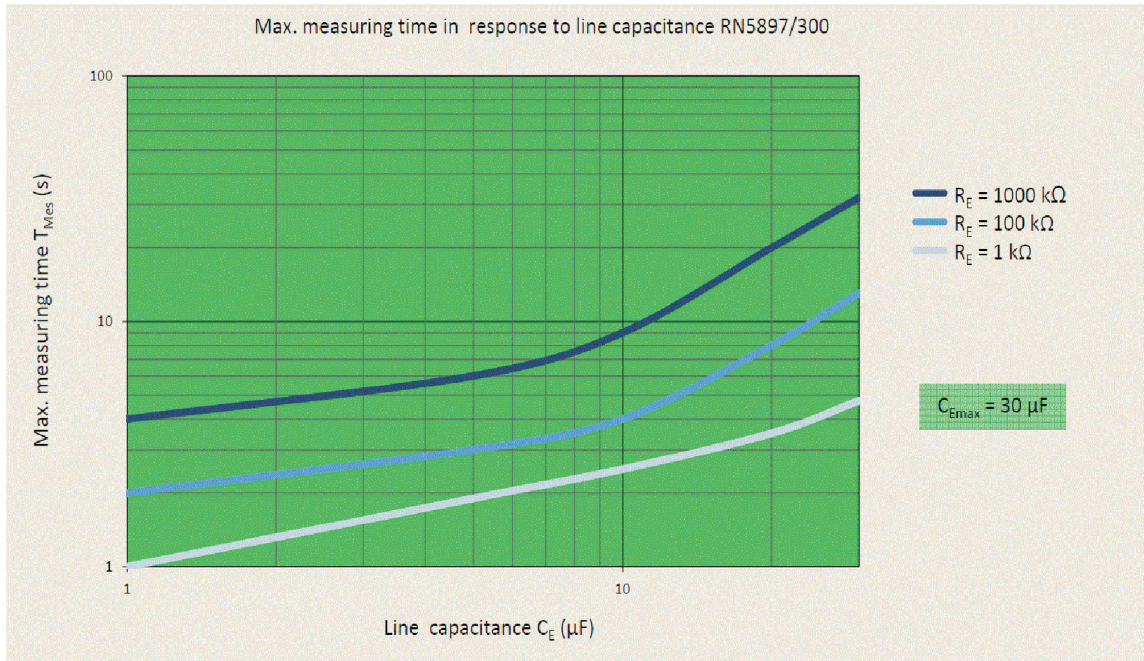

M11611