

# 800-CT24 current measuring module

Expansion module for basic devices of the 800 series

User manual and technical data

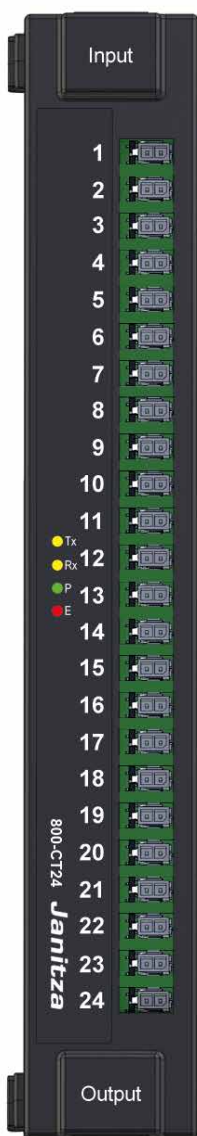



#### Suitable basic devices and number of module slots:

Suitable basic devices / Number of free slots	Slot assignment of an 800-CT24 module on the basic device
UMG 801 (from FW 1.5.0) / 10 slots	3 slots

Tab. Suitable basic devices

## 800-CT24 current measuring module

(Suitable for basic devices of the 800 series)

Doc. no.: 2.053.095.1.b

Date: 12/2023

The German version is the original edition of the documentation

## Subject to technical alterations.

The contents of our documentation have been compiled with great care and reflect the current state of the information available to us. Nonetheless, we wish to point out that updates of this document are not always possible at the same time as technical refinements are implemented in our products. Please see our website under [www.janitza.com](http://www.janitza.com) for the current version.

Please see our website under [www.janitza.com](http://www.janitza.com) for the current version.

## Information about the GridVis® software.

 Janipedia: [wiki.janitza.de](http://wiki.janitza.de)

 Tutorials: [youtube.com/@gridvis](https://youtube.com/@gridvis)

## Table of contents

<b>1. Information on the devices and the user manual</b>	<b>8</b>
1.1 Disclaimer	8
1.2 Copyright notice	8
1.3 Technical changes	8
1.4 About this user manual	8
1.5 Defective device/disposal	9
<b>2. Safety</b>	<b>10</b>
2.1 Display of warning notices and safety information	10
2.2 Hazard levels	10
2.3 Product safety	10
2.4 Hazards when handling the device, components and modules	11
2.5 Electrically qualified personnel	12
2.6 Warranty in the event of damage	12
2.7 Safety information for handling current transformers	12
<b>3. Product description</b>	<b>14</b>
3.1 800-CT24 current measuring module	14
3.2 Incoming goods inspection	15
3.3 Intended use	15
3.4 Overview of module functions	15
3.5 EU/UKCA Declaration of Conformity	16
3.6 FCC Declaration of Conformity	16
3.7 Protective device/transformer	16
3.8 Scope of delivery	16
3.9 Accessories	16
3.10 Operating concept	17
3.11 GridVis® network analysis and programming software	17
<b>4. Mounting</b>	<b>18</b>
4.1 Mounting the 800-CT24 module with 800-CON RJ45 transfer module	18
4.2 The 800-CT24 module in JanBus module topologies	20
4.2.1 Topology example: Combined module topology with 800-CT24 module	21
4.2.2 Topology example: 3 modules of the type 800-CT24	21
4.3 Checking module communication	22
4.4 System information on the module	22
4.5 Faulty module communication	23

5. Connections/controls.....	24
6. Module markings – rating plate.....	25
7. Installation.....	26
7.1 Current measurement with the module.....	26
7.2 Startup procedure/initialization.....	26
7.3 Connection diagram "Current measurement" for 1st 800-CT24 module.....	27
7.4 Module identification / Diagnostics on the basic device.....	28
7.4.1 Entry "Identify one module".....	29
7.4.2 Entry "Identify all modules".....	29
7.4.3 Module identification - LED blink interval.....	30
8. Module communication / PC connection.....	32
8.1 Ethernet communication via basic device.....	32
8.1.1 Connection example 1.....	32
8.1.2 Connection example 2.....	33
8.1.3 Connection example 3.....	34
8.2 Module communication options.....	35
8.2.1 Module handling in the GridVis <sup>®</sup> software.....	35
8.2.2 Basic device homepage.....	35
8.2.3 Module handling via a user interface (HMI).....	35
9. Operation and button functions of the basic device with module.....	36
9.1 Operation and button functions of the basic device with 800-CT24 module.....	36
9.2 Module-relevant menu items of the basic device with 3 modules of the type 800-CT24.....	36
10. Module-relevant configurations.....	40
10.1 LP current transformer configuration on the basic device.....	40
10.2 LP current transformer configuration in the GridVis <sup>®</sup> software.....	41
10.3 LP current transformer configuration via the device homepage of the basic device.....	42
11. Module-relevant measuring displays of the basic device with 3 modules of the type 800-CT24.....	44
12. Device views.....	52

<b>13. Technical specifications</b> .....	53
13.1 Technical data.....	53
13.2 Performance characteristics of functions (only valid in conjunction with a UMG 801 as the basic device!).....	54
<b>14. Dismounting</b> .....	55
<b>15. Module exchange/error cases</b> .....	56
15.1 Module replacement.....	56
15.2 Modules - Error cases.....	57
<b>16. Service and maintenance</b> .....	58
16.1 Repair.....	58
16.2 Service.....	58
16.3 Device adjustment.....	58
16.4 Calibration interval.....	58
16.5 Firmware update.....	58
16.6 Procedure in the event of a malfunction.....	58
16.7 Reset to factory settings.....	59
16.8 Information on saving measured values and configuration data.....	59



## 1. Information on the devices and the user manual

### 1.1 Disclaimer

Compliance with the usage information for the devices, modules and components is a prerequisite for safe operation and attaining the stated performance characteristics and product features.

Janitza electronics GmbH assumes no liability for bodily injury, material damage or financial losses which result from disregard of the usage information.

Ensure that the usage information for the products is legible and accessible.

### 1.2 Copyright notice

© 2023 - Janitza electronics GmbH - Lahnau. All rights reserved.

Any reproduction, processing, distribution or other use of this usage information, in whole or in part, is prohibited.

All trademarks and the rights arising from them are the property of the respective owners of these rights.

### 1.3 Technical changes

- Make sure that your device (modules/components) matches the user manual.
- This user manual applies to the 800-CT24 module. Separate validities and distinctions are marked.
- First make sure you have read and understood the usage information accompanying the product.
- Keep the usage information associated with the product available for the entire service life and pass it on to any possible subsequent users.
- Find out about device revisions and the associated modifications of the usage information associated with your product at [www.janitza.com](http://www.janitza.com).

### 1.4 About this user manual

If you have questions, suggestions or ideas for improvement of the user manual, please let us know via email at: [info@janitza.com](mailto:info@janitza.com).

---

#### **INFORMATION**

This user manual describes the 800-CT24 current measuring module for a suitable basic device (see "Tab. Suitable basic devices" on p. 2) and provides information about the operation of the devices and modules.

Also consult the additional usage information relevant for this user manual, such as:

- the installation manual.
- the data sheet.
- the "Safety information" supplement.
- the supplement on mounting the modules.
- the usage information on the basic device and the integrated modules of your meter and module topology.

Moreover, the **GridVis**<sup>®</sup> software has an "online help" feature.

---

#### **INFORMATION**

Our usage information uses the grammatical masculine form in a gender-neutral sense! This form always refers equally to women, men and diverse. In order to make the texts more readable, distinctions are not made. We ask for your understanding for these simplifications.

---

## 1.5 Defective device/disposal

Before sending **defective devices, modules or components** back to the manufacturer for testing:

- Contact the manufacturer's Support department.
- Send devices, modules or components complete with all accessories.
- When doing so, please bear the terms for transportation in mind.

---

### **INFORMATION**

Please return defective or damaged devices, modules or components to Janitza electronics GmbH in accordance with the shipping instructions for air or road freight (complete with accessories).

Observe special regulations for devices with built-in batteries or rechargeable batteries!

---

Do not attempt to open or repair the device (the module, the component) on your own because otherwise all warranty claims become invalid!

For the **disposal** of the device (the module, the component), please observe national regulations! Dispose of individual parts, as applicable, depending on their composition and existing country-specific regulations, for example, as

- Electronic waste,
- Batteries and rechargeable batteries,
- Plastics,
- Metals.

Engage a certified disposal company to handle scrapping as needed.

Information on "Service and maintenance" of your device can be found in Sect. 16 on page 58.

## 2. Safety

The chapter on Safety contains information which must be observed to ensure your personal safety and avoid material damage.

### 2.1 Display of warning notices and safety information

The warning notices shown below

- are found throughout the usage information.
- can be found on the devices themselves.
- indicate potential risks and hazards,
- underscore aspects of the information provided that clarifies or simplifies procedures.



The additional symbol on the device, the module or the component itself indicates an electrical hazard that can lead to severe injury or death.





This general warning symbol draws attention to a possible risk of injury. Be certain to observe all of the information listed under this symbol in order to avoid possible injury or even death.



### 2.2 Hazard levels

Warning and safety information is marked by a warning symbol, and the hazard levels are shown as follows, depending on the degree of hazard:

 <b>DANGER</b>
Warns of an imminent danger which, if not avoided, results in serious or fatal injury.
 <b>WARNING</b>
Warns of a potentially hazardous situation which, if not avoided, could result in serious injury or death.
 <b>CAUTION</b>
Warns of an immediately hazardous situation which, if not avoided, can result in minor or moderate injury.
<b>ATTENTION</b>
Warns of an immediately hazardous situation which, if not avoided, can result in material or environmental damage.

### **INFORMATION**

Indicates procedures in which there is **no** hazard of personal injury or material damage.

### 2.3 Product safety

The devices, components and modules reflect current engineering practice and accepted safety standards, but hazards can arise nonetheless.

Observe the safety regulations and warning notices. If notices are disregarded, this can lead to personal injury and/or damage to the product.

Every type of tampering with or use of the devices and the modules,

- which goes beyond the mechanical, electrical or other operating limits can lead to personal injury and/or damage to the product;
- constitutes “misuse” and/or “negligence” under the product’s warranty and thus voids the warranty for any possible resulting damage.

Read and understand the user manual and the usage information on the basic device before installing, operating, maintaining and using the devices, components and modules.

Only operate the devices, components and modules when they are in perfect condition and in compliance with this user manual and the usage information that is included. Send defective devices, components or modules back to the manufacturer in compliance with proper transport conditions.

Retain the user manual throughout the service life of your product and keep it at hand for consultation.

When using the device, component or module, also observe the legal and safety regulations for your system that are applicable for the respective use case.

## 2.4 Hazards when handling the device, components and modules

When operating electric devices, components or modules, it is unavoidable for certain parts of these devices to conduct hazardous voltage. Consequently, severe bodily injury or material damage can occur if they are not handled properly.

Therefore, when handling our devices, components, or modules, always observe the following:

- do not exceed the limit values specified in the user manual and on the rating plate! This must also be observed during testing and commissioning!
- Take note of the safety and warning notices in all usage information that belongs to the device, components or modules!

### WARNING

**Disregarding the connection conditions of the Janitza measurement devices, modules or components can lead to injuries or even death or to material damage!**

- Do not use Janitza meters, modules or components for critical switching, control or protection applications where the safety of persons and property depends on this function.
- Do not carry out switching operations with the Janitza measurement devices, modules or components without prior inspection by your system manager with specialist knowledge! In particular, the safety of persons, material assets and the applicable standards must be taken into account!

### WARNING

**Risk of injury due to electrical current and voltage!**

Severe bodily injury or death can result! Therefore please abide by the following:

- **Do not touch bare, stripped wires or device inputs that are dangerous to touch on the devices, components and modules.**
- **Switch off your installation before commencing work! Secure it against being switched on! Check to be sure it is de-energized! Ground and short circuit! Cover or block off adjacent live parts!**
- **During operation and troubleshooting (especially with DIN rail devices), check the environment for dangerous voltages and switch these off if necessary!**
- **Wear protective clothing and protective equipment in accordance with applicable guidelines when working on electrical systems!**
- **Before making connections, ground the device / component / module by means of the ground wire connection, if present!**
- **Do not touching bare or stripped leads that are energized! Equip stranded conductors with wire ferrules!**
- **Hazardous voltages can be present in all circuitry parts that are connected to the power supply.**
- **Protect wires, cables and devices with a suitable line circuit breaker/fuse!**
- **Never switch off, remove or tamper with safety devices!**
- **There can still be hazardous voltages present in the device or in the component (module) even after it has been disconnected from the supply voltage (capacitor storage).**
- **Only connect screw terminals with the same number of poles and design!**
- **Do not exceed the limit values specified in the user manual and on the rating plate! This must also be observed during testing and commissioning.**
- **Take note of the safety and warning notices in the usage information that belongs to the device, components or modules!**

## 2.5 Electrically qualified personnel

To avoid bodily injury and material damage, only electrically qualified personnel are permitted to work on the devices and their components, modules, assemblies, systems and current circuits who have knowledge of:

- The national and international accident prevention regulations.
- Safety technology standards.
- Installation, commissioning, operation, disconnection, grounding and marking of electrical equipment.
- the requirements concerning personal protective equipment.

Electrically qualified persons within the scope of the technical safety information of all usage information associated with the device and its components (modules) are persons who can furnish proof of qualification as an electrically skilled person.

### WARNING

#### **Warning against unauthorized manipulation or improper use of the device or its components (modules)!**

Opening, dismantling or unauthorized manipulation of the device and its components (modules) which goes beyond the mechanical, electrical or other operating limits indicated can lead to material damage or injury, up to and including death.

- **Only electrically qualified personnel are permitted to work on the devices and their components (modules), assemblies, systems and current circuits.**
- **Always use your devices or components (modules) only in the manner described in the associated usage information.**
- **If there is discernible damage, send the device or the component (module) back to the manufacturer!**

## 2.6 Warranty in the event of damage

Any unauthorized tampering with or use of the device, component or module constitutes "misuse" and/or "negligence" under the product's warranty and thus voids the warranty for any possible resulting damage. Note in this regard Sect. "3.3 Intended use" on p. 15.

## 2.7 Safety information for handling current transformers

The field of transformer technology groups the totality of all devices that perform the function of a current, voltage or measuring transformer together as sensors.

The usage information for our devices, modules and components contains the terms **current transformer, voltage transformer or transformer**, which are representative for **sensors**.

A further distinction is made by the terms **CT (current transformer)** and **LP-CT (low-power current transformer)**:

The term "current transformer" is used for special transformers for the primary-proportional conversion of currents of large magnitudes to directly measurable, smaller current values.

In contrast, the term "LP current transformer" (low-power current transformer) is used for special transformers for the primary-proportional conversion of currents of large magnitudes to directly measurable, smaller voltage values (low power).

**Current transformers and LP current transformers** provide safe galvanic isolation between the primary circuit and the measurement circuit due to their design and their physical operating principle. For Janitza measurement devices, modules and components, use only **"transformers for measuring purposes"** that are suitable for the energy monitoring of your system! Observe the corresponding warning notices!

Basic devices use only the term **"current transformer"** in the display for the configuration of both **current transformers** and **LP current transformers**.

**⚠ WARNING****Risk of injury or damage to the meter due to high measured currents/measured voltages at the connections of the current transformers!**

High measurement currents can cause temperatures of up to 80 °C (176 °F) on the connections of the current transformers

- **Use wiring that is designed for an operating temperature of at least 80 °C (176 °F)!**
- **Only use current transformers with basic insulation to IEC 61010-1:2010!**
- **Make sure that screw terminals for the current transformer connection on the device are adequately tightened!**
- **Comply with the information and provisions in the documentation of your current transformers!**
- **Ground connections present on the secondary windings of the current transformers must be connected to ground!**
- **The current transformers can be hot even after the power supply has been switched off. Allow the connections of the current transformers and the connecting cables to cool down before touching them!**

**⚠ CAUTION****Risk of injury or damage to the basic device (module) and/or your system due to a short circuit!**

Inadequate insulation at the current measurement inputs of the modules with respect to the supply circuits of the basic device can cause dangerous voltages at the measurement input or damage to your device (module)/system.

- **Ensure reinforced or double insulation with respect to the supply circuits!**

### 3. Product description

#### 3.1 800-CT24 current measuring module

The current measuring module

- Is suitable for basic devices of the 800 series (see "Tab. Suitable basic devices" on p. 2)
- Extends the functional range of the basic device by 24 current measuring channels.
- Is suitable for low-power current transformers with a secondary voltage of 0 .. 333 mV.
- Has an input and output (RJ45) for integration into a JanBus topology with a basic device. The 800-CT24 module requires at least one 800-CON-RJ45 module for this purpose! (The interfaces of the transfer module are proprietary RJ45 JanBus interfaces! Do not connect to RJ45 Ethernet interfaces!)

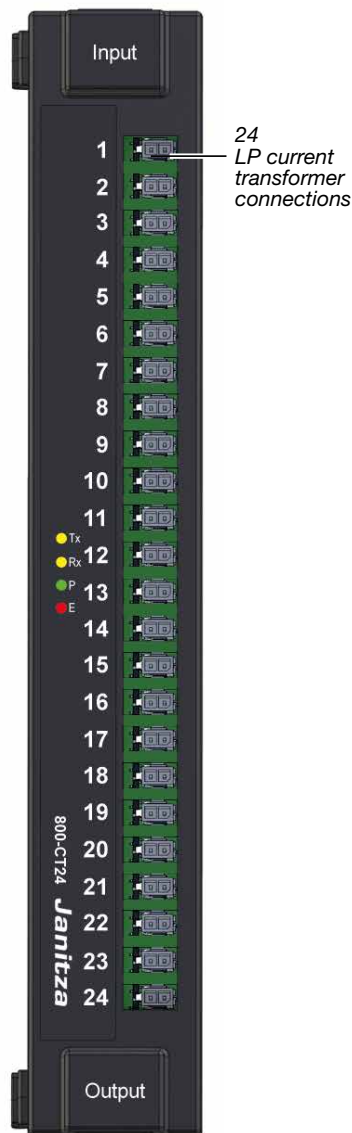

Fig.: 800-CT24 module

A basic device

- With the 800-CT24 module measures current exclusively via low-power current transformers. The LP current transformer and the primary measuring line each require basic insulation in accordance with IEC 61010-1 – alternatively, use a double-insulated LP current transformer.
- Allows integration of the 800-CT24 module into a combined JanBus topology. Please refer to the usage information for the 800-CON-RJ45 transfer module for information on this.

The number of 800-CT24 modules permitted on a basic device can be found in "Tab. Suitable basic devices" on p. 2.

#### **i** INFORMATION

- The 800-CON-RJ45 module and the RJ45 cables are not included in the scope of delivery of the 800-CT24 module!
- Do not extend the connecting cables of the LP current transformers at the current measurement inputs of the device/module! Extended measuring leads can influence the measurement result!
- Do not exceed the maximum bus length of the JanBus (see Sect. "13. Technical specifications" on p. 53)!
- In addition to the usage information for the 800-CT24 module, also observe all usage information for the modules and components integrated in the JanBus topology, especially that of your basic device!

Please refer to the definition of the terms "current sensors", "current transformers" and "low-power current transformers" on p. 12 in this user manual!

#### **⚠** WARNING

**Damage to the device/module or your installation even including life-threatening injuries due to a short circuit.**

Insufficient insulation of the equipment (LP current transformers) at the current measurement inputs with respect to the circuits can lead to life-threatening voltages or damage to your device, module or system.

- **Observe the information and specifications for your LP current transformer concerning insulation and ensure end-to-end double insulation of your LP current transformers to mains and measuring circuits!**

### 3.2 Incoming goods inspection

The prerequisites for trouble-free and safe operation of the module include proper transport, storage, setup and assembly, as well as proper operation and maintenance.

Exercise due caution when unpacking and packing the device, do not use force and only use suitable tools. Check the following:

- the module by performing a visual inspection to ensure flawless mechanical condition.
- the scope of delivery (see Sect. "3.8 Scope of delivery" on p. 16) for completeness before beginning with assembly and installation.

If it must be assumed that safe operation of your basic device with module is not possible:

1. **Switch off the power to your system (your device)!**
2. **Secure it against being switched back on!**
3. **Check to be sure it is de-energized!**
4. **Ground and short circuit the system (device)!**
5. **Cover or block off adjacent live parts!**

Safe operation is impossible, if, for example, the basic device with module:

- Has visible damage,
- No longer functions despite an intact power supply,
- Was subjected to extended periods of unfavorable conditions (e.g. storage outside of the permissible climate thresholds without adjustment to the room climate, condensation, etc.) or transport stress (e.g. falling from an elevated position, even without visible external damage, etc.).

#### **ATTENTION**

##### **Improper handling may cause damage to the module and result in material damage!**

The contacts of the bus connectors (JanBus interface) can bend or break off and destroy the bus connector.

- **Never touch or manipulate the contacts of the bus connector!**
- **Never force the bus connector into the module! Please note Sect. "4. Mounting" on p. 18 in this regard.**
- **When handling, transporting and storing the module, protect the contacts of the bus connector!**

### 3.3 Intended use

The module / component

- is only for use in the industrial sector.
- is intended as an expansion module for a basic device (see "Tab. Suitable basic devices" on p. 2) in switchboard cabinets and small distribution boards.
- Must only be mounted with basic devices that are disconnected from the power supply (see Sect. "4. Mounting" on p. 18).

#### **i INFORMATION**

**More information on certain functions of the basic device with modules can be found in the usage information of the basic device.**

The basic device and the modules are **not** designed for installation:

- In vehicles! Use of the basic device with modules in non-stationary equipment is considered an exceptional environmental condition and is only permissible by special agreement.
- In environments with harmful oils, acids, gases, vapors, dusts, radiation, etc.
- In potentially explosive environments.

### 3.4 Overview of module functions

Functions of the 800-CT24 module:

- 24 current measurement inputs
- Measuring category 300 V CAT II
- Suitable for LP current transformers with a secondary voltage of 0 .. 333 mV.
- The maximum bus length (JanBus - proprietary) for setting up measurement device and module topologies can be found in Sect. "13. Technical specifications" on p. 53.

### 3.5 EU/UKCA Declaration of Conformity

Please see the EU/UKCA declarations of conformity posted at [www.janitza.com](http://www.janitza.com) for the laws, standards and directives applied by Janitza electronics GmbH for the devices. The EU/UKCA conformity of the device permits the marking CE/UKCA.

### 3.6 FCC Declaration of Conformity



The device

- complies with Part 15 of the FCC Rules for Class B digital devices (limits to protect against harmful interference in a residential installation).
- generates, uses and can radiate high-frequency energy
- can cause harmful interference to radio communications if not installed and used properly. There is no guarantee that interference will not occur in a particular installation.

If there is radio or television reception interference, which can be determined by turning the device on and off, proceed as follows:

- Align or reposition the receiving antenna.
- Increase the distance between the device and the radio/television receiver.
- Connect the device and the radio/television receiver in different circuits.
- if necessary, contact Janitza support or a radio/television technician.

*Code of Federal Regulations, Title 47, Part 15, Subpart B - Unintentional Radiators.*

### 3.7 Protective device/transformer

It is not permitted to use the outputs of Janitza measurement devices, components and modules for switching protective devices or protective relays! Use only "Current transformers for measuring purposes" for Janitza measurement devices, components and modules!

### 3.8 Scope of delivery

Quantity	Part. no.	Designation
1	52.31.213	Module 800-CT24 (current measuring module)
1	33.03.887	Installation manual (DE/EN)
1	33.03.342	"Safety Information" supplement

*Tab. Scope of delivery, 800-CT24 current measuring module*

### INFORMATION

- The modules are delivered with the necessary screw terminals and bus connectors (JanBus interface) for connection to the basic device or other modules.
- All supplied options and design variants are described on the delivery note.
- The GridVis® network analysis software is available at [www.janitza.com](http://www.janitza.com) and can be used to configure your basic device with modules and read out data for analysis (prerequisite: PC connection to your basic device).

### 3.9 Accessories

Quantity	Part. no.	Designation
1	52.31.242	Module 800-CON-RJ45 (transfer module)
1	10.01.953	End bracket
<b>LP current transformer with secondary voltage 0 .. 333 mV (length of the connecting cable)</b>		
1	15.03.124	LP current transformer up to 50 A (primary current) (2 m)
1	15.03.125	LP current transformer up to 75 A (primary current) (2 m)
1	15.03.126	LP current transformer up to 100 A (primary current) (2 m)
1	15.03.127	LP current transformer up to 50 A (primary current) (0.25 m)
1	15.03.128	LP current transformer up to 75 A (primary current) (0.25 m)
1	15.03.129	LP current transformer up to 100 A (primary current) (0.25 m)

*Table of available accessories for 800-CT24 current measuring module*

### 3.10 Operating concept

For meter and module topologies, modules have the following options for configuring or reading out measured values:

- Display and buttons on the basic device (user interface).
- The GridVis® network analysis and programming software® for programming and analysis of data.
- Via the RS-485 interface or Ethernet interface.
- If applicable Web server with device homepage of the basic device for analysis and configuration of the essential measurement device and module parameters (see usage information for the basic device).
- If necessary, via an HMI (human machine interface) integrated in the project.

The modules can be used to realize measurement device and module topologies with a flexible arrangement of the DIN rails (for examples of this, see Sect. "8. Module communication / PC connection" on p. 32). For the operation of the devices, components and modules integrated in your meter and module topology, please refer to the respective additional usage information.

---

#### **INFORMATION**

This user manual describes modules and provides information on operating the modules via a basic device.

Please refer to the user manual for the basic device for information on operating, configuring and reading out expansion modules.

The GridVis® software has an online help with tutorials.

**A list of parameters and Modbus addresses with data on your basic device with module can be found in the download area at [www.janitza.com](http://www.janitza.com).**

---

### 3.11 GridVis® network analysis and programming software

With the GridVis® software, you have the perfect tool for programming, reading out and visualizing measurement data (download at [www.janitza.com](http://www.janitza.com)).

#### **Performance characteristics of the GridVis® software**

- Configuration of the basic device and the modules of your meter and module topology.
- Graphic display of measured values.
- Report functions.
- Online help and tutorials.

#### **Connections to the PC (GridVis® software)**

Information on connections for communication between the PC and the basic device (with modules) can be found in the usage information of the basic device.

## 4. Mounting

### 4.1 Mounting the 800-CT24 module with 800-CON RJ45 transfer module

#### CAUTION

**Disregard of the installation instructions may cause property damage or personal injury!**  
Disregard of the installation instructions may cause damage to your basic device with module or destroy it and/or may also result in personal injury.

- **In addition to the installation instructions for your module, also observe the installation instructions for your basic device, in particular the safety and warning information.**
- **Before installing modules**
  - **Disconnect the supply of power to the system!**
  - **Secure it against being switched on!**
  - **Check to be sure it is de-energized!**
  - **Ground and short circuit!**
  - **Cover or block off adjacent live parts!**
- **Operate the basic device that belongs to the 800-CT24 module only with a supply voltage of 24 V! Observe the technical specifications in the usage information for the basic device.**
- **Provide adequate air circulation in your installation environment and cooling, as needed, when the ambient temperatures are high.**
- **Return defective modules to Janitza electronics GmbH in accordance with the shipping instructions for air or road freight (complete with accessories).**
- **All usage information is available for download at [www.janitza.com](http://www.janitza.com).**

Observe the mounting instructions for your basic device and 800-CON RJ45 transfer module (e.g. check bus connector installation!) and mount the 800-CT24 module in the de-energized system as follows:

- ①. Press your 800-CT24 module onto the DIN rail until the bottom bolts engage.
- ②. Connect the 800-CON RJ45 module to the input side of the 800-CT24 module. Use a commercially available Ethernet cable (**RJ45 cable for JanBus communication!**) for this purpose.
- ③. Connect the output side of the 800-CT24 module to
  - the input side of the next 800-CT24 module.
  - an additional 800-CON-RJ45 transfer module to expand the JanBus topology (see Sect. “4.2 The 800-CT24 module in JanBus module topologies” on p. 20)

The basic device automatically recognizes the module during the power-up procedure! The number of 800-CT24 modules permitted on a basic device can be found in “Tab. Suitable basic devices” on p. 2.

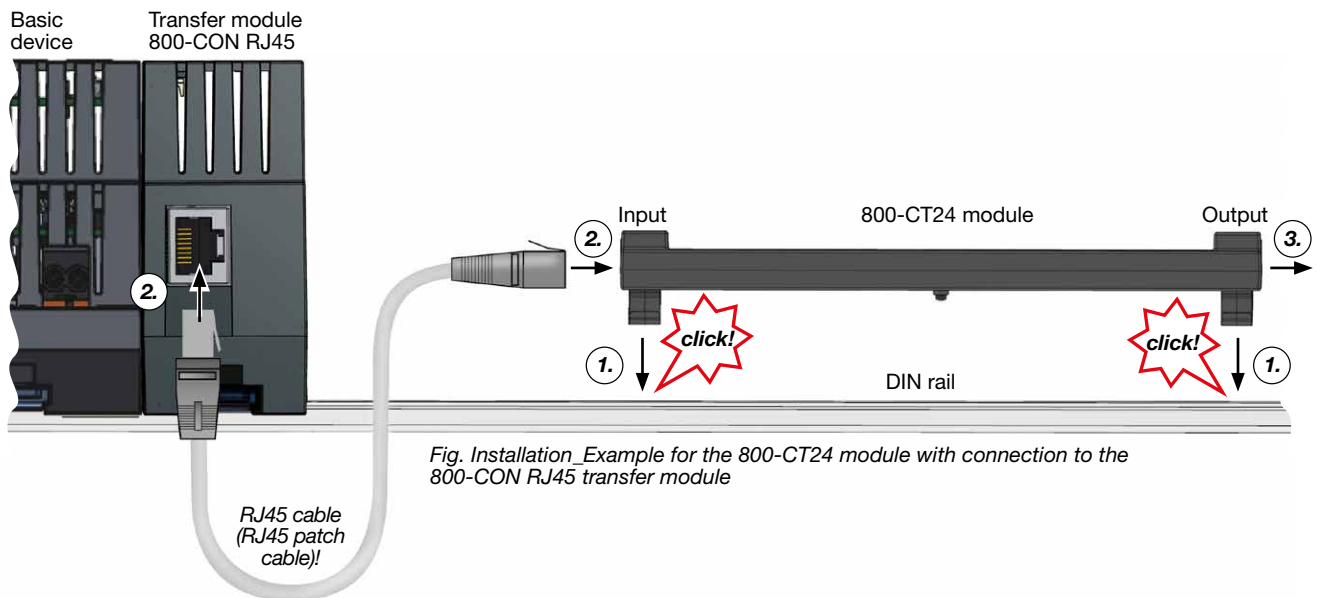

Fig. Installation\_Example for the 800-CT24 module with connection to the 800-CON RJ45 transfer module

### ATTENTION

**The basic device does not recognize the module during the power-up procedure!**

If there is no communication to the module, the module functions are not supported (e.g. current measurements).

- **Disconnect your system from the power supply and check the RJ45 cable and the connection of the module to the basic device (seating of the contacts of the RJ45 module).**
- **The interfaces of the module are proprietary RJ45 JanBus interfaces! Do not connect to RJ45 Ethernet interfaces!**
- **If necessary, restart the basic device.**
- **If these measures do not lead to the desired result, please contact Janitza Support – [www.janitza.com](http://www.janitza.com).**

## 4.2 The 800-CT24 module in JanBus module topologies

Before setting up a JanBus module topology, please check the number of free module slots in suitable basic devices (see “Tab. Suitable basic devices” on p. 2). When planning a JanBus measurement device and module topology in a switchboard cabinet or small distribution board, it is important to make optimum use of the slots in the basic device.

Taking into account that an 800-CT24 current measuring module occupies 3 slots of the basic device and, in the best case, all basic device slots are occupied in a JanBus topology, the following example topologies can be realized.

1. A **combined JanBus topology** consisting of modules, each occupying one module slot, and the 800-CT24 current measuring modules, each occupying 3 module slots. See fig. „4.2.1 Topology example: Combined module topology with 800-CT24 module“ on page 21.
2. A **JanBus 800-CT24 topology** consisting of 3 current measuring modules of the type 800-CT24, which together occupy 9 slots. See fig. „4.2.2 Topology example: 3 modules of the type 800-CT24“ on page 21.

---

### **i** INFORMATION

In addition to the example topologies mentioned, there are many options and combinations for other measurement device and module topologies.

Note the following for the setup and dimensioning of your measurement device and module topology:

- 1 module of type 800-CT24 has 24 current measuring channels.
- The usage information of measurement devices, modules and components of your topology, in particular the usage information of the 800-CON-RJ45 transfer module!
- The interfaces of the 800-CT24 module are proprietary RJ45 JanBus interfaces! Do not connect to RJ45 Ethernet interfaces!
- Use a commercially available RJ45 cable (RJ45 patch cable) for trouble-free JanBus communication in your measurement device and module topology.
- Use end brackets to set up your measurement device and module series on the DIN rails.

#### **System limits:**

- Before mounting, please check the number of suitable modules (slot requirements) for your measurement device and module topology based on the respective usage information (see Sect. “Tab. Suitable basic devices” on p. 2)! The 800-CON-RJ45 transfer module does not occupy a slot!
  - The maximum bus length of the JanBus can be found in Sect. “13. Technical specifications” on p. 53.
-

### 4.2.1 Topology example: Combined module topology with 800-CT24 module

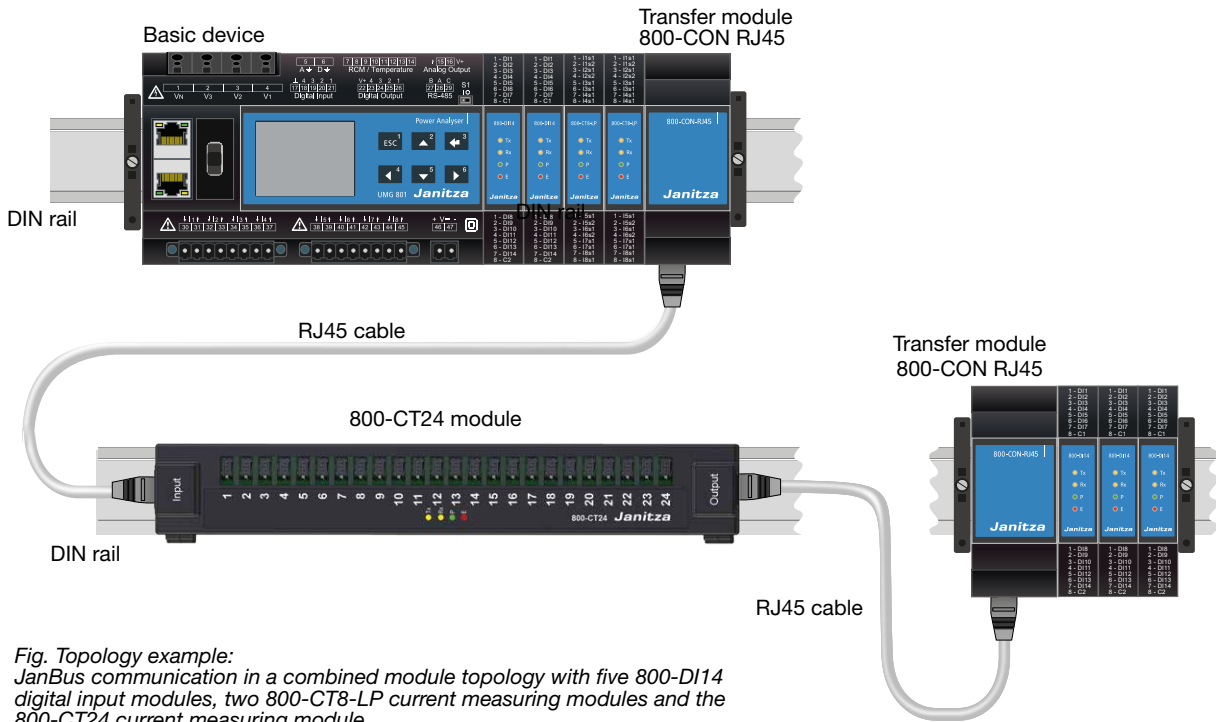

Fig. Topology example: JanBus communication in a combined module topology with five 800-DI14 digital input modules, two 800-CT8-LP current measuring modules and the 800-CT24 current measuring module.

### 4.2.2 Topology example: 3 modules of the type 800-CT24

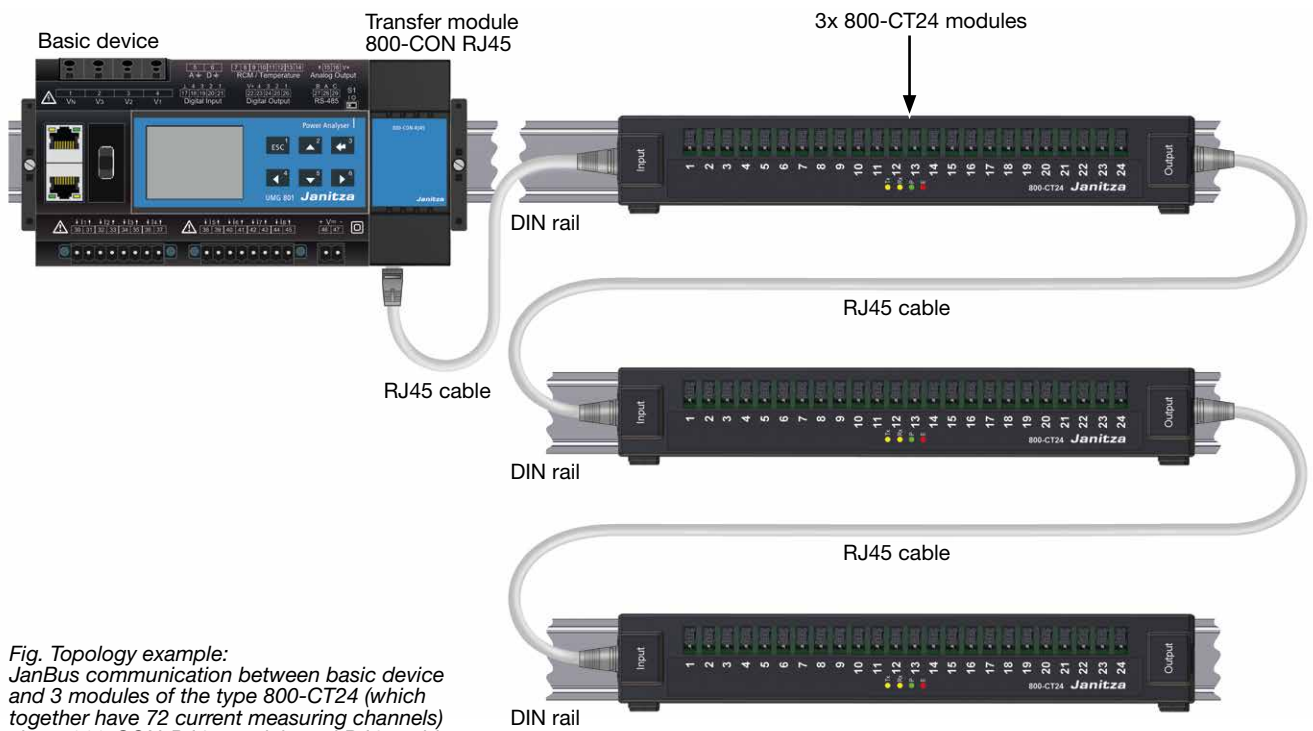

Fig. Topology example: JanBus communication between basic device and 3 modules of the type 800-CT24 (which together have 72 current measuring channels) via an 800-CON-RJ45 module and RJ45 cable.

### 4.3 Checking module communication

After installing your module, check the function of the communication between the basic device and the module using the display on the basic device as follows:

- When you are in the *Home* measuring display of the basic device, pressing the button 1 *ESC* takes you to the *Menu* window.
- Use buttons 2 ( $\blacktriangle$ ) and 5 ( $\blacktriangledown$ ) to select the menu item *System information* and confirm with button 3 *Enter*.
- The *System information* window with the items *Basic device* and *Module 1* appears.

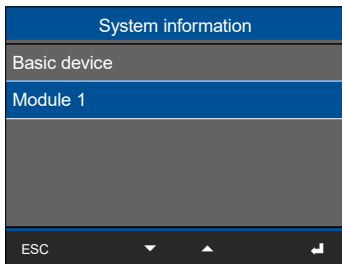

Fig.: System information window with the entries of the basic device and module 1.

- The basic device has detected module 1.

#### **i** INFORMATION

- The permitted number of modules of the type 800-CT24 is determined by the number of free module slots in the suitable basic device(s) (see “Tab. Suitable basic devices” on p. 2).
- Option: The basic device and the connected modules can be renamed in the GridVis® software.

### 4.4 System information on the module

To obtain information about a module in your measurement device and module topology, proceed as in the following example - **Basic device with 3 modules** - described below:

- When you are in the *Home* measuring display of the basic device, pressing the button 1 *ESC* takes you to the *Menu* window.
- Use buttons 2 ( $\blacktriangle$ ) and 5 ( $\blacktriangledown$ ) to select the menu item *System information* and confirm with button 3 *Enter*.
- The *System information* window with the items *Basic device*, *Module 1*, *Module 2* and *Module 3* appears.

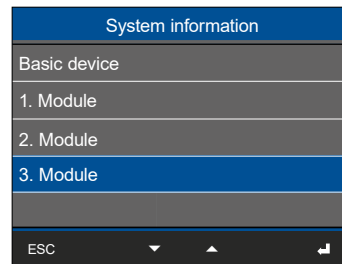

Fig.: System information window with the items of the measurement device and module topology

- Use buttons 2 ( $\blacktriangle$ ) and 5 ( $\blacktriangledown$ ) to select, for example, the item *Module 3* and confirm with button 3 *Enter*.
- The *Module 3 Info 1/2* window with the items *Type*, *Serial number* and *Position* appears.

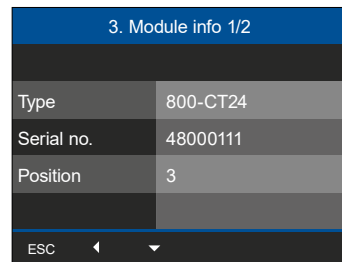

Fig.: Module 3 Info 1/2 window

- Press button 5 (▼) to open the *Module 3 Info 2/2* window with the items *HW version*, *SW version* and *SW build*.

3. Module info 2/2	
HW version	62381
SW version	9.9.9
SW build	abc999-ebgxm
	0 b0
ESC	◀ ▶

Fig.: Module 3 Info 2/2 window

- Use button 1 *ESC* to return to the *Menu* window.

#### 4.5 Faulty module communication

Error after starting the basic device with module:

##### **i** INFORMATION

**The basic device does not recognize modules during the power-up procedure!**

If there is no communication to the modules, the module functions are not supported.

- **Disconnect your system from the power supply and check the condition of the bus connectors and the connections of your modules to the basic device (JanBus interface). If necessary, push the contacts of the module bus connectors into the sockets of the basic device bus connector or the attached modules so that the bus connectors (devices) are coupled.**
- **For remote module series, check the connection with the transfer module.**
- **If necessary, restart the basic device.**
- **If these measures do not lead to the desired result, please contact our Support**  
– [www.janitza.com](http://www.janitza.com)

## 5. Connections/controls

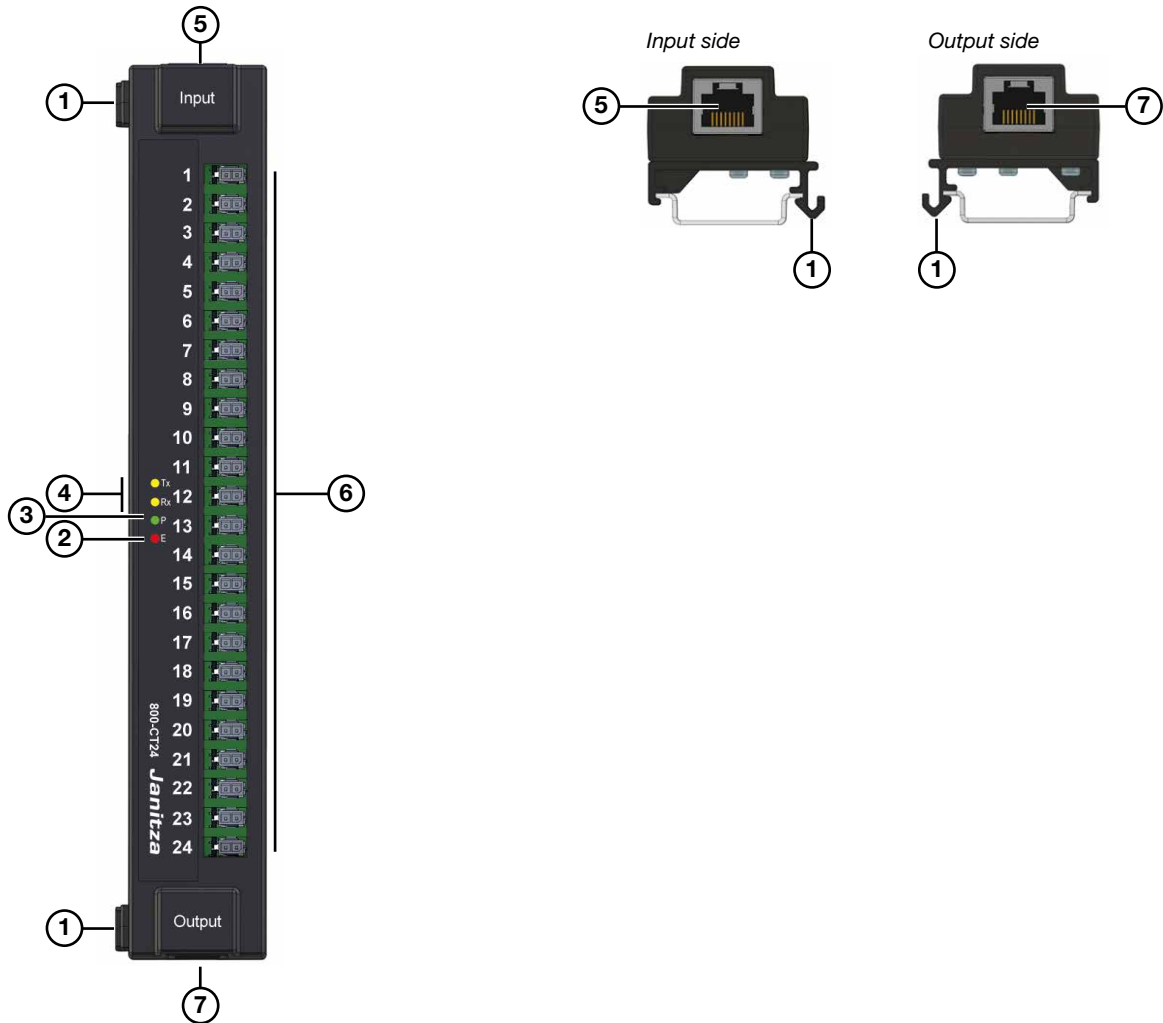

Item	Designation	Description
1	Bottom bolt (retaining brackets)	For mounting the module on the DIN rail
2	LED (E ... Error)	Lights "red" during initialization/startup and in the event of a fault (error). Note in this regard Sect. "15.2 Modules - Error cases" on p. 57.
3	LED (P ... Power)	Lights "green" if the supply of power via the JanBus interface of the basic device is correct; the device is ready for operation.
4	2 LEDs (Tx ... Transmit data, Rx ... Receive data)	Blink "orange" during operation and indicate cyclic data exchange.
5	RJ45 interface - input	<ul style="list-style-type: none"> <li>Interface input for integrating the module into the JanBus-device and module topology.</li> <li>JanBus (proprietary) via RJ45 cable (commercially available Ethernet cable).</li> </ul>
6	24 LP current transformer interfaces	24 LP current transformer connections
7	RJ45 interface - output	<ul style="list-style-type: none"> <li>Interface output for integration of further modules into the JanBus-device and module topology.</li> <li>JanBus (proprietary) via RJ45 cable (commercially available Ethernet cable).</li> <li>The maximum bus length of the JanBus can be found in Sect. "13. Technical specifications" on p. 53.</li> </ul>

Tab. Connections and controls

## 6. Module markings – rating plate

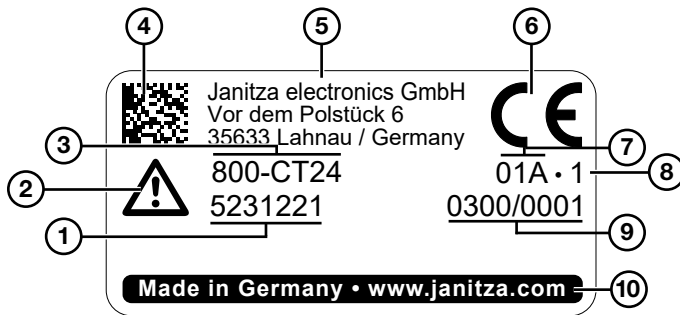

Item	Designation	Description
1	Part number	Marking for traceability
2	Symbol for “Danger sign”	General hazard symbol. Be certain to observe the warning notices applied to the device and shown in the documentation in order to avoid possible injury or even death.
3	Device description (identification)	Device designation (model, device type)
4	DataMatrix code	Coded manufacturer data
5	Manufacturer	Complete contact address of the manufacturer (company name, street, house number, postal code, city, country)
6	CE conformity marking	See Sect. “3.5 EU/UKCA Declaration of Conformity” on p. 16
7	Manufacturer-specific data	Manufacturer data (date of manufacture)
8	Hardware version	Hardware version of the module
9	Type/serial number	Number for identification of the device
10	Designation of origin/web address	Country of origin and manufacturer’s web address

Tab. Identification of the module - rating plate

## 7. Installation

### **⚠ WARNING**

#### **Risk of injury due to high currents and high electrical voltages!**

Severe bodily injury or death can result from:

- Touching bare or stripped leads that are energized.
- Inputs of devices, components and modules are dangerous to touch.

Therefore, please note for your system:

- **Disconnect the supply of power before starting work!**
- **Secure it against being switched on!**
- **Check to be sure it is de-energized!**
- **Ground and short circuit! Use the ground connection points with the ground symbol for grounding!**
- **Cover or block off adjacent live parts!**

### **⚠ CAUTION**

#### **Risk of injury or damage to the device due to high measurement currents at the connections of the current transformers or the current measurement inputs of the device!**

High measurement currents can cause temperatures of up to 80 °C (176 °F) on the connections of the current transformers

- **Use wiring that is designed for an operating temperature of at least 80 °C (176 °F)!**
- **The current transformers can be hot even after the power supply has been switched off. Allow the connections of the current transformers and the connecting cables to cool down before touching them!**
- **Make sure that screw terminals for the current transformer connection on the device are adequately tightened!**
- **Ground connections present on the secondary windings of the current transformers must be connected to ground!**
- **Observe the general safety information for handling current transformers in section Sect. "2.7 Safety information for handling current transformers" on p. 12.**
- **Comply with the information and provisions in the usage information of your current transformers!**

### **⚠ WARNING**

#### **Of electrical currents and voltages!**

Current transformers  $\cdot/5$  A (1 A) operated while open on the secondary side (with current output on the secondary side) can result in severe bodily injury or death (high voltage peaks).

**Avoid exposed operation of the current transformers. Short-circuit unloaded transformers!**

### 7.1 Current measurement with the module

The 800-CT24 module

- Measures current exclusively via LP current transformers.
- Allows the connection of LP current transformers with a secondary voltage of 0 .. 333 mV.
- Does not measure DC currents.

**Please refer to the definition of the terms "current transformers" and "current sensors" in section Sect. "2.7 Safety information for handling current transformers" on p. 12 in this user manual!**

### **i INFORMATION**

You can configure the LP current transformer ratios via the user interface of the basic device, possibly the device homepage, or conveniently using the "Device configuration" function of the GridVis® software.

### **ATTENTION**

#### **Incorrectly dimensioned or connected LP current transformer connections can lead to material damage!**

Interchanged LP current transformer terminals ("k" and "l") or incorrectly dimensioned LP current transformers can lead to incorrect measurement results and/or incorrect control behavior!

- When connecting an LP current transformer, it is essential to observe the markings on the transformer!
- The polarity of the LP current transformers and thus the "energy flow direction" runs from "k" to "l"! The polarity of the LP current transformers may vary depending on the model!
- Also observe the technical connection requirements and the markings on the rating plate of your LP current transformers.

### 7.2 Startup procedure/initialization

Modules started on a basic device (e.g. current measuring modules or digital input modules) trigger a blink interval of the LEDs. The blink interval of the LEDs and the meaning can be found in Sect. "7.4.3 Module identification - LED blink interval" on p. 30.

### 7.3 Connection diagram "Current measurement" for 1st 800-CT24 module

The following example in the figure shows the connection diagram, for example, for current measurement via LP current transformers on the first 6 current measuring channels of the 800-CT24 module (measurements on two L1-L3 systems).

One 800-CT24 module in a JanBus topology measures 24 current measuring channels.

RJ45 cable to the basic device via 800-CON RJ45 module

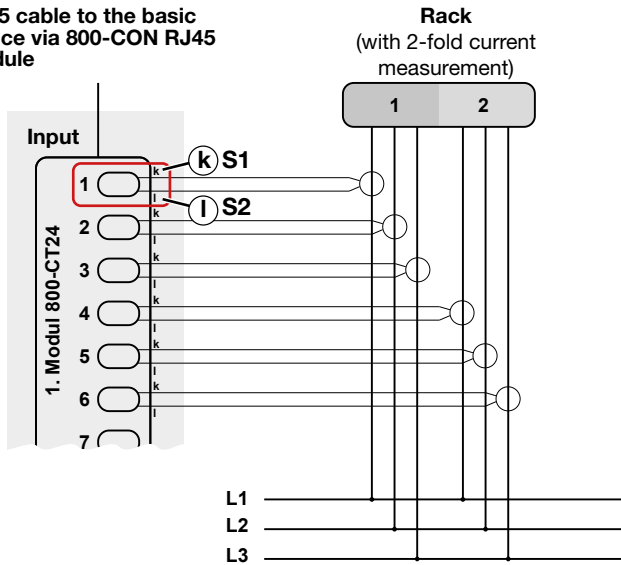

Fig. Connection diagram - Current measurement using LP current transformers

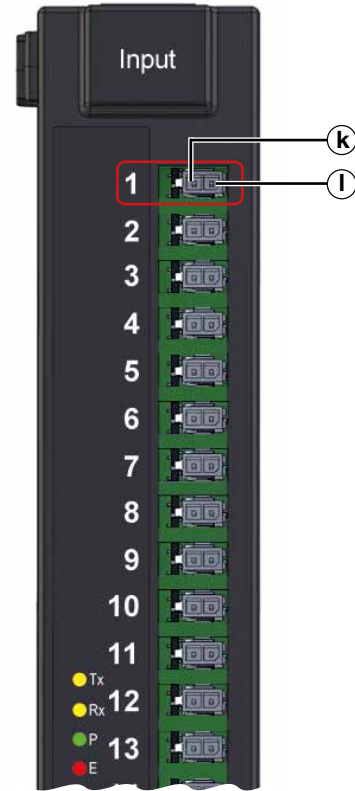

Fig. 800-CT24 module - LP current transformer connection "k" and "I"

#### **i** INFORMATION

The basic device automatically detects and corrects LP current transformer connections with reversed polarity! Nevertheless, connect the LP current transformers as recommended!

## 7.4 Module identification / Diagnostics on the basic device

### **i** INFORMATION

Before you start the module identification function (*Diagnostics* menu item) on the basic device, please make sure that the modules are mounted and connected correctly. Only correctly installed modules connected to the basic device guarantee the supply of power and data transmission.

The basic device provides the option of extending the range of functions using current measuring modules or digital input modules. The basic device automatically recognizes the module during the power-up procedure.

The Diagnostics menu item of the basic device is used to identify modules that are located at remote measurement points. After starting the module identification, the LEDs of the modules being searched for blink at an interval (see Sect. "7.4.3 Module identification - LED blink interval" on p. 30).

**The module identification can be configured via the *Diagnostics* menu item of the basic device. Then proceed as follows:**

- Press function button 1 *ESC* to open the menu.
- Use buttons 2 "▲" and 5 "▼" to select the menu item *Diagnostics* and confirm with button 3 *Enter*.
- The *Diagnostics* window appears.

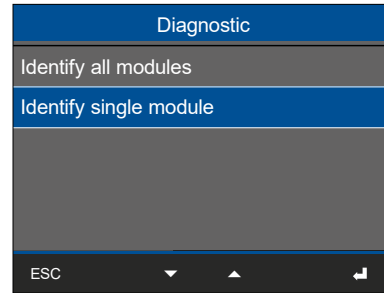

Fig. Window: Diagnostics with entries

- In the *Diagnostics* window, use keys 2 "▲" and 5 "▼" to select the entry *Identify all modules* or *Identify one module*. These mean:

<b>Identify all modules</b>	Simultaneously identifies <b>all</b> current measuring modules or digital input modules connected to a basic device.
<b>Identify one module</b>	Identifies <b>one</b> module (current measuring module or digital input module) from the module topology of your basic device.

### 7.4.1 Entry "Identify one module"

- In the *Diagnostics* window, use buttons 2 "▲" and 5 "▼" to select the menu item *Identify one module* and confirm with button 3 *Enter*.
- The *Identify one module* window appears.

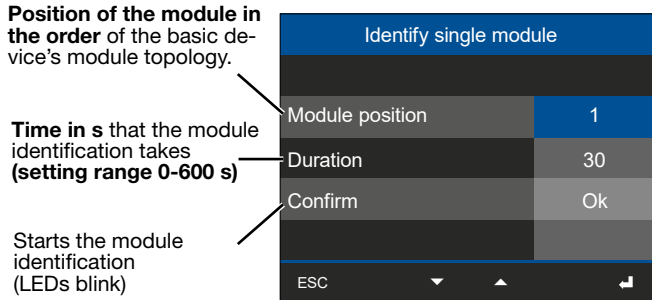

Fig. Window: Identify one module

- In the *Identify one module* window, use keys 2 "▲" and 5 "▼" to select the menu item *Module position* and confirm with key 3 *Enter*.
- The entry *Module position* blinks.
- Use the keys 2 "▲" and 5 "▼" to enter the position number of the module to be identified (the position number depends on the number of modules connected in series to the basic device).
- Confirm the entry with key 3 *Enter*.
- Use keys 1 *ESC* and key 5 "▼" to access the entry *Duration*.
- Press button 3 *Enter*.
- The first digit of the entry *Duration* blinks.
- Use buttons 4 (◀) and 6 (▶) to change the position of the digit to be set and buttons 2 (▲) and 5 (▼) to change the digit (-1/+1).
- Confirm your entries with key 3 *Enter*.
- Use keys 1 *ESC* and key 5 "▼" to access the entry *Confirm*.
- Press button 3 *Enter*.
- In the entry *Confirm*, *OK* blinks.
- Pressing button 3 *Enter* starts the module identification with a blink interval of the LEDs on the corresponding module (see Sect. "7.4.3 Module identification - LED blink interval" on p. 30).

### 7.4.2 Entry "Identify all modules"

- In the *Diagnostics* window, use buttons 2 "▲" and 5 "▼" to select the menu item *Identify all modules* and confirm with button 3 *Enter*.
- The window *Identify all modules* appears.

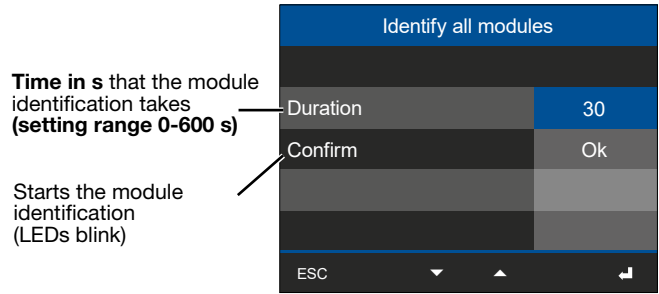

Fig. Window, Identify all modules

- In the *Identify all modules* window, use buttons 2 "▲" and 5 "▼" to select the menu item *Duration* and confirm with button 3 *Enter*.
- The first digit of the entry *Duration* blinks.
- Use buttons 4 (◀) and 6 (▶) to change the position of the digit to be set and buttons 2 (▲) and 5 (▼) to change the digit (-1/+1).
- Confirm your entries with key 3 *Enter*.
- Use keys 1 *ESC* and key 5 "▼" to access the entry *Confirm*.
- Press button 3 *Enter*.
- In the entry *Confirm*, *OK* blinks.
- Pressing button 3 *Enter* starts the identification of all modules using a blink interval of the LEDs (see Sect. "7.4.3 Module identification - LED blink interval" on p. 30).

### 7.4.3 Module identification - LED blink interval

The module identification (diagnostics) procedure started on the basic device triggers a blink interval of the LEDs on the modules (e.g. current measuring modules or digital input modules). The blink interval of the functions **Identify one module** and **Identify all modules** works the same way for a single module or for all modules!

#### LED status of the module in operation:

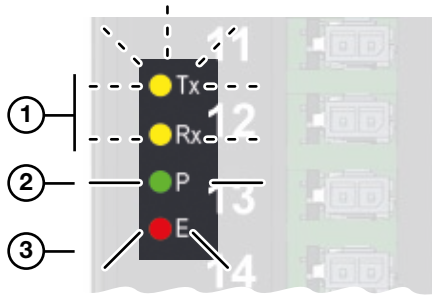

Fig.: LED status during operation

Item	Description
1	Blink "orange" during operation and signaling cyclic data exchange (Tx ... Transmit data, Rx ... Receive data).
2	Lights "green" if the supply of power via the JanBus interface of the basic device is correct, the device is ready for operation (P ... Power).
3	Lights "red" during initialization/startup and in the event of a fault (error). <b>Note in this regard Sect. "15.2 Modules - Error cases" on p. 57.</b>

#### LED status of the module during module identification:

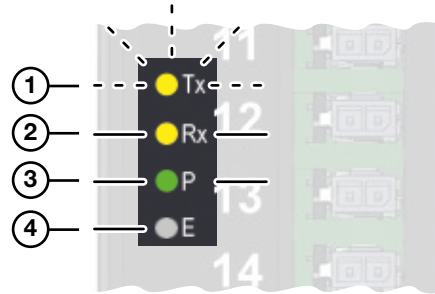

Fig.: LED status during module identification

Item	Description
1	Blinks "orange" for the <i>Duration</i> of the module identification.
2	Lights "orange" for the <i>Duration</i> of the module identification.
3	Lights "green".
4	"Off"

#### **i** INFORMATION

During the **Duration of individual module identification**, the blink intervals of all other modules connected to the basic device are paused!



## 8. Module communication / PC connection

### 8.1 Ethernet communication via basic device

The PC connections of the basic device or your module series via the Ethernet interfaces are shown below using the UMG 801 as an example for other basic devices.

The basic device has two Ethernet interfaces for communication with the 800-CT24 current measuring module (via module 800-CON RJ45).

#### **i** INFORMATION

**The interfaces of the 800-CT24 module are proprietary RJ45 JanBus interfaces! Do not connect to RJ45 Ethernet interfaces!**

Use the two RJ45 Ethernet interfaces on the basic device to configure, manage and monitor your basic device with the modules in a measurement device and module topology.

For the modules assigned to a basic device, this creates communication options via

- The display and buttons of your basic device.
- An HMI (human machine interface) integrated into your measurement device and module topology.
- A network with a PC running the GridVis® software or a generic OPC UA client.
- The homepage of the basic device, if applicable.

#### 8.1.1 Connection example 1

Schematic representation of the Ethernet communication of the modules in a measurement device and module topology with connection to a PC and DHCP server.

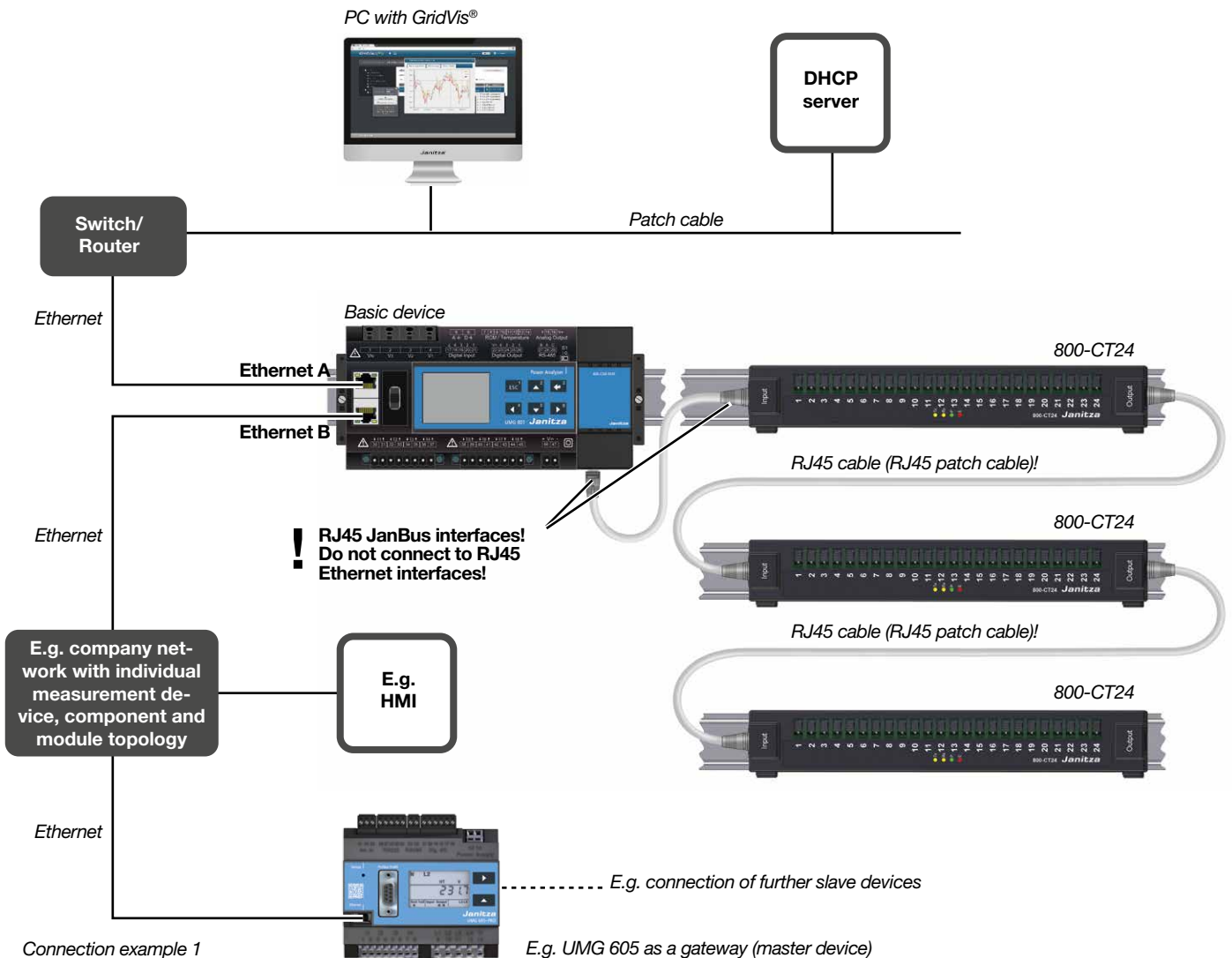

### 8.1.2 Connection example 2

Schematic representation of the Ethernet communication of the modules in a measurement device and module topology with PC and OPC UA client and connection to an RS-485 Modbus structure.

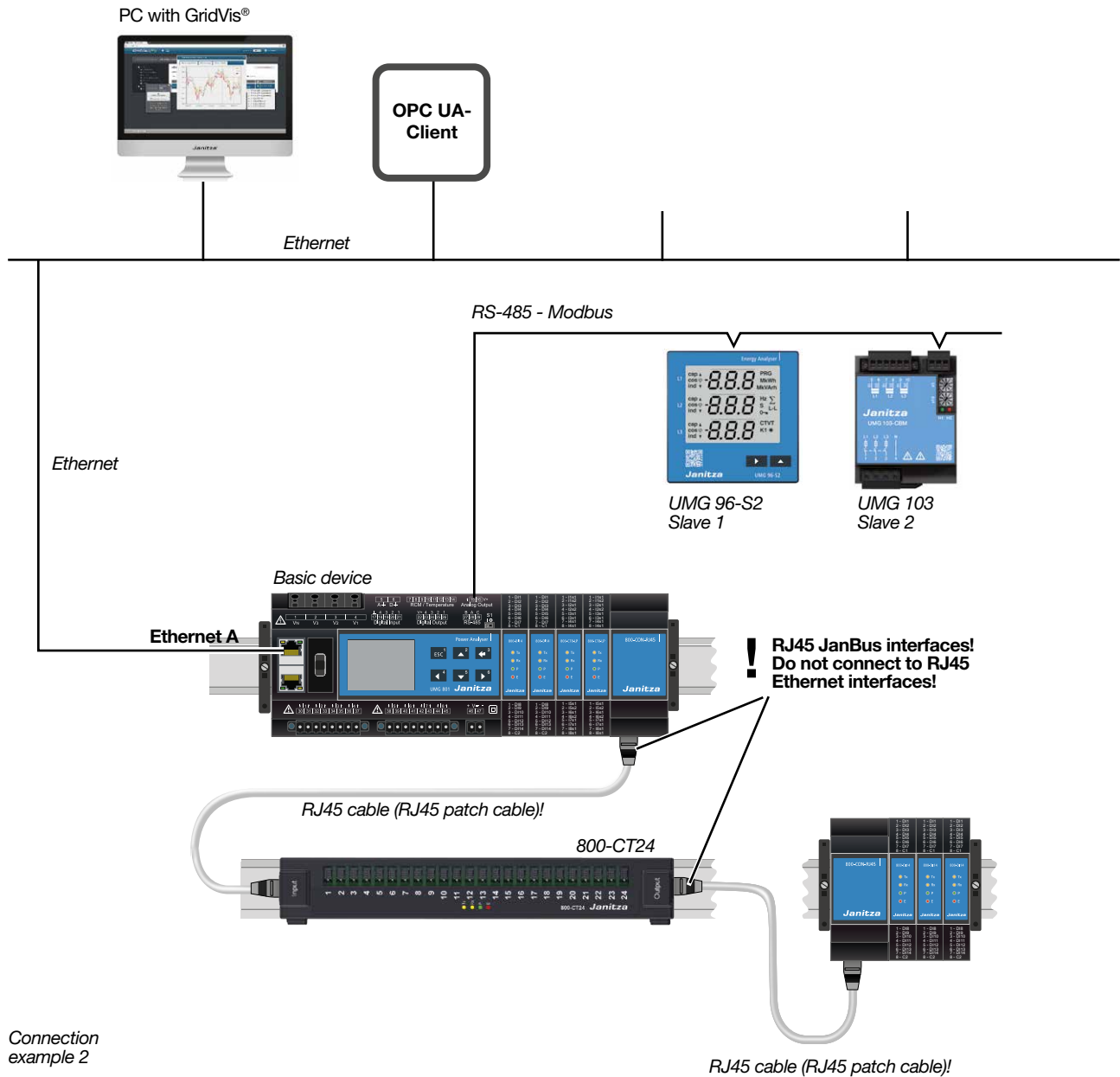

Connection example 2

### 8.1.3 Connection example 3

Schematic representation of the Ethernet communication of the modules in a measurement device and module topology with direct PC connection.

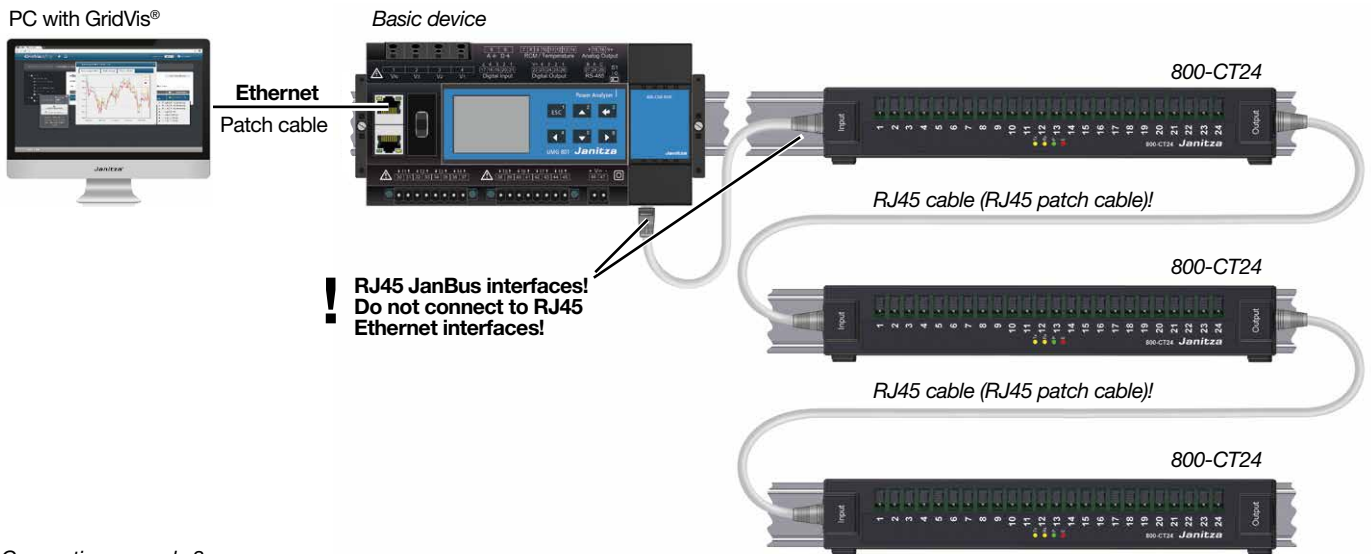

Connection example 3

#### **i** INFORMATION

Descriptions of the Ethernet interfaces can be found in the user manual for the basic device.

#### **ATTENTION**

**Material damage due to security vulnerabilities in programs, IT networks and protocols.**

Security vulnerabilities can lead to data misuse and faults and even the standstill of your IT infrastructure.

**To protect your IT system, network, data communications and measurement devices:**

- Inform your network administrator and/or IT representative.
- Always keep the meter firmware up to date and protect the communication to the meter with an external firewall. Close unused ports.
- Take protective measures against viruses and cyber attacks from the Internet, e.g. through firewall solutions, security updates and virus protection programs.
- Eliminate security vulnerabilities and update or renew existing protection for your IT infrastructure.

#### **ATTENTION**

**Material damage due to incorrect network settings.** Incorrect network settings can cause faults in the IT network!

**Consult your network administrator for the correct network settings for your device.**

## 8.2 Module communication options

### 8.2.1 Module handling in the GridVis® software

The user interface of the GridVis® network analysis software uses a graphical representation to show the modules connected to the basic device.

A user can configure various types of module handling in the GridVis® software, including:

- Automatic module recognition
- Module addition at the end of the module topology of a basic device.
- Module addition within the module topology of a basic device.
- Module removal at the end of the module topology of a basic device.
- Module removal within the module topology of a basic device.
- Module swap.
- Module configuration swap (measurement).
- Data storage and data transfer.
- Swap out basic device.

---

**A description of how to configure the modules in the GridVis® software can be found in the online help or the tutorials for the software.**

---

### 8.2.2 Basic device homepage

Another option for **configuring modules or reading out measured values** is available via the device homepage of the basic device.

---

**A description of the device homepage can be found in the user manual for the basic device!**

---

### 8.2.3 Module handling via a user interface (HMI)

As a 3rd option, you can manage, monitor and configure your modules via a web panel (e.g. JPC-100) integrated into your measurement device and module topology as a user interface (HMI) - see Sect. "8.1.1 Connection example 1" on p. 32.

---

**Observe the usage information for your HMI as applicable!**

---

## 9. Operation and button functions of the basic device with module

### 9.1 Operation and button functions of the basic device with 800-CT24 module

The basic device with module has a display and function buttons to enable installation, commissioning and configuration without a PC.

#### **i** INFORMATION

- The configuration of your module and the display of module-relevant measurement data is carried out via the basic device.
- For details and information on the display and button functions of the basic device, refer to the usage information of the basic device.
- The **GridVis®** network analysis software is available at [www.janitza.com](http://www.janitza.com) and can be used to configure your basic device with modules and read out data for analysis (prerequisite: PC connection to your basic device).

### 9.2 Module-relevant menu items of the basic device with 3 modules of the type 800-CT24

This topology example shows the JanBus communication between the UMG 801 basic device, representing other basic devices, and 3 modules of the type 800-CT24 via the 800-CON RJ45 module and an RJ45 cable.

#### **i** INFORMATION

- The following menu items show the module-relevant display entries using the UMG 801 basic device for the topology example below.
- Suitable basic devices and their number of module slots can be found in Sect. "Tab. Suitable basic devices" on p. 2.
- Please note that the names of the 800-CT24 modules on the display of the basic device may differ! You must configure the names of your modules in the GridVis® network analysis software.
- To detect added or removed modules on the basic device, restart the basic device and the GridVis® software. Note in this regard Sect. "7.4 Module identification / Diagnostics on the basic device" on p. 28.

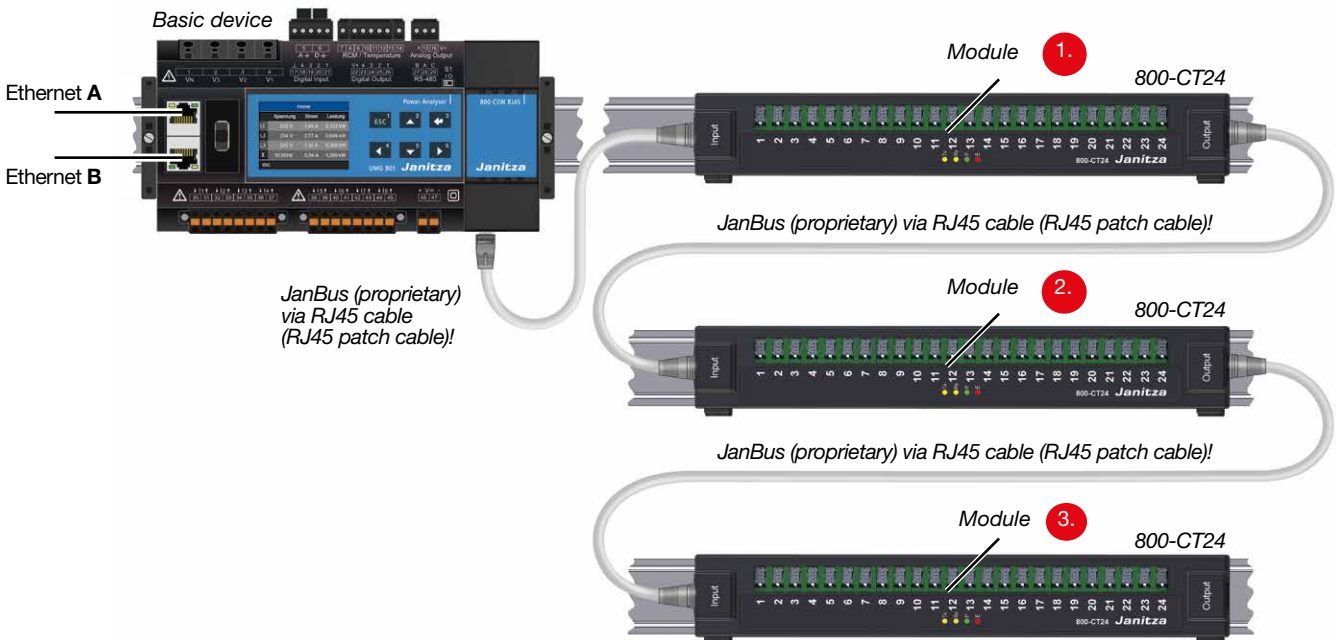

Menu

Home (start screen of the basic device, 1st measuring display)

Phasor diagram

- Basic device 1-4
- Basic device 5-8
- 1. 800-CT24 1-4
- ....
- ...
- 1. 800-CT24 21-24
- 2. 800-CT24 1-4
- ....
- ...
- 2. 800-CT24 21-24
- 3. 800-CT24 1-4
- ....
- ...
- 3. 800-CT24 21-24

Voltage

- LN
- LL
- THD U

Current

- Current
  - Basic device 1-4
  - Basic device 5-8
  - 1. 800-CT24 1-4
  - ....
  - ...
  - 1. 800-CT24 21-24
  - 2. 800-CT24 1-4
  - ....
  - ...
  - 2. 800-CT24 21-24
  - 3. 800-CT24 1-4
  - ....
  - ...
  - 3. 800-CT24 21-24
- THD-I
  - Basic device 1-4
  - Basic device 5-8
  - 1. 800-CT24 1-4
  - ....
  - ...
  - 1. 800-CT24 21-24
  - 2. 800-CT24 1-4
  - ....
  - ...
  - 2. 800-CT24 21-24
  - 3. 800-CT24 1-4
  - ....
  - ...
  - 3. 800-CT24 21-24

Power

Power summary

- Basic device 1-4
- Basic device 5-8
- 1. 800-CT24 1-4
- ....
- ...
- 1. 800-CT24 21-24
- 2. 800-CT24 1-4
- ....
- ...
- 2. 800-CT24 21-24
- 3. 800-CT24 1-4
- ....
- ...
- 3. 800-CT24 21-24

Active power

- Basic device 1-4
- Basic device 5-8
- 1. 800-CT24 1-4
- ....
- ...
- 1. 800-CT24 21-24
- 2. 800-CT24 1-4
- ....
- ...
- 2. 800-CT24 21-24
- 3. 800-CT24 1-4
- ....
- ...
- 3. 800-CT24 21-24

Reactive power

- Basic device 1-4
- Basic device 5-8
- 1. 800-CT24 1-4
- ....
- ...
- 1. 800-CT24 21-24
- 2. 800-CT24 1-4
- ....
- ...
- 2. 800-CT24 21-24
- 3. 800-CT24 1-4
- ....
- ...
- 3. 800-CT24 21-24

Apparent power

- Basic device 1-4
- Basic device 5-8
- 1. 800-CT24 1-4
- ....
- ...
- 1. 800-CT24 21-24
- 2. 800-CT24 1-4
- ....
- ...
- 2. 800-CT24 21-24
- 3. 800-CT24 1-4
- ....
- ...
- 3. 800-CT24 21-24

- Power factor
  - Basic device 1-4
  - Basic device 5-8
  - 1. 800-CT24 1-4
  - .... ..
  - 1. 800-CT24 21-24
  - 2. 800-CT24 1-4
  - .... ..
  - 2. 800-CT24 21-24
  - 3. 800-CT24 1-4
  - .... ..
  - 3. 800-CT24 21-24

**Energy**

- Active energy
  - Basic device 1-4
  - Basic device 5-8
  - 1. 800-CT24 1-4
  - .... ..
  - 1. 800-CT24 21-24
  - 2. 800-CT24 1-4
  - .... ..
  - 2. 800-CT24 21-24
  - 3. 800-CT24 1-4
  - .... ..
  - 3. 800-CT24 21-24
- Reactive energy
  - Basic device 1-4
  - Basic device 5-8
  - 1. 800-CT24 1-4
  - .... ..
  - 1. 800-CT24 21-24
  - 2. 800-CT24 1-4
  - .... ..
  - 2. 800-CT24 21-24
  - 3. 800-CT24 1-4
  - .... ..
  - 3. 800-CT24 21-24
- Apparent energy
  - Basic device 1-4
  - Basic device 5-8
  - 1. 800-CT24 1-4
  - .... ..
  - 1. 800-CT24 21-24
  - 2. 800-CT24 1-4
  - .... ..
  - 2. 800-CT24 21-24
  - 3. 800-CT24 1-4
  - .... ..
  - 3. 800-CT24 21-24

**Drag indicator**

- Basic device 1-4
- Basic device 5-8

**Multifunction channels**

- Current measurement
- Temperature
- RCM overview
- RCM bar charts
- History, res. current

**Digital I/O status**

- Basic device
- Digital I/O status, modules

**Configuration**

- Ethernet config. A
  - IP configuration
  - IP address
  - Netmask
  - Gateway
- Ethernet config. B
  - IP configuration
  - IP address
  - Netmask
  - Gateway
- Fieldbus
  - Device address
  - Baud rate
  - Data frame
- Current transformer
  - Device
    - Basic device 1..4 prim./sec.
    - Basic device 5..8 prim./sec.
    - 1. 800-CT24 1-4
    - .... ..
    - 1. 800-CT24 21-24
    - 2. 800-CT24 1-4
    - .... ..
    - 2. 800-CT24 21-24
    - 3. 800-CT24 1-4
    - .... ..
    - 3. 800-CT24 21-24
- Voltage transformer
  - Voltage transformer 1..4
- Temperature
  - Sensor type
  - Unit
  - Temperature offset

- Display
  - Language
  - Standby after
  - Brightness
- System
  - PIN
  - Restart
  - Time
  - Date
- Reset
  - Standard factory settings
  - Configuration
  - Min/max values
  - Energy
  - Historical data

**Diagnostics**

- Identify all modules
  - **Duration**
  - **Confirm**
- Identify one module
  - **Module position**
  - **Duration**
  - **Confirm**

**System Information**

- Basic device
  - Serial number
  - MAC
  - IP address
  - Date
  - HW version
  - SW version
  - SW build

**1. 800-CT24**

- **Type**
- **Serial number**
- **Position**
- **HW version**
- **SW version**
- **SW build**

**2. 800-CT24**

- **Type**
- **Serial number**
- **Position**
- **HW version**
- **SW version**
- **SW build**

**3. 800-CT24**

- **Type**
- **Serial number**
- **Position**
- **HW version**
- **SW version**
- **SW build**

## 10. Module-relevant configurations

### 10.1 LP current transformer configuration on the basic device

In this user manual, the term "**current transformer**" is used for special transformers for the proportional conversion of currents of large amperages to directly measurable, smaller **current values**. In contrast, the term "**LP current transformer**" is used for special transformers for the proportional conversion of currents of large amperage to directly measurable, smaller **voltage values** (800-CT24 modules).

Current transformers and current sensors provide a safe galvanic isolation between the primary circuit and the measurement circuit due to their constructive design and their physical operating principle.

For simplification, basic devices use only the term "current transformer" in the display for the configuration of both "current transformers" and "LP current transformers".

#### **i** INFORMATION

- Before configuring the LP current transformer ratios, be certain to connect the transformers in compliance with the specifications on the device rating plate and the technical data!
- The displays of the basic device shown below may differ from the actual state!
- Press function button 1 *ESC* to open the menu.
- Use buttons 2 "▲" and 5 "▼" to select the menu item *Configuration* and confirm with button 3 *Enter*.
- The *Configuration* window appears.
- In the *Configuration* window, use buttons 2 "▲" and 5 "▼" to select the menu item *Current transformers* and confirm with button 3 *Enter*.

Configuration	
Ethernet config. A	
Ethernet config. B	
Fieldbus	
<b>Current transformer</b>	
Voltage transformer	
ESC	▼ ▲

Fig. Window Configuration -> item Current transformer

- The *Current transformers* window appears.

Current transformer		
Device	1. 800 CT24	
	Primary	Secondary
Transformer 1..4	5 A	333 mV
Transformer 5..8	5 A	333 mV
ESC	◀ ▶	↵

Fig. Current transformer 1 window. Module 800-CT24 -> Device entry

- In the *Current transformers* window under *Device*, choose the item *Basic device* and confirm with button 3 *Enter*.
- The item *Basic device* appears marked in "blue."
- Use buttons 2 "▲" and 5 "▼" to select the item for the connected module *1st CT24 module* (e.g. for the *1st 800-CT24 current measuring module of your measurement device and module topology*) and confirm the selection with button 3 *Enter*.
- Use button 5 "▼" to go to the setting for the primary side of the LP current transformers 1-4 of the module (current measurement inputs I1..I4).
- The item for the primary side of the LP current transformers I1..I4 appears marked in "blue."
- Press button 3 *Enter*.
- The item for the primary side of the LP current transformers I1..I4 "blinks".
- Use buttons 4 (◀) and 6 (▶) to change the position of the digit to be set and buttons 2 (▲) and 5 (▼) to change the digit (-1/+1).
- Confirm your entries with button 3 *Enter* or end the action by pressing button 1 *ESC*.

Current transformer		
Device	1. 800 CT24	
	Primary	Secondary
Transformer 1..4	<b>5 A</b>	333 mV
Transformer 5..8	5 A	333 mV
ESC	◀ ▶	↵

Fig. Current transformer window - 1st 800-CT24 module -> Primary entry for LP current transformers 1..4.

- Use button 6 (▶) to go to the configuration of the secondary side of the LP current transformers I1..I4 of the module.

- Configure the secondary side of the current transformers I1..I4 of the module in the same way (note here the "nominal voltage in mV" for the LP current transformers).
- Confirm your entries with button 3 *Enter* or end the action by pressing button 1 *ESC*.
- The other **LP current transformer ratios 5-8 (I5..I8) to 21-24 (I21..I24)** of the respective primary and secondary side can be configured using the function buttons as described above.
- You can return to the menu by confirming your entries with button 3 *Enter*, or end this operation with button 1 *ESC*.

## 10.2 LP current transformer configuration in the GridVis® software:

A wizard in the GridVis® network analysis software helps with all module-relevant settings. Also note the usage information of the basic device.

### **i** INFORMATION

You can also configure current and voltage transformer ratios in the device configuration of the **GridVis® software** (see Fig. below). A description of the configuration can be found in the online help or in the tutorials for the software.

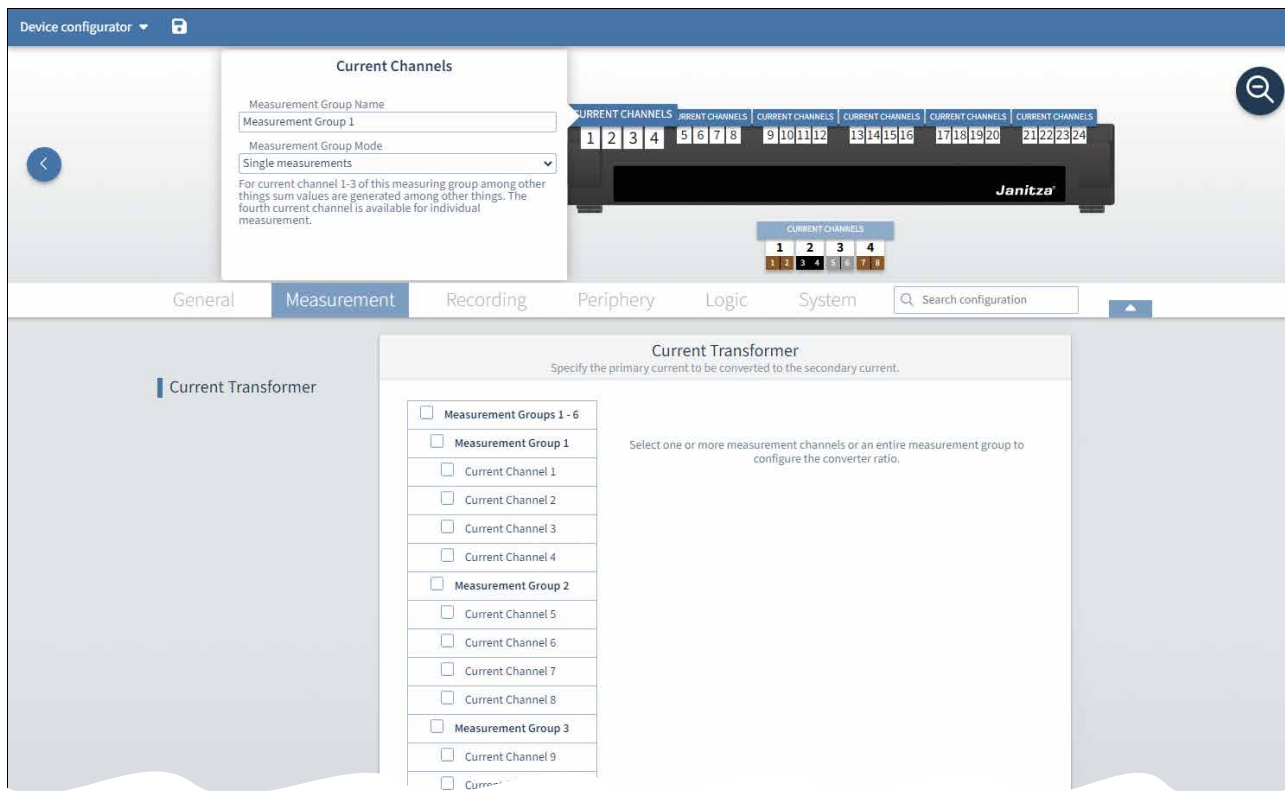

Fig. Current transformer configuration "1st CT24 module" (800-CT24) in the GridVis® software.

### 10.3 LP current transformer configuration via the device homepage of the basic device

Another option to configure the LP current transformers on the module is via the device homepage of the basic device.

#### **i** INFORMATION

A detailed description of the device homepage can be found in the basic device user manual.

The screenshot shows the Janitza device configuration interface. The top navigation bar includes 'Measurement values', 'Settings' (highlighted with a red box), and 'Information'. The 'Settings' menu is expanded, showing 'Current transformer and nominal values' (highlighted in blue). Below this, a dropdown menu shows '1. Modul 800-CT24' (highlighted in a red box). The configuration table for Channel 1-4 and Channel 5-8 is displayed below.

Channel 1 - 4				
Channel	Nominal value	Primary	Secondary	
1	5.000	5.000	0.333	<input type="checkbox"/> Apply to module
2	5.000	5.000	0.333	
3	5.000	5.000	0.333	
4	5.000	5.000	0.333	

Channel 5 - 8				
Channel	Nominal value	Primary	Secondary	
5	5.000	5.000	0.333	
6	5.000	5.000	0.333	

Fig. LP current transformer configuration "Module 1" (800-CT24) on the device homepage of the basic device.



## 11. Module-relevant measuring displays of the basic device with 3 modules of the type 800-CT24

### **i** INFORMATION

- The following measured value and device displays of the basic device refer to the measurement device and module topology described in Sect. 9.2 on page 36.
- The displays may vary depending on the type of basic device and the measuring environment!
- You can change the names of the basic device, the modules or the measurement groups shown in the measurement device display using the device configuration of the GridVis® software.
- The measurement device display shows the measurement group names with the respective position number of the module.
- Depending on the text length, measurement group names appear as scrolling text in the title line of the measurement device display.
- Further measured value and device displays can be found in the usage information for the basic device.

Menu (phasor diagram)

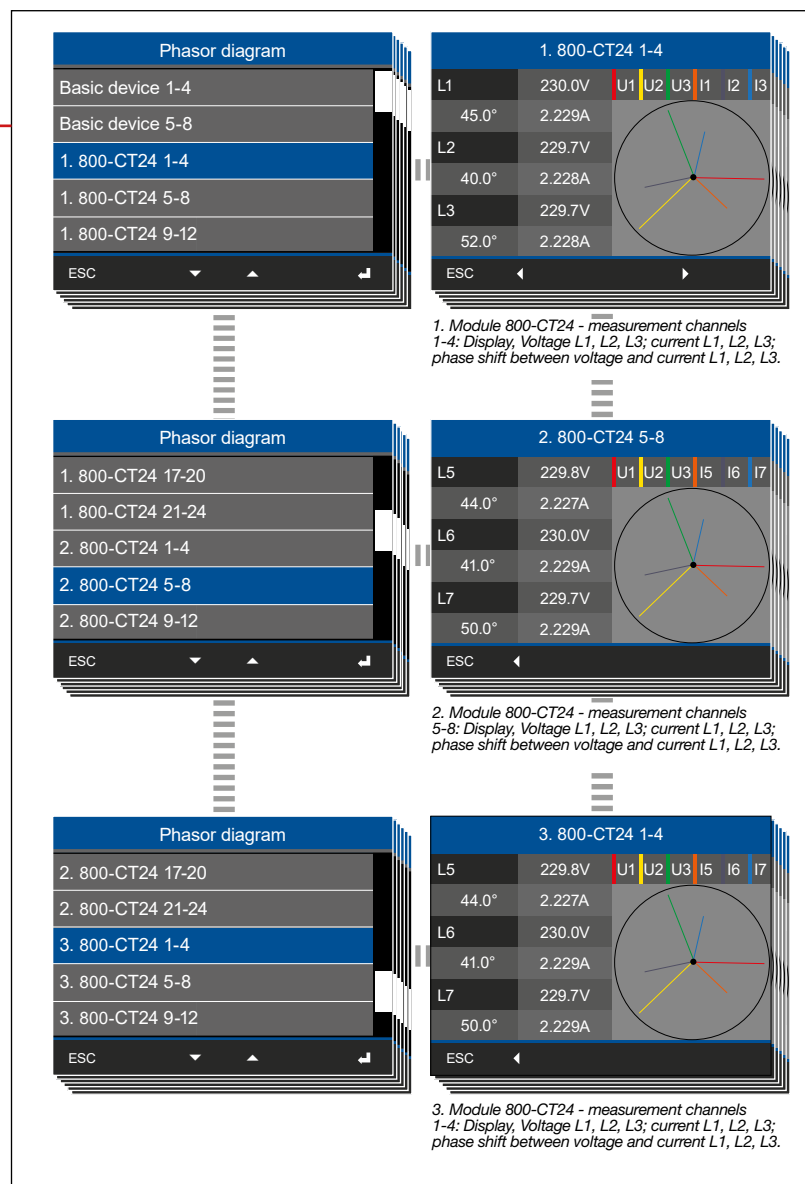
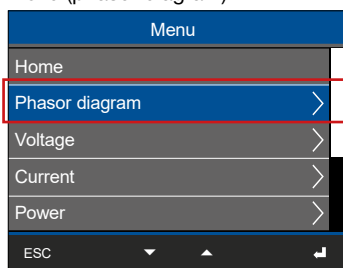

Menu (Current)

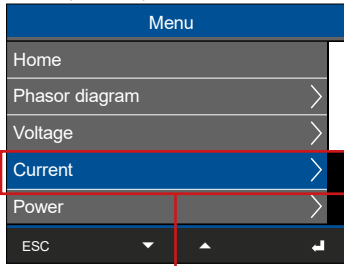

Submenu (Current)

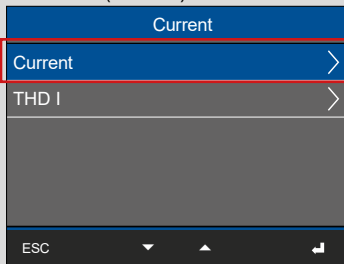

Submenu (THD-I)

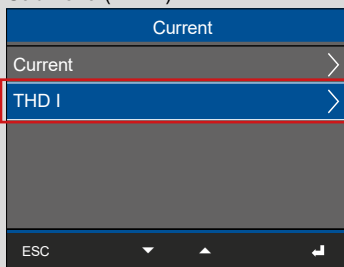

Current

- Basic device 1-4
- Basic device 5-8
- 1. 800-CT24 1-4
- 1. 800-CT24 5-8
- 1. 800-CT24 9-12

ESC

Current 1. 800-CT24 1-4			
	Value	Avg.	Max.
1	1.940A	1.940A	1.940A
2	1.940A	1.940A	1.940A
3	1.940A	1.940A	1.940A
4	0.001A	0.001A	0.001A

ESC

*Display, Current of module #1 800-CT24, measurement channels 1-4 with average and maximum values.*

Current

- 2. 800-CT24 17-20
- 2. 800-CT24 21-24
- 3. 800-CT24 1-4
- 3. 800-CT24 5-8
- 3. 800-CT24 9-12

ESC

Current 3. 800-CT24 5-8			
	Value	Avg.	Max.
5	1.930A	1.930A	1.930A
6	1.930A	1.930A	1.930A
7	1.930A	1.930A	1.930A
8	0.001A	0.001A	0.001A

ESC

*Display, Current of module #3 800-CT24, measurement channels 5-8 with average and maximum values.*

THD-I

- Basic device 1-4
- Basic device 5-8
- 1. 800-CT24 1-4
- 1. 800-CT24 5-8
- 1. 800-CT24 9-12

ESC

THD I 1. 800-CT24 1-4			
	Value	Avg.	Max.
1	166.3%	166.3%	166.3%
2	166.4%	166.4%	166.4%
3	166.4%	166.4%	166.4%
4	201.1%	207.0%	222.2%

ESC

*Display, THD-I of module #1 800-CT24, measurement channels 1-4 - (Total Harmonic Distortion - of the current in %) with average and maximum values.*

THD-I

- 2. 800-CT24 17-20
- 2. 800-CT24 21-24
- 3. 800-CT24 1-4
- 3. 800-CT24 5-8
- 3. 800-CT24 9-12

ESC

THD I 3. 800-CT24 5-8			
	Value	Avg.	Max.
5	166.3%	166.3%	166.3%
6	166.4%	166.4%	166.4%
7	166.4%	166.4%	166.4%
8	209.3%	212.3%	227.6%

ESC

*Display, THD-I of module #3 800-CT24, measurement channels 5-8 - (Total Harmonic Distortion - of the current in %) with average and maximum values.*

Menu (Power)

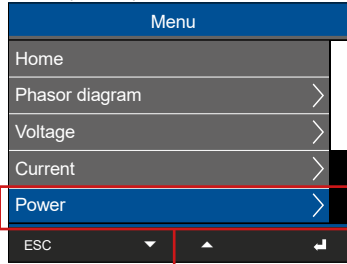

Submenu (Power summary)

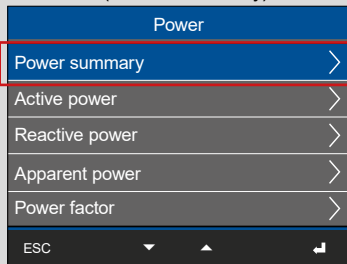

**Power summary**

- Basic device 1-4
- Basic device 5-8
- 1. 800-CT24 1-4**
- 1. 800-CT24 5-8
- 1. 800-CT24 9-12
- ESC

	P	Q	S
1	0.10kW	-0.00kvar	0.19kVA
2	0.10kW	-0.00kvar	0.19kVA
3	0.10kW	-0.00kvar	0.19kVA
4	0.31kW	-0.00kvar	0.58kVA

ESC

*Display, Power summary (active, reactive and apparent power) of module #1 800-CT24, measurement channels 1-4.*

**Power summary**

- 2. 800-CT24 17-20
- 2. 800-CT24 21-24
- 3. 800-CT24 1-4
- 3. 800-CT24 5-8**
- 3. 800-CT24 9-12
- ESC

	P	Q	S
5	0.11kW	-0.00kvar	0.20kVA
6	0.11kW	-0.00kvar	0.20kVA
7	0.11kW	-0.00kvar	0.20kVA
8	0.34kW	-0.00kvar	0.61kVA

ESC

*Display, Power summary (active, reactive and apparent power) of module #3 800-CT24, measurement channels 5-8.*

Submenu (Active power)

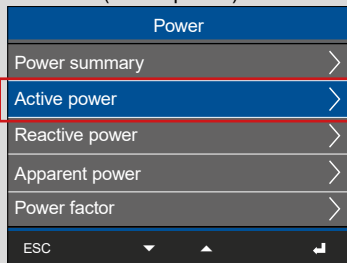

**Active power**

- Basic device 1-4
- Basic device 5-8
- 1. 800-CT24 1-4**
- 1. 800-CT24 5-8
- 1. 800-CT24 9-12
- ESC

	Value	Avg.
1	0.10kW	0.10kW
2	0.10kW	0.10kW
3	0.10kW	0.10kW
4	0.31kW	0.31kW

ESC

*Display, Active power of module #1 800-CT24, measurement channels 1-4 - average values.*

**Active power**

- 2. 800-CT24 17-20
- 2. 800-CT24 21-24
- 3. 800-CT24 1-4
- 3. 800-CT24 5-8**
- 3. 800-CT24 9-12
- ESC

	Value	Avg.
5	0.11kW	0.11kW
6	0.11kW	0.11kW
7	0.11kW	0.11kW
8	0.34kW	0.34kW

ESC

*Display, Active power of module #3 800-CT24, measurement channels 5-8 - average values.*

Submenu (Reactive power)

Power	
Power summary	>
Active power	>
<b>Reactive power</b>	>
Apparent power	>
Power factor	>
ESC	▼ ▲ ↵

Reactive power	
Basic device 1-4	
Basic device 5-8	
<b>1. 800-CT24 1-4</b>	
1. 800-CT24 5-8	
1. 800-CT24 9-12	
ESC	▼ ▲ ↵

Reactive power 1. 800-CT24 1-4		
	Value	Avg.
1	-0.02kvar	-0.01kvar
2	-0.02kvar	-0.01kvar
3	-0.02kvar	-0.01kvar
4	-0.06kvar	-0.02kvar
ESC	◀ ▶ ▼ ▲	

*Display, Reactive power of module #1 800-CT24, measurement channels 1-4 with average values and sums.*

Reactive power	
2. 800-CT24 17-20	
2. 800-CT24 21-24	
3. 800-CT24 1-4	
<b>3. 800-CT24 5-8</b>	
3. 800-CT24 9-12	
ESC	▼ ▲ ↵

Reactive power 3. 800-CT24 5-8		
	Value	Avg.
5	-0.02kvar	-0.01kvar
6	-0.02kvar	-0.01kvar
7	-0.02kvar	-0.01kvar
8	-0.06kvar	-0.03kvar
ESC	◀ ▶ ▼ ▲	

*Display, Reactive power of module #3 800-CT24, measurement channels 5-8 with average values and sums.*

Submenu (Apparent power)

Power	
Power summary	>
Active power	>
Reactive power	>
<b>Apparent power</b>	>
Power factor	>
ESC	▼ ▲ ↵

Apparent power	
Basic device 1-4	
Basic device 5-8	
<b>1. 800-CT24 1-4</b>	
1. 800-CT24 5-8	
1. 800-CT24 9-12	
ESC	▼ ▲ ↵

Apparent power 1. 800-CT24 1-4		
	Value	Avg.
1	0.19kVA	0.16kVA
2	0.19kVA	0.16kVA
3	0.19kVA	0.16kVA
4	0.58kVA	0.48kVA
ESC	◀ ▶ ▼ ▲	

*Display, Apparent power of module #1 800-CT24, measurement channels 1-4 with average values and sums.*

Apparent power	
2. 800-CT24 17-20	
2. 800-CT24 21-24	
3. 800-CT24 1-4	
<b>3. 800-CT24 5-8</b>	
3. 800-CT24 9-12	
ESC	▼ ▲ ↵

Apparent power 3. 800-CT24 5-8		
	Value	Avg.
5	0.20kVA	0.17kVA
6	0.20kVA	0.17kVA
7	0.20kVA	0.17kVA
8	0.61kVA	0.50kVA
ESC	◀ ▶ ▼ ▲	

*Display, Apparent power of module #3 800-CT24, measurement channels 5-8 with average values and sums.*

Submenu (Power factor)

Power	
Power summary	>
Active power	>
Reactive power	>
Apparent power	>
<b>Power factor</b>	>
ESC	▼ ▲ ▾ ▹

Power factor	
Basic device 1-4	
Basic device 5-8	
<b>1. 800-CT24 1-4</b>	
1. 800-CT24 5-8	
1. 800-CT24 9-12	
ESC	▼ ▲ ▾ ▹

Power factor 1. 800-CT24 1-4		
	cos(phi)	Power factor
1	0.984	0.513
2	0.985	0.513
3	0.985	0.513
4	0.985	0.981
ESC	◀ ▼ ▲ ▶	

*Display, Power factor of module #1 800-CT24, measurement channels 1-4 with cos(phi) and sums.*

Power factor	
2. 800-CT24 17-20	
2. 800-CT24 21-24	
3. 800-CT24 1-4	
<b>3. 800-CT24 5-8</b>	
3. 800-CT24 9-12	
ESC	▼ ▲ ▾ ▹

Power factor 3. 800-CT24 5-8		
	cos(phi)	Power factor
5	0.985	0.513
6	0.985	0.513
7	0.985	0.513
8	0.985	0.981
ESC	◀ ▼ ▲ ▶	

*Display, Power factor of module #3 800-CT24, measurement channels 5-8 with cos(phi) and sums.*

Menu (Energy)

Menu	
Power	>
<b>Energy</b>	>
Drag pointer	>
Multifunctional channels	>
Digital I/O-Status	>
ESC	▼ ▲ ▾ ▹

Submenu (Active energy)

Energy	
<b>Active energy</b>	>
Reactive energy	>
Apparent energy	>
ESC	▼ ▲ ▾ ▹

Active energy	
Basic device 1-4	
Basic device 5-8	
<b>1. 800-CT24 1-4</b>	
1. 800-CT24 5-8	
1. 800-CT24 9-12	
ESC	▼ ▲ ▾ ▹

Active energy 1. 800-CT24 1-4		
	Consumed	
1	42.9 kWh	
2	42.9 kWh	
3	42.9 kWh	
4	4.1 kWh	
ESC	◀ ▼ ▲ ▶	

*Display, Consumed active energy of module #1 800-CT24, measurement channels 1-4.*

Active energy	
2. 800-CT24 17-20	
2. 800-CT24 21-24	
3. 800-CT24 1-4	
<b>3. 800-CT24 5-8</b>	
3. 800-CT24 9-12	
ESC	▼ ▲ ▾ ▹

Active energy 3. 800-CT24 5-8		
	Consumed	
5	42.5 kWh	
6	42.5 kWh	
7	42.5 kWh	
8	4.6 kWh	
ESC	◀ ▼ ▲ ▶	

*Display, Consumed active energy of module #3 800-CT24, measurement channels 5-8.*

Submenu (Reactive energy)

Energy	
Active energy	>
<b>Reactive energy</b>	>
Apparent energy	>
ESC	

Reactive energy	
Basic device 1-4	
Basic device 5-8	
<b>1. 800-CT24 1-4</b>	
1. 800-CT24 5-8	
1. 800-CT24 9-12	
ESC	

Reactive energy 1. 800-CT24 1-4	
Inductive	
1	50.2 kvarh
2	50.2 kvarh
3	50.2 kvarh
4	11.2 kvarh
ESC	

*Display, Inductive reactive energy of module #1 800-CT24, measurement channels 1-4.*

Reactive energy	
2. 800-CT24 17-20	
2. 800-CT24 21-24	
3. 800-CT24 1-4	
<b>3. 800-CT24 5-8</b>	
3. 800-CT24 9-12	
ESC	

Reactive energy 3. 800-CT24 5-8	
Inductive	
5	51.2 kvarh
6	51.2 kvarh
7	51.2 kvarh
8	12.2 kvarh
ESC	

*Display, Inductive reactive energy of module #3 800-CT24, measurement channels 5-8.*

Submenu (Apparent energy)

Energy	
Active energy	>
Reactive energy	>
<b>Apparent energy</b>	>
ESC	

Apparent energy	
Basic device 1-4	
Basic device 5-8	
<b>1. 800-CT24 1-4</b>	
1. 800-CT24 5-8	
1. 800-CT24 9-12	
ESC	

Apparent energy 1. 800-CT24 1-4	
Sum	
1	57.2 kVAh
2	57.2 kVAh
3	57.2 kVAh
4	6.9 kVAh
ESC	

*Display, Apparent energy of module #1 800-CT24, measurement channels 1-4.*

Apparent energy	
2. 800-CT24 17-20	
2. 800-CT24 21-24	
3. 800-CT24 1-4	
<b>3. 800-CT24 5-8</b>	
3. 800-CT24 9-12	
ESC	

Apparent energy 3. 800-CT24 5-8	
Sum	
5	56.2 kVAh
6	56.2 kVAh
7	56.2 kVAh
8	5.9 kVAh
ESC	

*Display, Apparent energy of module #3 800-CT24, measurement channels 5-8.*

## Menu (Diagnostics)

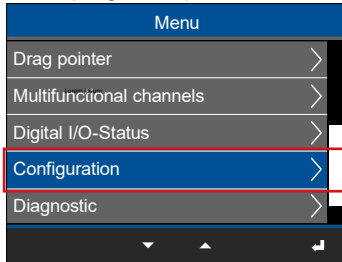
**i INFORMATION**

The descriptions for the "Configuration" menu can be found in Sect. "10. Module-relevant configurations" on p. 40.

## Menu (Diagnostics)

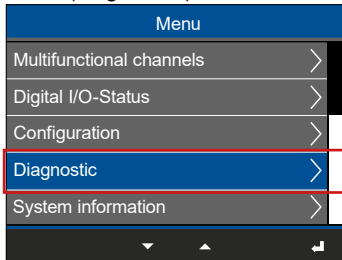
**i INFORMATION**

The descriptions for the "Diagnostics" menu can be found in Sect. "7.4 Module identification / Diagnostics on the basic device" on p. 28.

## Menu (System information)

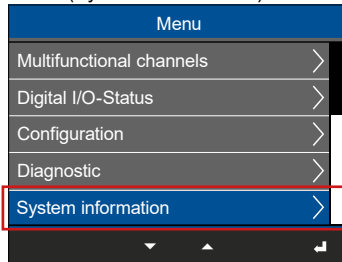
**i INFORMATION**

The descriptions of the "System Information" menu can be found in the Sect. "4.4 System information on the module" on p. 22.



## 12. Device views

- The figures are for illustration purposes only and are not to scale.
- Dimensions in mm (in).

Rear view

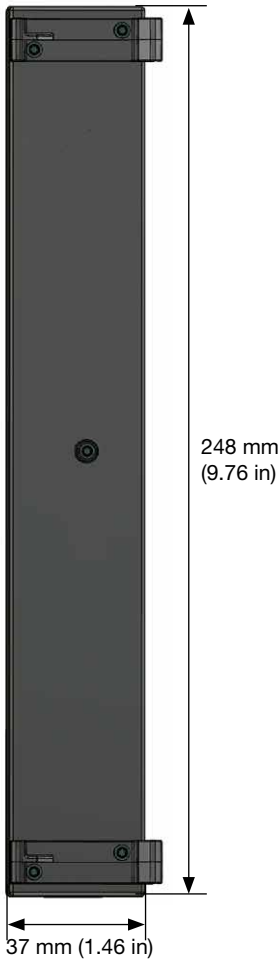

Front view

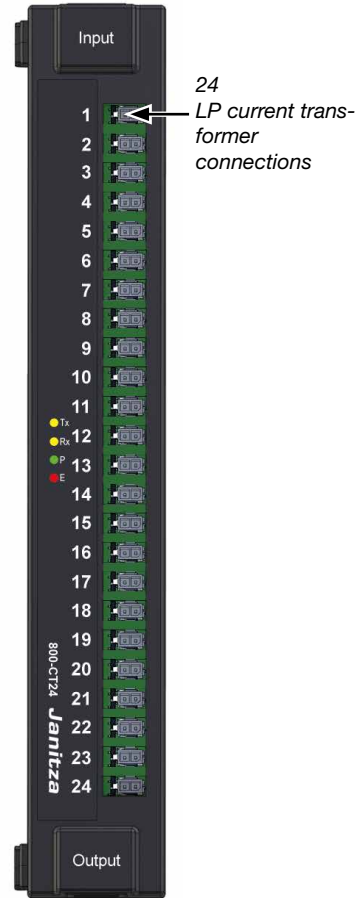

View from left

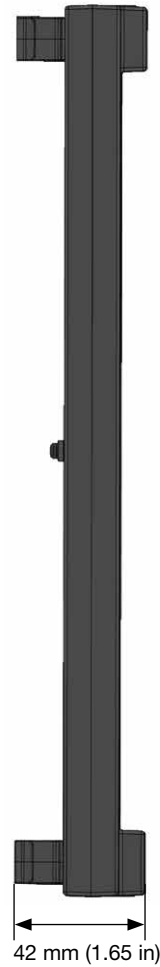

Bottom view

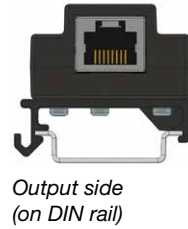

Top view

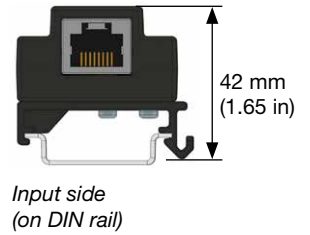

## 13. Technical specifications

### 13.1 Technical data

General	
Net weight	120 g (0.26 lb)
Device dimensions	W = 248 mm (w = 9.76 in), H = 42 mm (h = 1.65 in), D = 37 mm (d = 1.46 in)
Mounting orientation	As desired
Fastening/mounting - Suitable DIN rails (35 mm / 1.38 in)	TS 35/7.5 according to EN 60715 TS 35/10 TS 35/15 x 1.5
Protection against foreign matter and water	IP20 according to EN60529
Impact resistance	IK07 according to IEC 62262

Transport and storage	
The following specifications apply for devices transported and stored in the original packaging.	
Free fall	1 m (39.37 in)
Temperature	K55: -25 °C (-13 °F) to +70 °C (158 °F)
Relative humidity	0 to 95% at 25 °C (77 °F), no condensation

Environmental conditions during operation	
The module · Must only be operated with suitable basic devices (see Sect. "Tab. Suitable basic devices" on p. 2). · Is for weather-protected and stationary use. · Fulfills operating conditions according to DIN IEC 60721-3-3. · Has protection class II according to IEC 60536 (VDE 0106, part 1), a ground wire connection is not required!	
Working temperature	-10 °C (14 °F) .. +55 °C (131 °F)
Relative humidity	5 to 95% at 25 °C (77 °F), no condensation
Pollution degree	2
Ventilation	No forced ventilation required.

Current measurement	
Rated voltage for the LP current transformers	333 mV
Channels	24
Measuring range	0 ... 400 mV
Crest factor	1.8
Overload for 1 s	1 V
Resolution	16 bit
Sampling frequency	6.8 kHz
Frequency of the fundamental oscillation	40 Hz .. 70 Hz
Harmonics	1 .. 15 (odd only)

Interface and energy supply	
RJ45 interface (In/Out)	JanBus (proprietary) via RJ45 cable (RJ45 patch cable).
Supply voltage (via JanBus interface)	24 V
JanBus (proprietary) - Max. bus lengths/cable lengths of the RJ45 cables	Cat 7/7a = 100 m (109.36 yd) (AWG 22: $\varnothing = 0.64$ mm, cross-sectional area = 0.33 mm <sup>2</sup> )
	Cat 6/6a = 75 m (82.02 yd) (AWG 23: $\varnothing = 0.57$ mm, cross-sectional area = 0.26 mm <sup>2</sup> )
	Cat 5/5e = 60 m (65.62 yd) (AWG 24: $\varnothing = 0.51$ mm, cross-sectional area = 0.21 mm <sup>2</sup> )
Current sensor/LP current transformer interface	Micro Mate-N-Lok connector

Module LEDs	
Tx (send data)	Blink "orange" during operation and indicate cyclic data exchange.
Rx (receive data)	
P (power – power supply)	Lights "green" if the supply of power via the JanBus interface is correct.
E (error – initialization and malfunction)	Lights "red" when initializing/starting the device and in the event of a fault.

### 13.2 Performance characteristics of functions (only valid in conjunction with a UMG 801 as the basic device!)

Function	Symbol	Accuracy class 333 mV nominal voltage	Measuring range	Display range
Total active power	P	0.5 (IEC61557-12)	0 .. 12.6 kW	0 .. 999 GW
Total reactive power	QA, Qv	1 (IEC61557-12)	0..16.6 kvar	0 .. 999 Gvar
Total apparent power	SA, Sv	0.5 (IEC61557-12)	0 .. 12.6 kVA	0 .. 999 GVA
Total active energy	Ea	0.5 (IEC61557-12) 0.5S (IEC62053-22)	0 .. 999 GWh	0 .. 999 GWh
Total reactive energy	ErA, ErV	1 (IEC61557-12)	0 .. 999 Gvarh	0 .. 999 Gvarh
Total apparent energy	EapA, EapV	0.5 (IEC61557-12)	0 .. 999 GVAh	0 .. 999 GVAh
Phase current	I	0.5 (IEC61557-12)	0 .. 424 mVrms	0 .. 999 kA
Power factor	PFA, PFV	1 (IEC61557-12)	0.00 .. 1.00	0.00 .. 1.00
Current harmonics	Ih	Cl. 1 (IEC61000-4-7)	1 ... 15 (odd only)	0 A .. 999 kA
THD of the current	THDI	1.0 (IEC61557-12)	0 .. 999%	0 .. 999%

#### INFORMATION

Detailed information on the functions and data of the basic device can be found in the usage information included with the basic device or available for download at [www.janitza.com](http://www.janitza.com)!

## 14. Dismounting

### ATTENTION

**Improper handling or handling them too roughly can destroy your devices, modules and components!**

Contacts, bottom bolts and retaining brackets can be damaged or broken off during mounting or dismantling.

- **Never use force to mount or dismount devices, modules and components! Never tear devices, modules or components off of the DIN rail.**
- **When dismantling devices, modules and components, remove the wiring beforehand (e.g. cables, (LP) current transformers, etc.).**
- **Carefully unlock the bottom bolts and retaining brackets of the devices, modules and components with a screwdriver!**
- **Never touch or manipulate contacts! Protect the contacts during handling, transport and storage!**
- **Observe related usage information on the devices, modules and components!**

### ATTENTION

**Material damage due to disassembly or decoupling of the module during operation!**

Dismounting or decoupling the module during communication with the basic device can cause damage to your devices!

- **Disconnect your system from the power supply prior to dismantling or disconnecting the module! Secure it against being switched back on! Check to be sure it is de-energized! Ground and short circuit! Cover or block off adjacent live parts!**

### **i** INFORMATION

After dismantling the 800-CT24 module, the Grid-Vis® software deactivates the corresponding module! Information on this and further procedures can be found in the online help for the Grid-Vis® software.

1. Disconnect the supply of power to the system before beginning work! Secure it against being switched on! Check to be sure it is de-energized! Ground and short circuit! Cover or block off adjacent live parts!
2. Disconnect the 800-CT24 module from the Jan-Bus topology by removing the RJ45 cable.
3. Disconnect the wiring of your module (remove LP current transformer).
4. Unlock all bottom bolts of your module  
**Recommendation:** Use a screwdriver (be careful!).
5. Remove your module from the DIN rail.

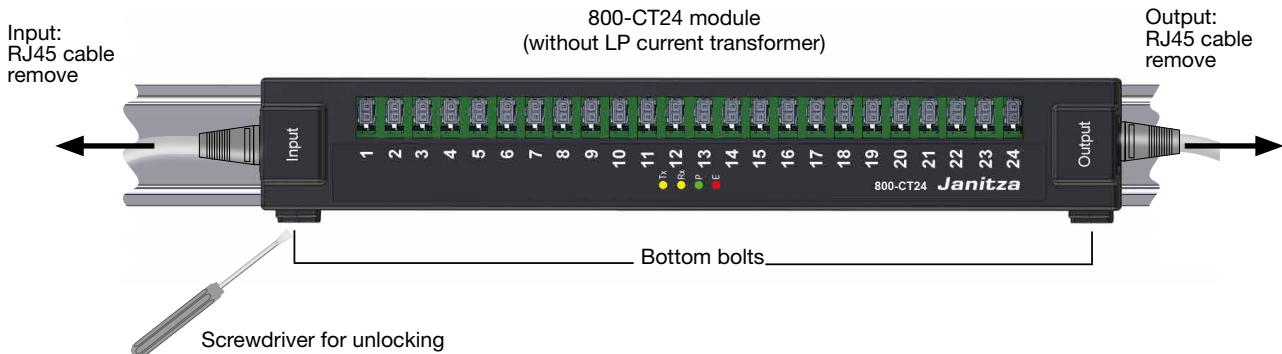

Fig. Dismounting the 800-CT24 module

## 15. Module exchange/error cases

Before replacing a module, please refer to Sect. "14. Dismounting" on p. 55 and "4. Mounting" on p. 18.

### ATTENTION

**Handling your module too roughly may cause damage to the module and result in material damage!**

The bottom bolts and the bus connector contacts can be damaged or broken off when dismantling your module.

- **Never pull the module out of the DIN rail forcefully.**
- **Remove the module from the DIN rail without touching or damaging the bus connector contacts.**
- **First remove the connection terminals with the wiring of the digital inputs and then carefully unlock the bottom bolts of the module with a screwdriver!**

### ATTENTION

**Material damage due to disassembly or decoupling of the modules during operation!**

Dismounting or decoupling the modules during communication with the basic device can cause damage to your devices!

- **Disconnect your system from the power supply prior to dismantling or decoupling the modules! Secure it against being switched back on! Check to be sure it is de-energized! Ground and short circuit! Cover or block off adjacent live parts!**

### INFORMATION

**Observe the following:**

**After dismantling modules, the GridVis® software deactivates the corresponding module!** Information on this and further procedures can be found in the online help for the GridVis® software.

### 15.1 Module replacement

A module must be exchanged, for example to replace a defective module with an intact module in your meter and module topology. The module replacement is carried out in the GridVis® software.

**On the basic device**, you can recognize a defective module of your measurement device and module topology in the "Configuration" display. The defective module is **missing** in the "Configuration" display.

To exchange a module, proceed as follows:

1. Proceed with a module exchange as described in p. 55 and Sect. "4. Mounting" on p. 18.
2. Replace a defective module with an intact one, for example.
3. Supply your meter and module topology (your system) with voltage.
4. Use the GridVis® software ("Module exchange" function) to transfer data from a defective module to the intact module.

### INFORMATION

Please note before replacing a module! The "Module exchange" function in the GridVis® software overwrites data records of exchanged modules in the memory of the basic device!

A description of the module exchange in the GridVis® software can be found in the online help or the tutorials for the software.

## 15.2 Modules - Error cases

As already described in Sect. "7.4.3 Module identification - LED blink interval" on p. 30, the module has 4 LEDs.

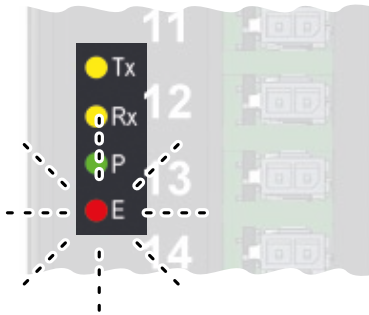

Fig.: LED status in the event of an error

In the event of an error, the red LED (E) of the relevant module blinks during operation at an interval of **0.5 s**.

After the definition of the error state there is a pause of **2 s** and the blink interval starts again from the beginning (repetition loop).

The number of blinks indicates the following error states:

Number of blinks	Error state
0	No error - normal operation.
1	Waiting for termination of the start pulse for the termination.
2	Waiting for response of the following module.
3	Waiting for start of addressing pulse
4	Waiting for the end of the addressing pulse.
5	Termination failed.
10	Application could not be started, module is still in the bootloader.

Tab.: Number of blinks / error status

### Proceed as follows in the event of a module error:

1. Restart your meter and module topology (basic device: Menu > Configuration > System > Restart).
2. Check the connections and the fit of the devices, modules and components of your meter and module topology while complying with the safety rules!

### **⚠ WARNING**

**Risk of injury due to electrical current and voltage!** Severe bodily injury or death can result! Therefore please abide by the following:

- **Do not touch bare, stripped wires or device inputs that are dangerous to touch on the devices, components and modules.**
- **Switch off your installation before commencing work! Secure it against being switched on! Check to be sure it is de-energized! Ground and short circuit! Cover or block off adjacent live parts!**

3. If these measures are unsuccessful, please contact our support team ([www.janitza.com](http://www.janitza.com))!

## 16. Service and maintenance

Your measurement device (module/component) goes through various safety tests and is marked with a seal before delivery. If a measurement device (module/component) is opened, the safety tests must be repeated. A warranty is only assumed for unopened measurement devices (modules/components).

### 16.1 Repair

Repairs can only be carried out by the manufacturer.

### 16.2 Service

If questions arise which are not described in this user manual, please contact the manufacturer.

To answer your questions, it is essential that you provide the following information:

- Device designation (see rating plate).
- Serial number (see rating plate).
- Hardware version (see system display).
- Software release (see system display).
- Measured voltage and supply voltage.
- Error description.

### 16.3 Device adjustment

Devices (components/modules) are adjusted by the manufacturer prior to outbound delivery. No readjustment is required when the environmental conditions are complied with.

### 16.4 Calibration interval

A recalibration is recommended after about 5 years. Contact the manufacturer or an accredited laboratory for calibration.

### 16.5 Firmware update

A firmware update of the basic device and the module works as follows:

1. Via the device homepage of the basic device (menu "Settings -> Firmware update" - see usage information for the basic device).
2. Via the firmware update wizard of the GridVis® software:
  - Open the Firmware Update Assistant in the GridVis® software by clicking "Update device" in the "Extras" menu.
  - Select a corresponding update file and carry out the update.

### **i** INFORMATION

This user manual describes the modules and provides information on the operation of the modules via the basic device.

In addition to this user manual, refer to the usage information for your basic device, such as:

- User manual
- Installation manual
- Safety information
- Data sheet
- Installation supplement

In addition, also note any special usage information for your application/project!

Moreover, the GridVis® software has an "online help" feature.

### 16.6 Procedure in the event of a malfunction

#### **ATTENTION**

**An error in the communication with the basic device leads to a device fault!**

If communication from the basic device to the modules is lacking or faulty during operation, a warning signal will appear on the display of the basic device.

**Prior to dismounting or disconnecting the modules of the basic device (the system)**

- **Disconnect the supply of power! Secure it against being switched on! Check to be sure it is de-energized! Ground and short circuit! Cover or block off adjacent live parts!**
- **Prior to remounting, it may be necessary to restart the basic device.**
- **Also take note of the chapter "Procedure in the event of a malfunction" in the documentation of your basic device.**
- **If the measures indicated here are unsuccessful, please contact our support team ([www.janitza.com](http://www.janitza.com)).**
- **If there is discernible damage, send the meter, module or component back to the manufacturer in compliance with proper transport conditions.**

### 16.7 Reset to factory settings

The "Reset to factory settings" function must be carried out via the basic device. A description of this can be found in the user manual for the basic device.

### 16.8 Information on saving measured values and configuration data

---

#### **INFORMATION**

The basic device stores the following measured values every 5 minutes at the latest:

- Min. / max. / average values
- Energy values (work values)

The basic device saves configuration data immediately!

---

Janitza electronics GmbH  
Vor dem Polstück 6  
35633 Lahnau / Germany

Support tel. +49 6441 9642-22  
Email: [info@janitza.com](mailto:info@janitza.com)  
[www.janitza.com](http://www.janitza.com)

**Janitza<sup>®</sup>**