



Product may differ from images

- EN** The full operating instructions can be found at:
- DE** Die vollständige Bedienungsanleitung finden Sie unter:
- FR** Le mode d'emploi complet est disponible sur:
- ES** Las instrucciones de funcionamiento completas se pueden encontrar en:
- IT** Le istruzioni per l'uso complete sono disponibili all'indirizzo:

[www.idemsafety.com](http://www.idemsafety.com)

**Description**

UGB-NET-CS is an access gate box which combines solenoid locking, RFID coded sensor and integrated machine control functions in a robust heavy-duty housing. Available in Die - Cast Metal (red) or Stainless Steel 316.

Integrated safety protocols for use with industry recognised Industrial Ethernet network protocols.

highly customisable, up to 6 illuminated pilot devices (Push buttons, lamps, selector switches and e-stops) to be selected for the device lid.

Cat. 4/PL e Guard interlocking, lock monitoring and E-Stop, approved by cULus and TUV to the latest international safety standards.

All external mounting holes and pluggable connectors make it quick and easy to install. No need to remove the lid during installation.

**Features**

- Integrated EtherNet/IP with CIP Safety.
- Robust die-cast or stainless steel 316 housing materials.
- Device lid customisable with selection of pilot devices.
- Cat. 4/PL e Guard interlocking, lock monitoring and E-Stop.
- Individual RFID actuator coding.
- Actuator holding force up to 3000N.
- Handles, rear release, and mounting plate accessories.
- Simple and quick installation.

Technical Specifications	
<b>Safety</b>	
Standards	ISO 13849-1, IEC 62061, IEC 61508, IEC 60947-5-3, ISO 14119
Safety functions	<b>Guard interlocking</b> Complies with the requirements of IEC 60947-5-3. Classified as a type 4 device with high coding acc. to ISO 14119.
	<b>Guard locking</b> With lock monitoring for person and process protection.
	<b>Emergency stop</b>
Certifications	CE, TUV, cULus
<b>Safety Data</b>	
Category	4
Performance Level	e
MTTFd	High
DC	99%
Mission Time	20 years
PFHd (Guard Locking, Lock Monitoring)	$7.3 \times 10^{-10}$ (0.7 % of SIL 3)
PFHd (Emergency Stop)	$2.3 \times 10^{-9}$ (2.3 % of SIL 3)
<b>Power Supply</b>	
Operating voltage	24 V DC +10%/-15% SELV/PELV acc. to IEC 61131-2 UL – Class 2 Power Supply Functional Earth must be connected.
Current – Normal Operation	200 mA
Current – Peak	650 mA
<b>Device Characteristics</b>	
Actuator coding level	Type 4 (RFID), High
Assured operating (Sao)	10mm
Assured release (Sar)	20mm
Assured locking distance	5mm
Response time (E-Stop)	36ms max. (E-Stop -> field bus)
Response time (Guard Interlock)	36ms max. (Guard/Lock -> field bus)
<b>Mechanical Data</b>	
Maximum holding force (F1)	3000 N
Rated holding force (Fzh)	2307 N
<b>Environmental Data</b>	
Storage Temperature	-30°C to 85°C
Operating temperature	-5°C to 40°C
Enclosure Protection	IP 65
Maximum operating altitude	2000m



Configuration Specific Datasheet

RFID Guard Interlock with Integrated EtherNet/IP with CIP Safety

DIP Switch

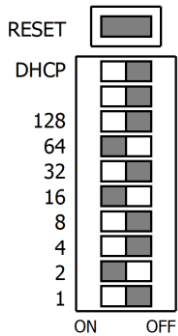
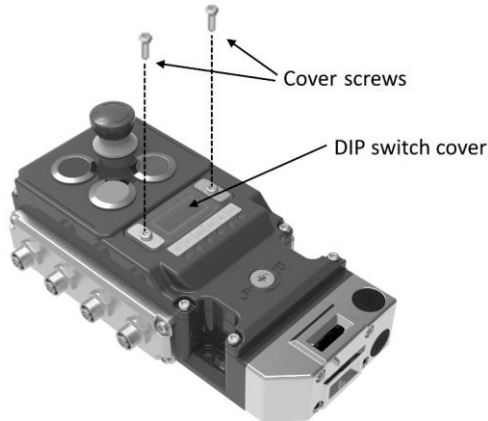

Out of the box the DIP switches are all set to the OFF position, if left unchanged the device will enter DHCP mode once powered and connected to the network.

To manually set an IP address use DIP switches 1..8 (binary format). The default subnet is 192.168.1.xxx.

If changes are applied while the device is powered, press and hold the reset button or cycle power for the changes to take effect.

Indication

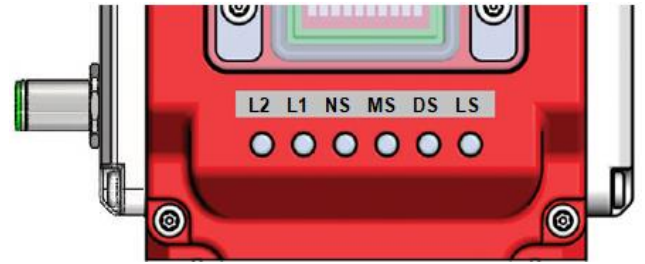

LED	Function	Colour
LS	Locking Switch Status	Red/Green
DS	Device Status	Red/Green
MS	Module Status	Red/Green
NS	Network Status	Red/Green
L1	Link 1	Amber/Green
L2	Link 2	Amber/Green

LED	LED State	Comment
LS	Off	Locking switch inactive, waiting for data connection
	Green	Guard is closed and locked
	Green flash	Guard is closed and unlocked
	Red	Internal fault detected, reset required
	Red flash	Missing or incorrect RFID tag
	Red double flash	Guard forced open, reset required
	Red/Green alternate	Reset in progress
DS	Green	Device running
	Red	Internal fault detected
MS	Green	Connection to PLC, Run state
	Green Flash	Connection to PLC, Idle state
	Red	Major Fault
	Red Flashing	Recoverable fault, check PLC/UGB-NET configuration
NS	Off	No IP address set
	Green	Online, connection(s) established
	Green flash 1Hz	Online, no connections established
	Red	Network fault
	Red flash	Connection timed out
L1 L2	Off	No Ethernet link detected
	Amber	Ethernet link detected
	Amber flash	Ethernet data transfer

Lid Device Positions

4-Way

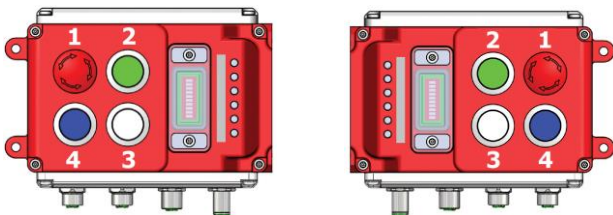

6-Way

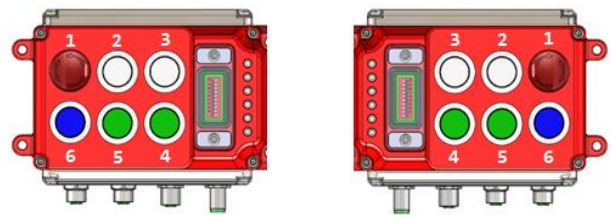

Right

Left



Data Registers – Non-Safe I/O									
BITS -		0	1	2	3	4	5	6	7
INPUTS	BYTE 0	LID DEVICE 1 STATE	LID DEVICE 2 STATE	LID DEVICE 3 STATE	LID DEVICE 4 STATE	LID DEVICE 5 STATE	LID DEVICE 6 STATE	--	--
	BYTE 1	GUARD SWITCH OPEN	--	--	--	--	--	--	--
	BYTE 2	GUARD SWITCH UNLOCKED	--	--	--	--	--	--	--
OUTPUTS	BYTE 0	LID LAMP 1 ENABLE	LID LAMP 2 ENABLE	LID LAMP 3 ENABLE	LID LAMP 4 ENABLE	LID LAMP 5 ENABLE	LID LAMP 6 ENABLE	--	--
	BYTE 1	GUARD SWITCH SOL ENABLE	--	--	--	--	--	--	--
	BYTE 2	GUARD SWITCH RESET	--	--	--	--	--	--	--

Data Registers – Safe I/O									
BITS -		0	1	2	3	4	5	6	7
INPUTS	BYTE 0	GUARD CH1	GUARD CH2	E-STOP CH1	E-STOP CH2	--	--	--	--
	BYTE 1	GUARD QUALIFIER CH1	GUARD QUALIFIER CH2	E-STOP QUALIFIER CH1	E-STOP QUALIFIER CH2	--	--	--	--
	BYTE 2	--							
OUTPUTS	BYTE 0	--							
	BYTE 1	GUARD RESET CH1	GUARD RESET CH2	E-STOP RESET CH1	E-STOP RESET CH2	--	--	--	--
	BYTE 2	--							

**Data Register – Descriptions**

**E-Stop and LID DEVICE 1 STATE**

If the E-Stop is fitted 'LID DEVICE 1 STATE' is inactive.

The E-Stop state is signalled only in the Safe IO bytes.

**Guard Switch Faults and Reset**

If a fault in the guard unlock/opening sequence is detected the guard interlock will require resetting.

The detected fault will be signalled by 'GUARD SWITCH FAULT' bit set. Indication will be shown on the device with a RED double flash (pause, RED, RED) of the 'LS' LED.

To reset the fault, set then clear the 'GUARD SWITCH RESET' bit.

**Safety Qualifier Bits**

The safety qualifier bits (Safe IO, Inputs, Byte 1) should be used in conjunction with the safety state bits (Safe IO, Inputs, Byte 0). The safety state bits are only valid safety signals when the qualifier bits are high.

If the internal electronics detect a fault relating to the safety states, the qualifier bits are set low. To re-enable the qualifier bits the corresponding safety reset bits should be set high (Safe IO, Outputs, Byte 1). Re-check the operation of the safety functions before continuing normal operation.



Connection Parameters						
	Input		Output		Configuration	
	Assembly Instance	Bytes	Assembly Instance	Bytes	Assembly Instance	Bytes
Safety Input	612	3	199	--	832	--
Safety Output	199	--	768	3	--	--
Standard IO	100	3	150	3	5	0



**INFORMATION**

- The device EDS file can be found via the UGB-NET product page of the IDEM website [www.idemsafety.com/products](http://www.idemsafety.com/products) or alternatively please contact [technical@idemsafety.com](mailto:technical@idemsafety.com)

**Troubleshooting**

**Actuator Replacement/Teach in**

**Reset Ownership**

With the UGB-NET is powered and connected to the network:

1. Insert the new or replacement actuator into the head of the switch.
2. Set, then clear standard IO output Byte 2, Bit 0. ('GUARD SWITCH RESET').
3. The 'LS' LED flashes green/red while the guard resets.
4. The 'LS' LED will repeat a red double flash once reset.
5. Repeat steps 2 and 3 until the 'LS' LED is green after reset.
6. The new or replacement actuator is now paired.

Ownership of the device can be reset through RSLogix:

1. Open the properties of the device requiring reset and navigate to the 'Connection' tab.
2. Check 'Inhibit Connection' and click 'Apply'.
3. Navigate to the 'Safety' tab, click 'Reset Ownership' button.
4. When prompted enter the password 'IXXAT\_SafeT100CS' (case sensitive) to initiate the reset.

Ensure correct operation before resuming normal operation.

The device will reset once complete with the Safety Network Number cleared.

**Data and Power Connectors**

Link 1		Link 2		Power		Power	
Female D-Code M12		Female D-Code M12		Female A-Code M12		Male A-Code M12	
1	TX+	1	+24V	1	+24V	1	+24V
2	RX+	2	0V	2	0V	2	0V
3	TX-	3	0V	3	0V	3	0V
4	RX-	4	+24V	4	+24V	4	+24V
				5	Earth	5	Earth
				Pins 1 and 4 internally connected. Pins 2 and 3 internally connected.			
	<b>INFORMATION</b> When multiple devices are used in a daisy-chain arrangement the power bus may be forwarded via the UGB-NET device. Please see technical specification and ensure the total current through each device does not exceed the specified maximum current.						
	<b>INFORMATION</b> Not all connections are required for all applications, the minimum requirement to operate the device is one data connection and one power connection. All 4 ports are utilised when the UGB-NET is used a 'daisy chain' configuration. Unused power and data ports must be sealed using a protective cover with minimum IP65 rating.						



UGB-NET Outline Dimensions

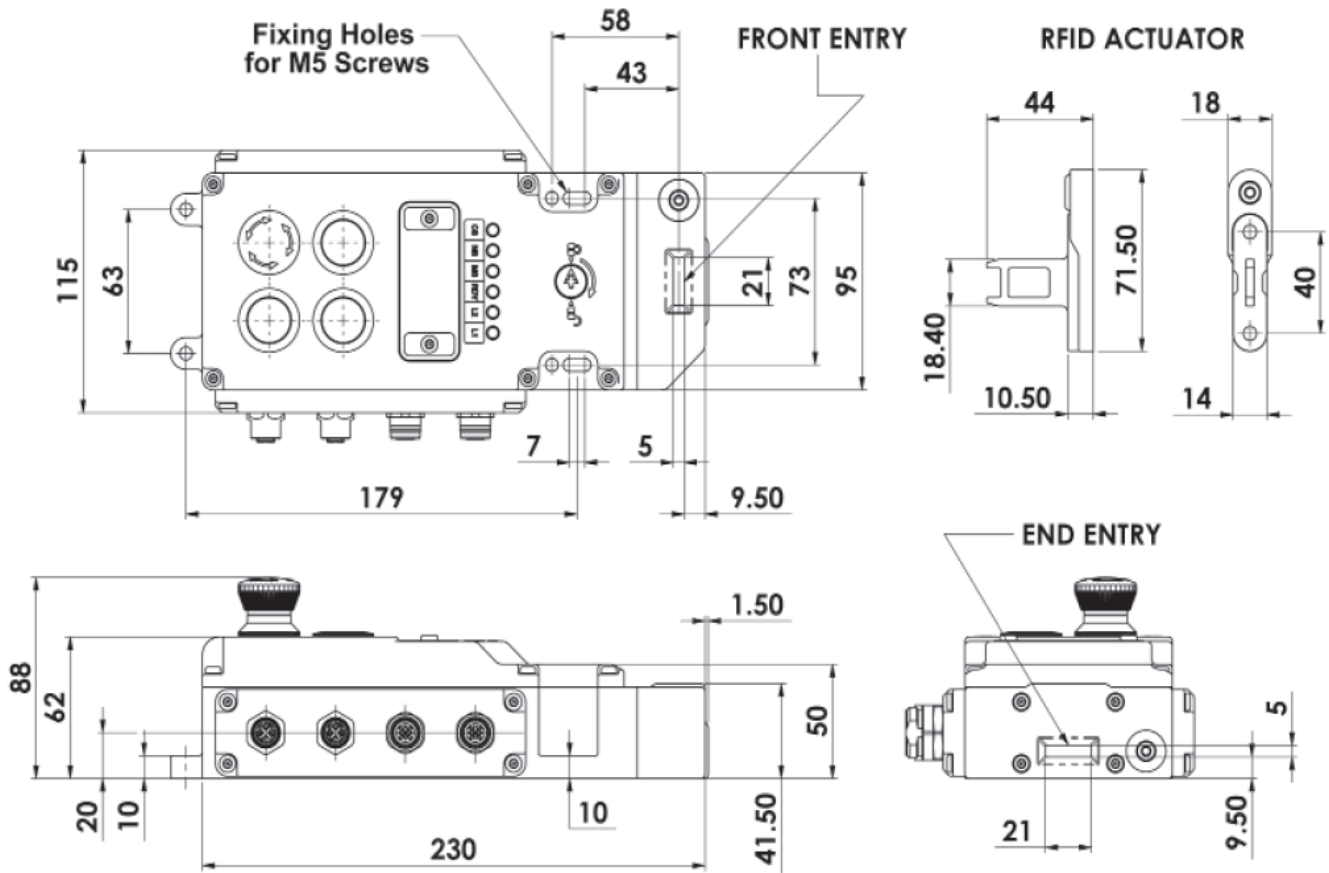

UGB-NET with Rear Release

