



Tongue Interlock Switch with Guard Locking & RFID Coding

KLP-Z KLM-Z KL3-SS-Z Operating Instructions

Application:

The KLP-Z, KLM-Z, KL3-SS-Z Safety Interlock switches are designed to fit to the leading edge of machine guard doors to provide robust guard locking and provide a double tamper resistant interlock mechanism.

They are designed to provide robust position interlock detection for moving guards and will remain locked until the solenoid voltage is applied to the switch.

They can be used in conjunction with delay timers to provide the solenoid energise signal only after a pre-determined time has run down.

Operation:

The switch is rigidly mounted to the fixed frame of the guard or machine.

The actuator is fitted to the moving part (frame) of the guard and is aligned to the switch entry aperture.

The mechanical tongue actuator profile is designed to match a cam mechanism within the switch head and provides a not easily defeatable mechanical interlock. There is also an RFID coded actuator which aligns with a programmed receiver inside the switch housing during closing of the guard. Only when both actuators are correctly aligned and the RFID coding is verified correctly can the safety contacts close and allow the machine start circuit to be enabled.

When the solenoid is energised the safety contacts are opened and the machine control circuit is broken.

IMPORTANT: The switches must be connected to a safety controller (or safety relay) to monitor the OSSD outputs.

When connected in series to a PLe Category 4 controller they will maintain PLe safety levels to ISO13849-1.

IMPORTANT:

Record any RFID codes as required by factory rules or with reference to any risk assessment for the particular application.

The risk assessment for the particular application should include the risk of spare actuators. Spare actuators should not be readily available and must be securely controlled.

The safety functions and mechanics must be tested regularly. For application where infrequent guard access is foreseeable, the system must have a manual function test to detect a possible accumulation of faults. At least once per month for PLe Cat 3/4 or once per year for PLD Cat 3 (ISO13849-1). Where possible it is recommended that the control system of the machine demands and monitors these tests, and stop or prevents the machine from starting if the test is not done, (see ISO14119).

It is the responsibility of the user to ensure the correct overall functionality of its systems and machines.

Ensure that the switch holding force (Fzh) is sufficient to withstand the static forces applied during normal use and dynamic effects caused by bouncing of the guard shall not create an impact reaction force which exceeds the holding force. If the expected impact reaction forces are higher than the specified holding force for the switch, then design measures must be applied to avoid the force.

IDEM, its subsidiaries and affiliates, are not in a position to guarantee all of the characteristics of a given system or product not designed by IDEM.

Installation:

- Installation of all IDEM interlock switches must be in accordance with a risk assessment for the individual application. Installation must only be carried out by competent personnel and in accordance with these instructions.
- M5 (or appropriate) mounting bolts must be used to fix the switch and actuator mounting plates. The tightening torque to ensure reliable fixing is 4.0 Nm. Tightening torque for the lid screws and cable glands must be 1.5 Nm to ensure the IP seal. Do not mount adjacent switches or actuators closer than 100mm.
- Always fit a mechanical stop to the guard to prevent damage to the front of the switch. Always ensure correct alignment of actuator with front apertures of the switch and guide. Use alignment guides to ensure that the actuator enters the switch without interfering with the sides of the aperture. If fitted, ensure access to at least one of the auxiliary release points. The switch can be positioned / shielded to prevent unintended actuation of the auxiliary release. The release function is achieved by use of a tool and is to be used in exceptional circumstances. If used the release can be protected by use of a tamper coating to protect against unintended operation. If operated this tamper protection must be restored. Always fit the aperture plug to the unused entry aperture to prevent debris entering the switch mechanism.
- The RFID code is factory set. For instances where replacement of the RFID actuator is required please contact IDEM via e-mail: technical@idemsafety.com.
- After installation check operation of all control circuits and the locking function. For applications with a run down time after removing power, ensure that the correct timing allowance has been made before the solenoid is energised.

Maintenance:

Every month: Check correct operation of all circuits and the Lock function. If the actuator shows signs of bending or the switch head housing displays mechanical damage then remove and replace.

IDEM will not accept responsibility for failure of the switch functions if the installation and maintenance requirements shown in this sheet are not implemented.

Every 6 months: Isolate power and remove cover. Check screw terminal tightness and check for signs of moisture ingress. Never attempt to repair any switch.

THESE INSTRUCTIONS FORM PART OF THE PRODUCT WARRANTY.

Dimensions (mm):

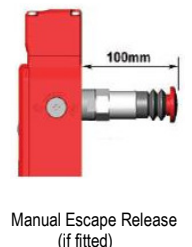
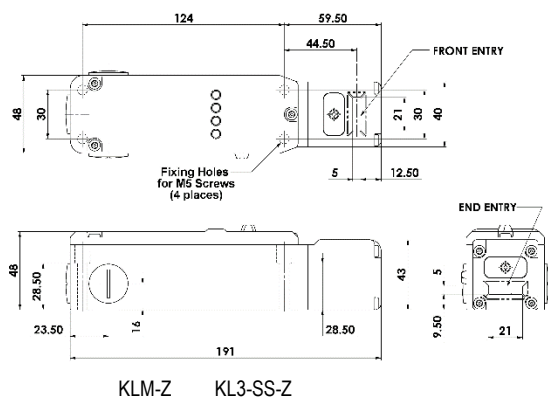
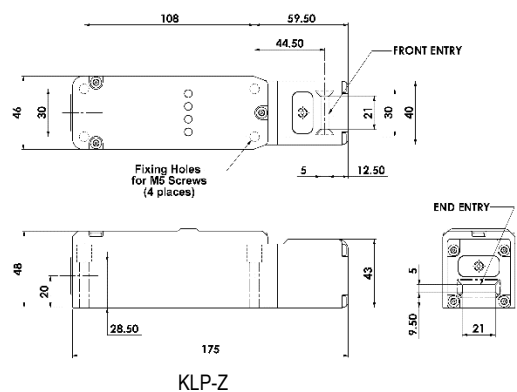
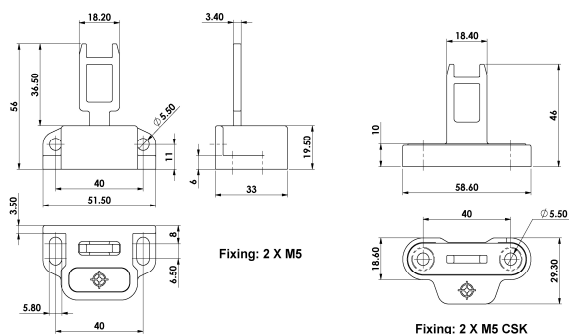
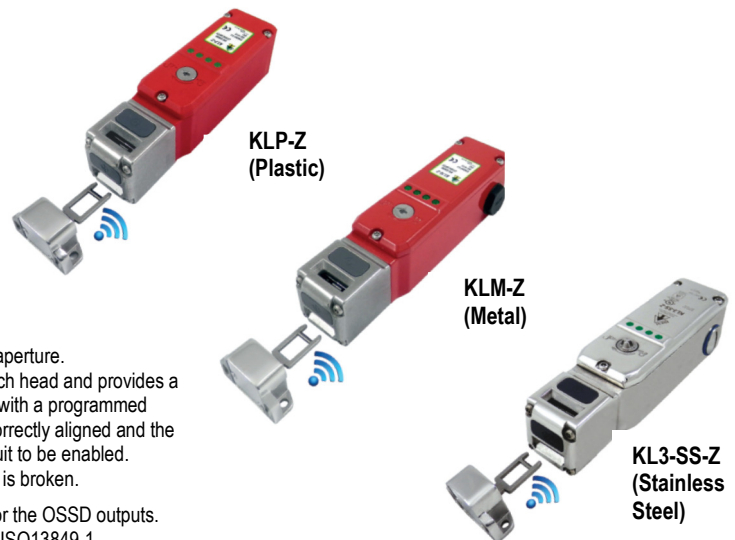

Tongue Interlock Switch with Guard Locking & RFID Coding



WARNING:

DO NOT DEFEAT, TAMPER, OR BYPASS THE SAFETY FUNCTION. FAILURE TO DO SO CAN RESULT IN DEATH OR SERIOUS INJURY.

AVERTISSEMENT:

NE PAS DESACTIVER, MODIFIER, RETIRER, OU CONTOURNER CETI INTERVERROUILLAGE IL PEUT EN RESULTER DES BLESSURES GRAVES DU PERSONNEL UTILISATEUR

Original Instructions

To request this datasheet in other languages please contact info@idemsafety.com
 Um dieses Datenblatt in Deutscher Sprache wenden Sie sich bitte anfordern info@idemsafety.com
 Pour obtenir cette fiche en Français, veuillez contacter info@idemsafety.com
 Para solicitar esta hoja de datos en Español, por contacto con info@idemsafety.com

GUARD	
Guard Closed and Locked	Green (Steady)
Guard Closed and Unlocked	Green (Flash)
Code Incorrect	Red (Flash)
Guard Open	Red

INPUT	
Safety Inputs On	Green (Steady)
Safety Input Missing	Green (Flash)
Safety Inputs Off	Off
Internal fault	Red (Steady)

OUTPUT	
Safety Outputs On	Green (Steady)
Safety Outputs Off	Off
External fault	Red (Flashing)

SOLENOID	
Solenoid Energised	Red
Solenoid De-energised	Off

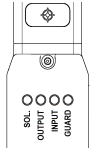

Quick Connect Pin view from switch (M12)	Terminal	Switch Circuit
2	R+	Supply +24V.dc
3	0V	Supply 0V.dc
7	11	Safety Input 1
1	12	Safety Output 1
4	21	Safety Input 2
6	22	Safety Output 2
8	44	Guard open signal +24V.dc out
N/A	34	Guard unlocked signal +24V.dc out
5	S+	Unlock signal Apply +24V.dc

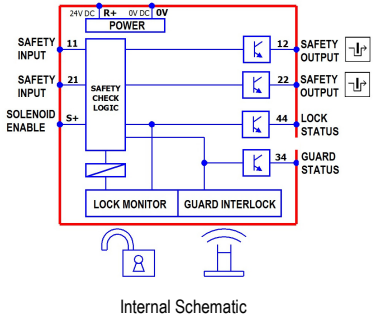

Technical Data:

Standards:	IEC60947-5-1 IEC60947-5-3 ISO14119 ISO13849-1 IEC62061 UL60947-5-1	
Supply Voltage	24Vdc (+/- 10%) SELV/PELV or Class 2	
Power Consumption	R+ (50mA Max.)	
	S+ (500mA Max.) (Solenoid)	
Safety Circuits	24Vdc 200mA max. switching.	
Auxiliary Circuits (34 & 44)	24Vdc 200mA max. Output feed.	
Rated Insulation Voltage	500VAC	
Rated Impulse withstand	1000VAC	
Holding Force (ISO14119)	KLP-Z: F1Max 2000N Fzh 1538N	KLM-Z KL3-SS-Z: F1Max 3000N Fzh 2307N
Coding level (ISO14119)	Type 4 High	
Actuator insertion for locking	5mm	
Sao / Sar (RFID)	15mm / 25mm	
Operating Frequency	1Hz	
Actuator entry minimum radius	175mm	
Body Material	KLP-Z: Polyester	
	KLM-Z: Die cast - Painted red	
	KL3-SS-Z: Stainless Steel 316	
Head Material	Stainless Steel 316	
Mechanical Actuator Material	Stainless Steel 316	
Enclosure Protection	IP67 (IP69K KL3-SS-Z version only).	
Operating Temperature	-25°C to +40°C	
Mechanical Life Expectancy (B10d)	2.5 x 10 ⁶ cycles at 100mA load	
Vibration	IEC68-2-6, 10-55Hz+1Hz	
	Excursion: 0.35mm, 1 octave/min	

Schematic example.
 Connected to SCR-31P-i relay to give Ple to ISO13849-1.
 Stop Button, Lock Release Button, Start Button, External Lamps.

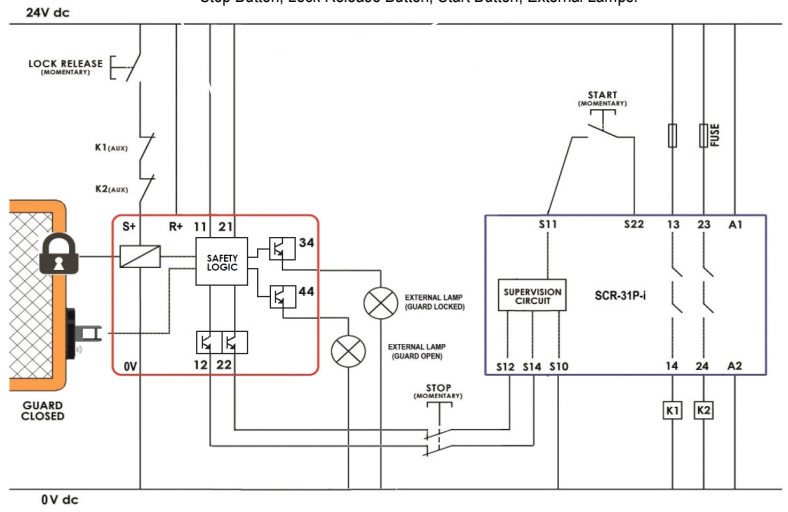

Safety Classification for Guard position monitoring:

Characteristic data according to IEC62061 (used as a subsystem)

Safety Integrity Level	SIL 3	
PFH (1/h)	1.0 E-09	Corresponds to 1% of SIL3
PFD (Av.)	8.7 E-05	Corresponds to 9% of SIL3
Proof Test Interval T ₁	20a	

Characteristic data according to EN ISO13849-1

Performance Level	e	
Category	Cat 4.	
MTTF _d	771a	
Diagnostic Coverage DC	High	

Information with regard to UL Standards: Type 1 enclosure. Use Class 2 power supply or equivalent. Maximum temperature 40°C. Use 16-28AWG copper conductors (rated 90°C). Terminal Torque 6 lb ins. (0.7Nm). Intended for same polarity use. Safety Circuits (11-12 & 21-22) 24V.dc 200mA max. Use one polymeric conduit connection. Not suitable for connection to rigid metal conduit. (Earth bonding terminal inside metal enclosures (if required). Use 16-12AWG conductors).

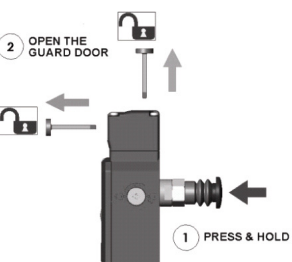

Where the Risk Assessment for the application permits, non latching escape release versions of the KLM-Z or KL3-SS-Z enable quick release of the switch lock in case of emergency. The switch can be mounted such that access to the release button is available from inside the active guard area. Pressing and holding the release button will release the lock mechanism and open the lock monitoring contacts, whilst the guard can be pushed open. Measures should be taken to reduce the risk of improper activation.

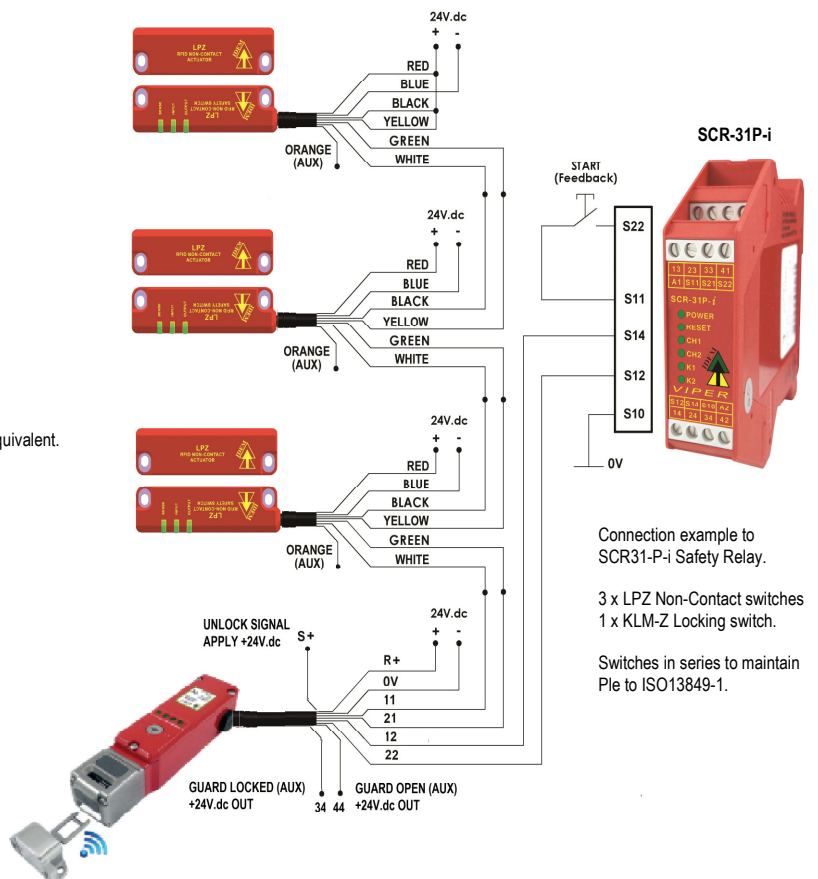

Connection example to SCR31-P-i Safety Relay.

3 x LPZ Non-Contact switches 1 x KLM-Z Locking switch.

Switches in series to maintain Ple to ISO13849-1.