

Power Quality Analyzer UMG 512-Pro

User manual and technical data

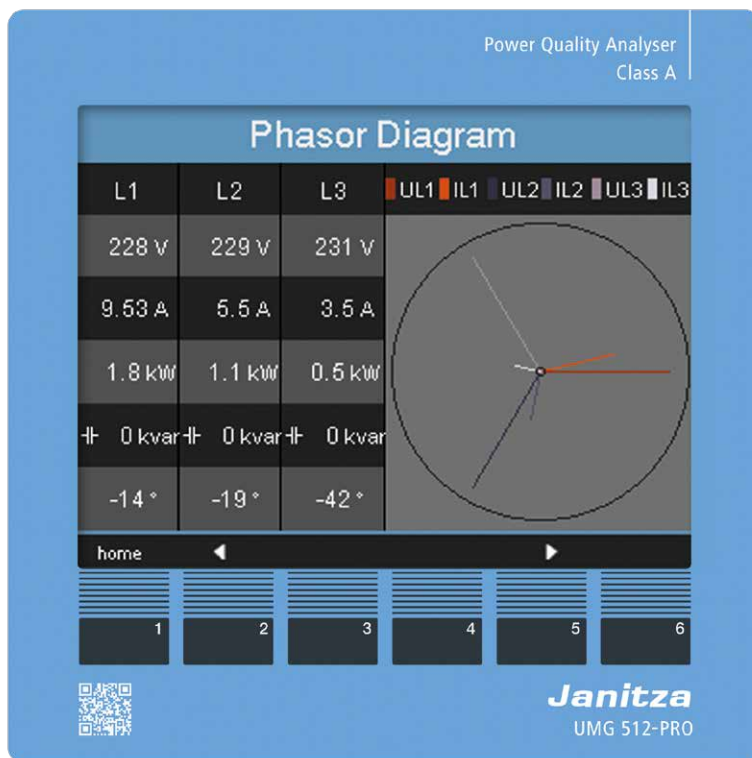

UMG 512-Pro Power Quality Analyzer

Doc. no.: 1.054.009.3.e
12/2025

The German version is the original edition of the documentation.

Subject to technical alterations.

The contents of our documentation have been compiled with great care and reflect the current state of the information available to us. Nonetheless, we wish to point out that updates of this document are not always possible at the same time as technical refinements are implemented in our products. Information and specifications are subject to change at any time.

Please see our website under www.janitza.com for the current version.

Table of contents

1. General	10
1.1 Disclaimer.....	10
1.2 Copyright notice.....	10
1.3 Technical changes.....	10
1.4 About this user manual.....	10
1.5 Meaning of symbols.....	10
1.6 Defective device/disposal.....	11
2. Safety	12
2.1 Display of warning notices and safety information.....	12
2.2 Hazard levels.....	12
2.3 Product safety.....	12
2.4 Dangers when handling the device.....	13
2.5 Electrically qualified personnel.....	14
2.6 Warranty in the event of damage.....	14
2.7 Safety information for handling current transformers and measurement devices with residual current measurement.....	14
2.8 Handling batteries/accumulators.....	15
3. Product description	16
3.1 Device description.....	16
3.2 Incoming goods inspection.....	16
3.3 Intended use.....	16
3.4 Performance characteristics.....	17
3.5 EU conformity declaration.....	18
3.6 FCC Declaration of Conformity.....	18
3.7 Scope of delivery.....	18
3.8 Accessories.....	18
3.9 Measuring method.....	19
3.10 Operating concept.....	19
3.11 GridVis® network analysis software.....	19

4. Structure of the device	20
4.1 Front panel and display.....	20
4.2 Rear view.....	21
5. Mounting	22
5.1 Installation location.....	22
5.2 Mounting orientation.....	22
5.3 Securing.....	22
6. Grid systems	24
6.1 Three-phase 3-conductor systems.....	25
6.2 Three-phase 4-conductor systems.....	25
6.3 Nominal voltages.....	26
7. Installation	28
7.1 Connection to a PC.....	28
7.2 Ground wire connection.....	29
7.3 Circuit breaker.....	29
7.4 Supply voltage.....	29
7.5 Measured voltage.....	30
7.5.1 Overvoltage.....	30
7.5.2 Frequency.....	30
7.6 Current measurement.....	31
7.6.1 Current direction.....	32
7.6.2 Summation current measurement.....	32
7.6.3 Ammeter.....	32
7.7 Connection variants.....	33
7.7.1 Main measurement.....	33
7.7.2 Auxiliary input.....	35
7.8 Residual current measurement.....	36
7.8.1 Failure monitoring.....	36
7.8.2 Example: Isolation of the residual current transformers.....	37
7.8.3 Temperature measurement.....	38
7.8.4 Example isolation of the temperature sensor.....	38

8. Interfaces	39
8.1 Shielding.....	39
8.2 RS-485 interface.....	40
8.2.1 Termination resistors.....	40
8.3 Profibus interface.....	41
8.3.1 Connecting the bus lines.....	41
8.4 Bus structure.....	42
8.5 Ethernet interface.....	43
9. Digital inputs and outputs	44
9.1 Digital inputs.....	44
9.1.1 S0 pulse input.....	45
9.2 Digital outputs.....	46
10. Operation	48
10.1 Button assignment.....	48
10.2 Measuring display “Home”.....	48
10.3 Measuring display.....	49
10.3.1 Main values.....	49
10.3.2 By-values.....	49
10.4 Select measuring display.....	50
10.5 Retrieving additional information.....	51
10.6 Deleting values.....	51
10.7 Transient list.....	52
10.8 Event list.....	53
11. Configuration	54
11.1 Languages.....	54
11.2 Communication.....	54
11.2.1 Ethernet (TCP/IP).....	55
11.2.2 Fieldbus.....	55
11.3 Measurement.....	56
11.3.1 Transformers.....	57
11.3.2 Transients.....	60
11.3.3 Events.....	62

11.3.4	Relevant voltage.....	63
11.3.5	Nominal frequency.....	63
11.3.6	Flicker.....	64
11.3.7	Temperature.....	64
11.4	System.....	65
11.4.1	Password.....	65
11.4.2	Reset.....	66
11.5	Display.....	67
11.6	Colors.....	68
11.7	Extensions.....	69
11.8	PTP configuration.....	70
11.8.1	Important Modbus parameters for the PTP configuration of the device.....	70
11.8.2	PTP parameter _MODE_NTP.....	70
11.8.3	Example: PTP timing according to IEEE 1588-2008 and clock types.....	71
12.	Commissioning.....	72
12.1	Supply voltage.....	72
12.2	Measured voltage.....	72
12.3	Frequency measurement.....	73
12.4	Direction of rotary field.....	73
12.5	Measured current.....	74
12.5.1	Phasor diagram examples.....	75
12.6	Residual current.....	75
12.7	Failure monitoring (RCM).....	76
12.7.1	Alarm status.....	76
12.8	Overrange.....	77
12.9	Control of the power measurement.....	77
12.10	Control of the communication.....	77
12.11	Communication in the bus system.....	78
12.11.1	RS-485.....	78
12.11.2	Profibus.....	79
12.12	Recording configuration.....	84
12.13	Digital inputs/outputs.....	86
12.13.1	Digital inputs.....	86
12.13.2	Pulse output.....	86

13. Device homepage	90
13.1 Measured values.....	91
13.1.1 Brief overview.....	91
13.1.2 Detailed measured values.....	92
13.1.3 Charts.....	93
13.1.4 RCM - Residual current measurement.....	93
13.1.5 Events.....	94
13.2 Power quality.....	95
13.3 Apps.....	98
13.3.1 Push Service.....	98
13.4 Information.....	99
13.4.1 Device information.....	99
13.4.2 Display.....	99
13.4.3 Downloads.....	99
14. Service and maintenance	100
14.1 Repairs and calibration.....	100
14.2 Front panel foil.....	100
14.3 Disposal.....	100
14.4 Service.....	100
14.5 Device adjustment.....	100
14.6 Calibration intervals.....	100
14.7 Firmware update.....	100
14.8 Battery.....	101

15. Technical data	102
15.1 Supply voltage.....	102
15.2 Voltage and current measurement.....	103
15.3 Residual current measurement.....	104
15.4 Temperature measurement input.....	105
15.5 Digital inputs and outputs.....	106
15.6 Interfaces.....	107
15.7 Performance characteristics of functions.....	108
15.7.1 Measurements at 50/60 Hz.....	108
15.7.2 Measurements in the range 15..45 / 65..440 Hz.....	109
15.8 Specifications according to IEC 61000-4-30.....	110
15.9 Dimensional drawings.....	111
16. Procedure in the event of a malfunction	112
17. Menu navigation overview	114
17.1 Configuration menu overview.....	114
17.2 Overview of measuring displays.....	115
18. Connection example	118

1. General

1.1 Disclaimer

Compliance with the informational products for the device is a prerequisite for safe operation and attaining the stated performance characteristics and product features.

Janitza electronics GmbH assumes no liability for bodily injury, material damage or financial losses which result from disregard of the informational products.

Ensure that your informational products are readily accessible in a legible form.

1.2 Copyright notice

© 2025 - Janitza electronics GmbH - Lahnau.
All rights reserved.

Any reproduction, processing, distribution or other use of this informational product, in whole or in part, is prohibited.

All trademarks and the rights arising from them are the property of the respective owners of these rights.

1.3 Technical changes

- Make sure that your device matches the user manual.
- This user manual applies to the UMG 512-Pro. Separate validities and distinctions are marked.
- First read and understand the documents associated with the product.
- Keep the documents associated with the product available for the entire service life and pass them on to any possible subsequent users.
- Find out about device revisions and the associated modifications of the documentation associated with your product at www.janitza.com.

1.4 About this user manual

If you have questions, suggestions or ideas for improvement of the user manual, please let us know via email at: info@janitza.com.

INFORMATION

This user manual describes the UMG 512-Pro and provides information on the operation of the device. Also consult the additional documentation relevant for this user manual, such as:

- Installation instructions.
- Data sheet.
- Safety information.
- As applicable, documents for expansion modules.
- Online help for the GridVis power grid monitoring software.

1.5 Meaning of symbols

The following pictograms are used in this manual:



Ground wire connection.



Inductive.

The current lags behind the voltage.



Capacitive.

The voltage lags behind the current.

1.6 Defective device/disposal

Before sending **defective devices, modules or components** back to the manufacturer for testing:

- Contact the manufacturer's Support department.
- Send devices, modules or components complete with all accessories.
- When doing so, please bear the terms for transportation in mind.

INFORMATION

Please return defective or damaged devices to Janitza electronics GmbH in accordance with the shipping instructions for air or road freight (complete with accessories).
Observe special regulations for devices with built-in batteries or rechargeable batteries!

Do not attempt to open or repair the device (the component) on your own because otherwise all warranty claims become invalid!

For the **Disposal** of the device please observe national regulations! Dispose of individual parts, as applicable, depending on their composition and existing country-specific regulations, e.g. as

- Electronic waste,
- Batteries and rechargeable batteries.
- Plastics.
- Metals.

Engage a certified disposal company to handle scrapping as needed.

Information on service and maintenance of your device can be found in chapter „14. Service and maintenance“ on page 100.

2. Safety

The chapter on Safety contains information which must be observed to ensure your personal safety and avoid material damage.

2.1 Display of warning notices and safety information

The warning notices shown below

- are found throughout all of the documentation,
- can be found on the devices themselves,
- indicate potential risks and hazards,
- underscore aspects of the information provided that clarifies or simplifies procedures.



The additional symbol on the device itself indicates an electrical danger that can result in serious injuries or death.



This general warning symbol draws attention to a possible risk of injury. Be certain to observe all of the information listed under this symbol in order to avoid possible injury or even death.



2.2 Hazard levels

Warning and safety information is marked by a warning symbol, and the hazard levels are shown as follows, depending on the degree of hazard:

⚠ DANGER
Warns of an imminent danger which, if not avoided, results in serious or fatal injury.

⚠ WARNING
Warns of a potentially hazardous situation which, if not avoided, could result in serious injury or death.

⚠ CAUTION
Warns of an immediately hazardous situation which, if not avoided, can result in minor or moderate injury.

ATTENTION
Warns of an immediately hazardous situation which, if not avoided, can result in material or environmental damage.

i INFORMATION

Indicates procedures in which there is **no** hazard of personal injury or material damage.

2.3 Product safety

The device reflects current engineering practice and accepted safety standards, but hazards can arise nonetheless.

Observe the safety regulations and warning notices. If notices are disregarded, this can lead to personal injury and/or damage to the product.

Every type of tampering with or use of this device,

- which goes beyond the mechanical, electrical or other operating limits can lead to personal injury and/or damage to the product;
- constitutes “misuse” and/or “negligence” under the product’s warranty and thus voids the warranty for any possible resulting damage.

Read and understand the user manual before installing, operating, maintaining and using the device.

Only operate the device when it is in perfect condition and in compliance with this user manual and the associated, included documents. Send defective devices back to the manufacturer in compliance with proper transport conditions. Retain the user manual throughout the service life of the device and keep it at hand for consultation.

When using the device, also observe the legal and safety regulations for your system that are applicable for the respective use case.

2.4 Dangers when handling the device

When operating electric devices, it is unavoidable for certain parts of these devices to conduct hazardous voltage. Consequently, severe bodily injury or material damage can occur if they are not handled properly.

Therefore, when handling our devices, always observe the following:

- do not exceed the limit values specified in the user manual and on the rating plate! This must also be observed during testing and commissioning!
- Safety and warning notices in all documents that belong to the devices!

WARNING

Disregarding the connection conditions of the Janitza measurement devices or their components can lead to injuries and even death or to material damage!

- Do not use Janitza measurement devices or components for critical switching, control or protection applications where the safety of persons and property depends on this function.
- Do not carry out switching operations with the Janitza measurement devices or components without prior inspection by your plant manager with specialist knowledge! In particular, the safety of persons, material assets and the applicable standards must be taken into account!

WARNING

Risk of injury due to electrical voltage!

Severe bodily injury or death can result! Therefore please abide by the following:

- **Switch off your installation before commencing work! Secure it against being switched on! Check to be sure it is de-energized! Ground and short circuit! Cover or block off adjacent live parts!**
- **During operation and troubleshooting (especially for DIN rail devices), check your system for dangerous voltages and switch these off if necessary!**
- **Wear protective clothing and protective equipment in accordance with applicable guidelines when working on electrical systems!**
- **Before making connections to the device/the component, ground the device by means of the ground wire connection, if present.**
- **Do not touching bare or stripped leads that are energized! Equip stranded conductors with wire ferrules!**
- **Hazardous voltages can be present in all circuitry parts that are connected to the power supply.**
- **Protect wires, cables and devices with a suitable line circuit breaker/fuse!**
- **Never switch off, remove or tamper with safety devices!**
- **There can still be hazardous voltages present in the device or in the component even after it has been disconnected from the supply voltage (capacitor storage).**
- **Do not operate equipment with current transformer circuits when open.**
- **Only connect screw terminals with the same number of poles and design!**
- **Do not exceed the limit values specified in the user manual and on the rating plate! This must also be observed during testing and commissioning.**
- **Take note of the safety and warning notices in the documents that belong to the device!**

2.5 Electrically qualified personnel

To avoid bodily injury and material damage, only electrically qualified personnel are permitted to work on the devices and their components, modules, assemblies, systems and current circuits who have knowledge of:

- The national and international accident prevention regulations.
- Safety technology standards.
- Installation, commissioning, operation, disconnection, grounding and marking of electrical equipment.
- the requirements concerning personal protective equipment.

Electrically qualified persons within the scope of the technical safety information of all documents associated with the device and its components are persons who can furnish proof of qualification as an electrically skilled person.

 WARNING
<p>Warning against unauthorized manipulation or improper use of the device or its components! Opening, dismantling or unauthorized manipulation of the device and its components which goes beyond the mechanical, electrical or other operating limits indicated can lead to material damage or injury, up to and including death.</p> <ul style="list-style-type: none"> · Only electrically qualified personnel are permitted to work on the devices and their components, assemblies, systems and current circuits. · Always use your device or component only in the manner described in the associated documentation. · If there is discernible damage, send the device or the component back to the manufacturer!

2.6 Warranty in the event of damage

Any unauthorized tampering with or use of the device constitutes “misuse” and/or “negligence” under the product’s warranty and thus voids the warranty of any possible resulting damage. In this regard, please take note of section „3.3 Intended use“ on page 16.

2.7 Safety information for handling current transformers and measurement devices with residual current measurement

 WARNING
<p>Risk of injury due to large currents and high electrical voltage on the current transformers! Current transformers operated while open on the secondary side (high voltage peaks pose a hazard when touched) can result in severe bodily injury or death.</p> <ul style="list-style-type: none"> · Avoid operating the current transformers while open; short circuit the unloaded transformers! · Before interrupting the current supply, short circuit the secondary connections of the current transformers. Switch any test switches that automatically short circuit the secondary lines of the current transformers to the “Test” status (Check the test switch/short circuiting connection beforehand)! · Only use current transformers with basic insulation to IEC 61010-1:2010! · Caution, even current transformers rated as safe for open operation can pose a hazard when touched during operation while open! · Make sure that screw terminals for the current transformer connection on the device are adequately tightened! · Comply with the information and provisions in the documentation of your current transformers!

 CAUTION
<p>Risk of injury or damage to the meter due to high measurement currents at the connections of the current transformers! High measurement currents can cause temperatures of up to 80 °C (176 °F) on the connections of the current transformers</p> <ul style="list-style-type: none"> · Use wiring that is designed for an operating temperature of at least 80 °C (176 °F)! · The current transformers can be hot even after the power supply has been switched off. Allow the connections of the current transformers and the connecting cables to cool down before touching them!

 WARNING
<p>Risk of injury or damage to the meter due to improper use! Meters with residual current measurement can trigger warning pulses if limit values are exceeded, and these are used exclusively for monitoring residual currents or failure monitoring. Use of the warning pulses as a stand-alone protective device against electrical shock can lead to injury and even death!</p> <ul style="list-style-type: none"> · Do not use devices with residual current measurement as a stand-alone protective device. Employ suitable protective devices for your system!

 **CAUTION****Risk of injury or damage to the meter/your system due to short circuit!**

Inadequate insulation of the operating equipment at the residual current measurement input with respect to the supply circuits can cause voltages at the measurement input which represent a hazard when touched or damage to your device or system.

- **Ensure reinforced or double insulation with respect to the supply circuits!**
- **Ensure galvanic isolation of the residual current measurement inputs from each other!**

2.8 Handling batteries/accumulators

The following apply for the battery used in the device:

 **CAUTION****Risk of injury due to fire or burns!**

The battery used in the device may cause fire or burns if used improperly.

- **Only replace the battery with the same type or types recommended by Janitza!**
- **Observe the polarity when installing the battery!**
- **Remove batteries only with non-conductive tools (e.g. plastic tweezers)!**
- **Do not recharge, disassemble, burn or heat batteries above 100 °C (212 °F)!**
- **Do not dispose of batteries with household waste! Follow the disposal instructions in the respective device documentation!**
- **Keep batteries away from children and animals!**
- **In case of damage, return devices with a soldered battery to the manufacturer, observing proper transport conditions!**

3. Product description

3.1 Device description

The device is:

- Designed for measuring power quality according to EN61000-4-30 in building installations, in distribution boards, circuit breakers and busbar trunking systems.
- Suitable for installation in stationary and weather-protected switchboards indoors.
- Suitable for use in 2-, 3- and 4-conductor networks and in TN and TT networks.
- Intended for current measurement via external $\dots/1$ A or $\dots/5$ A current transformers.
- Suitable for measurements in medium and high voltage networks only with the use of current and voltage transformers.
- For use in residential and industrial areas.
- Suitable for residual current measurement (RCM) via external residual current transformers with a nominal current of 30 mA.
- Not an independent protective device against electric shock.

The measurement results can be displayed and read out and further processed via the interfaces of the device.

This operating manual only describes the operation of the device via the 6 buttons. The GridVis® network analysis software has its own "online help".

 CAUTION
Malfunction and damage of the device or risk of injury due to improper connection. Improperly connected devices can deliver incorrect measured values, damage the device or pose a risk of injury to persons. Observe the following:
<ul style="list-style-type: none"> · That measured voltages and currents come from the same network. · Do not use the device for measuring direct current! · Ground current-conducting switchboards!

 CAUTION
The residual current measurement monitors the residual currents via external current transformers and, if a threshold value is exceeded, can trigger a warning signal. The device is therefore not an independent protective device against electric shock.

3.2 Incoming goods inspection

The prerequisites for trouble-free and safe operation of this device include proper transport, storage, setup and assembly, as well as proper operation and maintenance.

Exercise due caution when unpacking and packing the device, do not use force and only use suitable tools.

Check the devices for flawless mechanical condition by visual inspection.

Please check the scope of delivery for completeness before you start installing the device.

If it can be assumed that safe operation is no longer possible, the device must be taken out of operation immediately and secured against unintentional start-up. It can be assumed that safe operation is no longer possible if the device, for example:

- has visible damages,
- no longer functions despite an intact power supply,
- was subjected to extended periods of unfavorable conditions (e.g. storage outside of the permissible climate thresholds without adjustment to the room climate, condensation, etc.) or transport stress (e.g. falling from an elevated position, even without visible external damage, etc.).

3.3 Intended use

The device is:

- Only for use in the industrial sector.
- Intended for installation in switchboard cabinets and small distribution boards.
- Not intended for installation in vehicles! Use of the device in non-stationary equipment constitutes an exceptional environmental condition and is only permissible by special agreement.
- Not intended for installation in environments with harmful oils, acids, gases, vapors, dusts, radiation, etc.
- Designed as an interior meter.

Safe and trouble-free operation of the device requires proper transport, storage, assembly, installation, operation and maintenance.

3.4 Performance characteristics

General

- Front panel installation device with dimensions of 144 x 144 mm
- Connection via screw terminals
- Color graphic display, 320 x 240, 256 colors
- Operation via 6 buttons
- 4 voltage and 4 current measurement inputs
- 2 residual current inputs with failure monitoring
- 1 temperature measurement input
- 2 digital outputs and 2 digital inputs
- 16-bit A/D converter, data memory with 256 MByte flash, SDRAM of 32 Mbytes
- RS-485 interface (Modbus RTU, slave, up to 921 kbps)
- Profibus DP/V0
- Ethernet (web server, email)
- Acquisition of more than 2000 measured values
- Clock and battery
- Working temperature range of -10 °C ... +55 °C

Measurement

- Measurement in TN and TT networks
- Continuous sampling of the voltage and current measurement inputs at 25.6 kHz
- Frequency range of the fundamental oscillation, 15 Hz .. 440 Hz
- Acquisition of transients > 39 µs and storage with up to approx. 330,000 sampling points
- Measuring range, current 0.0017 Arms
- True effective value measurement (TRMS)
- Continuous sampling of the voltage and current measurement inputs
- Continuous monitoring of residual currents with failure monitoring
- Temperature measurement
- Measurement of power quality according to DIN EN61000-4-30, class A
- Flicker measurement according to DIN EN61000-4-15:2011, class F1
- Working measurement, measurement uncertainty according to DIN EN50470-3:
 - Class C for ..5 A transformers
 - Class B for ..1 A transformers
- Measurement of harmonics of 1st to 63rd order according to DIN EN61000-4-7 class 1, for:
 - UII, UII, I, P (consumption/del.)
 - Q (ind./cap.)
- Measurement of interharmonics of 1st to 63rd order according to DIN EN 61000-4-7 class 1, for (UII, UII, I)
- Analysis and evaluation according to DIN EN 50160 with the GridVis® programming software included in the scope of delivery
- Programming of custom applications in Jasic

INFORMATION

All supplied options and design variants are described on the delivery note.

3.5 EU conformity declaration

Please see the EU declaration of conformity posted at www.janitza.com for the laws, standards and directives applied by Janitza electronics GmbH for the devices. The CE conformity marking requirements for the device arise from the EU conformity declaration and the laws, standards and directives mentioned therein.

3.6 FCC Declaration of Conformity

The device:

- complies with Part 15 of the FCC Rules for Class B digital devices (limits to protect against harmful interference in a residential installation).
- generates, uses and can radiate high-frequency energy
- can cause harmful interference to radio communications if not installed and used properly. There is no guarantee that interference will not occur in a particular installation.

If there is radio or television reception interference, which can be determined by turning the device on and off, proceed as follows:

- Align or reposition the receiving antenna.
- Increase the distance between the device and the radio/television receiver.
- Connect the device and the radio/television receiver in different circuits.
- if necessary, contact Janitza support or a radio/television technician.

Code of Federal Regulations, Title 47, Part 15, Subpart B - Unintentional Radiators.

3.7 Scope of delivery

Quantity	Part. no.	Designation
1	52 17 xxx ¹⁾	UMG 512-PRO
1	33 03 336	Installation instructions
1	33 03 347	“GridVis Software” Quick Guide
1	33 03 342	Safety instructions
1	52 17 250	Accessories pack UMG 512-PRO

¹⁾For part number see delivery note

3.8 Accessories

Part. no.	Designation
21 01 102	Battery type, Lithium CR2450, 3 V, (approval according to UL 1642)
13 10 539	Profibus connector, 9-pin DSUB
13 10 543	Profibus connector, 9-pin DSUB, angled
29 01 903	Seal, 144 x 144

3.9 Measuring method

The device:

- Measures continuously and calculates all RMS values using a 200 ms interval:
- Measures the true RMS value (TRMS) of the voltages and currents applied to the measurement inputs.

3.10 Operating concept

You can program the device and retrieve measured values in several ways:

- **Directly on the device** Via 6 buttons and the display.
- Via the **GridVis programming software**.
- Via the **device homepage**.
- The **Modbus protocol** can be used to change and retrieve data using the Modbus address list. This list is available via the device homepage.

3.11 GridVis® network analysis software

You can program the device and read out data using the GridVis network analysis software available at www.janitza.com. To do so, a PC must be connected to the device via a serial interface (RS-485 / Ethernet).

The GridVis network analysis software allows you to:

- Program the device.
- Configure and read out recordings.
- Analyze the data that has been read out according to EN 61000-2-4.
- Save data to a database.
- Display measured values graphically.
- Program customer-specific applications.

4. Structure of the device

4.1 Front panel and display

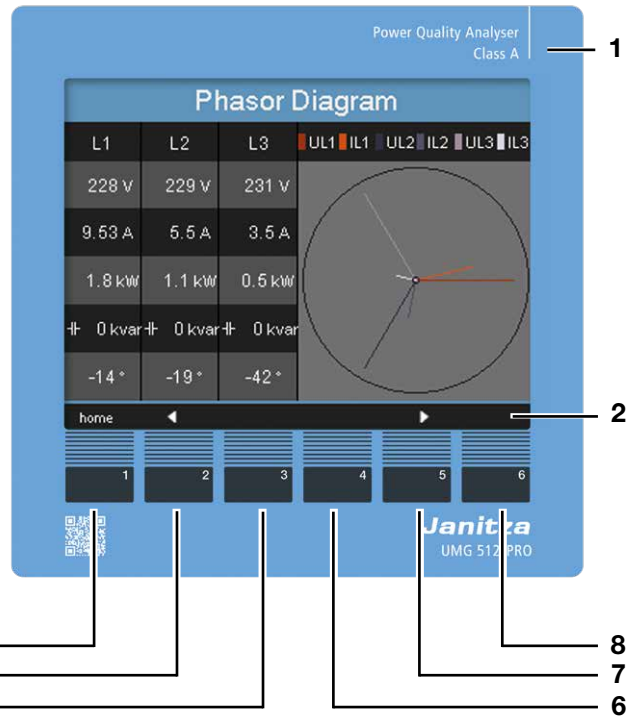

Fig. Front view UMG 512-PRO

- 1 Device type
- 2 Description of the function buttons
- 3 Button 1: Configuration menu, Back
- 4 Button 2: Select digit, switch between main values
- 5 Button 3: Decrement digit by 1, select by-values, select menu item
- 6 Button 4: Increment digit by 1, select by-values, select menu item
- 7 Button 5: Select digit, switch between main values
- 8 Button 6: Activate input, confirm selection

4.2 Rear view

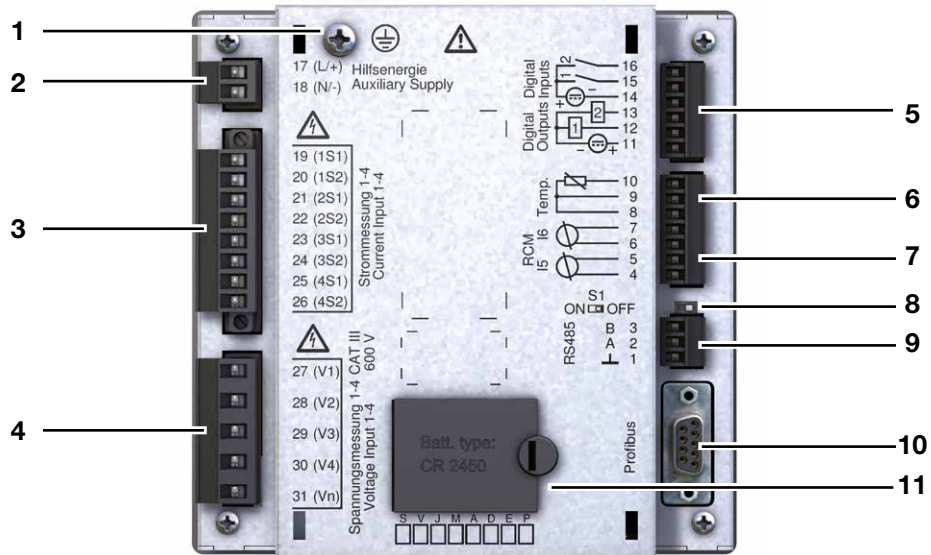

Fig. Rear view of UMG 512-PRO

- 1 Ground wire connection
- 2 Supply voltage
- 3 Current measurement inputs I1 to I4
- 4 Voltage measurement inputs V1 - V4 and Vn
- 5 Digital inputs/outputs
- 6 Temperature measurement input
- 7 Residual current measurement inputs I5 and I6
- 8 DIP switch S1
- 9 RS-485 interface
- 10 Profibus interface
- 11 Battery compartment

5. Mounting

5.1 Installation location

The device is suitable for installation in stationary and weatherproof switchboards indoors.

Provide grounding for conductive switchboards.

ATTENTION

Material damage due to disregard of the installation instructions!

Disregard of the installation instructions can damage or destroy your device.

Observe the information on the mounting orientation in the sections „5. Mounting“ and „15. Technical data“.

5.2 Mounting orientation

The cut-out dimension in the switchboard is 138^{+0.8} mm x 138^{+0.8} mm.

To achieve adequate ventilation, observe the following instructions:

- Install the device vertically.
- Maintain a minimum clearance of 50 mm towards the top and bottom.
- Maintain a minimum clearance of 20 mm towards the sides.

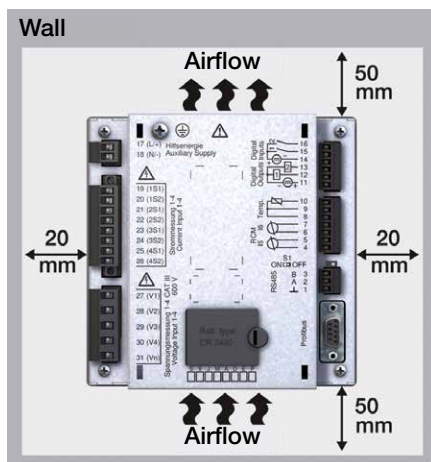

Fig. Rear view of the mounting orientation of the UMG 512-PRO

5.3 Securing

The device is fastened to the switchboard with two fastening clips, one at the bottom and one at the top. The fastening clips are first hooked onto the device.

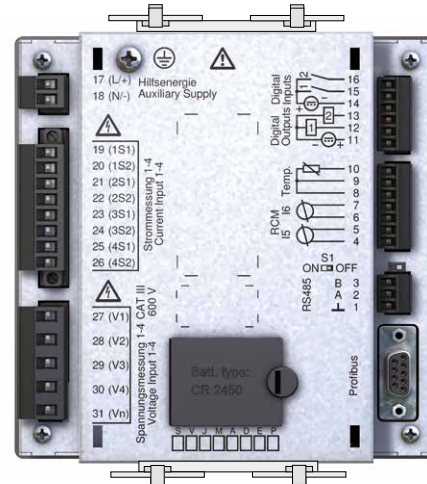

Fig. Arrangement of the fastening clips on the UMG 512-PRO

⚠ DANGER

Danger of electric shock!

Electric shocks lead to serious injuries, including death.

- Disconnect your system from the power supply before mounting and connecting the device!
- Secure it against being switched on!
- Check to be sure it is de-energized!
- Ground and short circuit!
- Cover or block off adjacent live parts!
- The installation must only be carried out by qualified personnel with electrical training!

6. Grid systems

Grid systems and maximum rated voltages according to DIN EN 61010-1/A1:

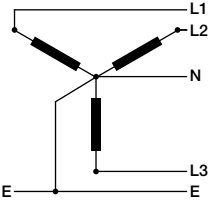
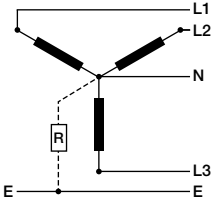
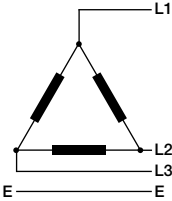
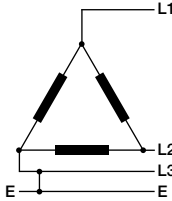
	Three-phase 4-conductor systems with grounded neutral conductor	Three-phase 4-conductor systems with ungrounded neutral conductor (IT networks)	Three-phase 3-conductor systems ungrounded	Three-phase 3-conductor systems with grounded phase
				
IEC	U_{L-N} / U_{L-L} : 417 VLN / 720 VLL	Only marginally suitable in ungrounded networks		U_{L-L} 600 VLL
UL	U_{L-N} / U_{L-L} : 347 VLN / 600 VLL			

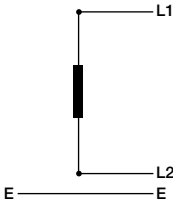
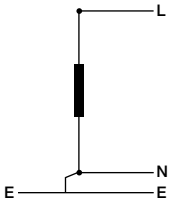
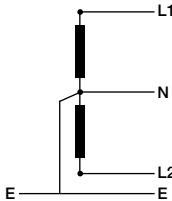
	Two-phase 2-conductor systems ungrounded	Single-phase 2-conductor systems with grounded neutral conductor	Split single-phase 3-conductor system with grounded neutral conductor
			
	Only marginally suitable in ungrounded networks	IEC U_{L-N} 480 VLN UL U_{L-N} 480 VLN	IEC U_{L-N} / U_{L-L} : 400 VLN / 690 VLL UL U_{L-N} / U_{L-L} : 347 VLN / 600 VLL

Application areas for the device

- 2-, 3- and 4-conductor networks (TN and TT networks).
- Residential and industrial areas.

WARNING

Risk of injury due to electrical voltage!

Rated surge voltages above the permitted over-voltage category can damage the insulation in the device. This impairs the safety of the device. This can result in serious injury or death.

- **Only use the device in environments which comply with the permissible rated surge voltage.**
- **Observe the limit values specified in the user manual and on the rating plate.**

6.1 Three-phase 3-conductor systems

The device is only suitable to a limited extent for use in IT networks, since the measured voltage is measured against the housing potential and the input impedance of the device causes a leakage current to ground. The leakage current can cause the insulation monitoring in IT networks to respond.

The connection variants with voltage transformers are suitable for IT networks with no restrictions.

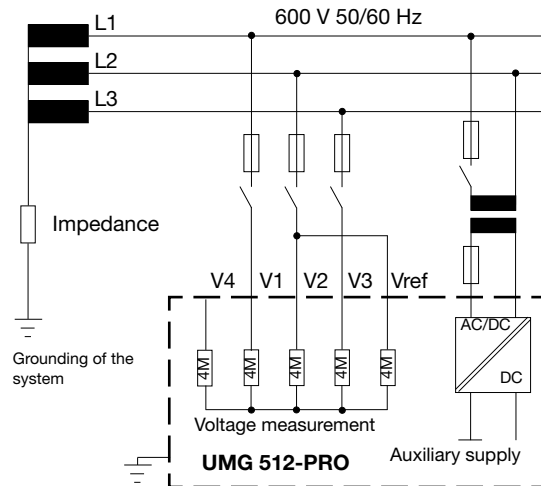

Fig. Schematic diagram, UMG in an IT network without N.

6.2 Three-phase 4-conductor systems

The device can be used in three-phase 4-conductor systems (TN, TT network) with a grounded neutral conductor. The components of the electrical system are grounded.

The voltage measurement in the device is designed for the overvoltage category 600 V CAT III (rated surge voltage 6 kV).

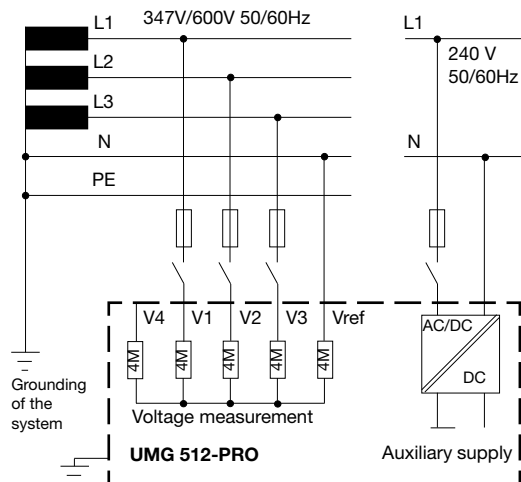

Fig. Schematic diagram, UMG in a TN network

6.3 Nominal voltages

The following figures show lists of the networks and associated nominal network voltages in which the device can be used.

U_{L-N} / U_{L-L}	
66 V / 115 V	
120V / 208V	
127V / 220V	
220V / 380V	
230V / 400V	
240V / 415V	
260V / 440V	
277V / 480V	
347V / 600V	
400V / 690V	
417V / 720V	

Maximum nominal voltage of the network according to UL

Maximum nominal voltage of the network

Fig. Nominal network voltages suitable for measurement inputs in a **three-phase 4-conductor network with a grounded neutral conductor** according to EN 60664-1:2003

U_{L-L}	
66 V	
115 V	
120 V	
127 V	
200 V	
220 V	
230 V	
240 V	
260 V	
277 V	
347 V	
380 V	
400 V	
415 V	
440 V	
480 V	
500 V	
577 V	
600 V	

Maximum nominal voltage of the network

Fig. Nominal network voltages suitable for measurement inputs in an **unearthed three-phase 3-conductor network** according to EN 60664-1:2003

7. Installation

7.1 Connection to a PC

When connecting the device to a PC, there are several possibilities:

1. Connection via an interface converter:

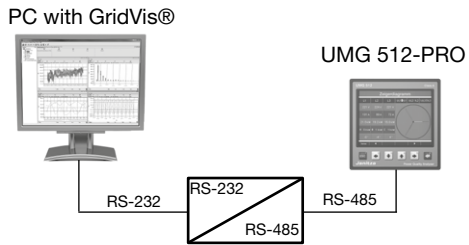

3. Connection via the network:

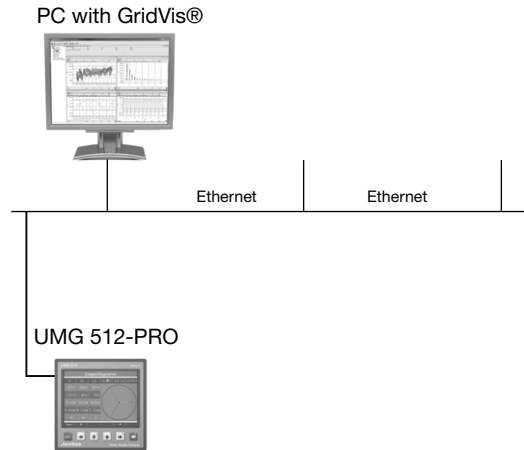

2. Direct connection via Ethernet:

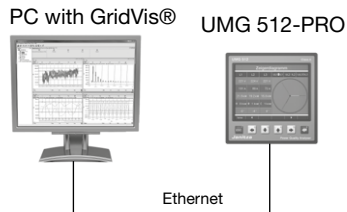

4. Using the UMG 512-PRO as a gateway for further UMGs

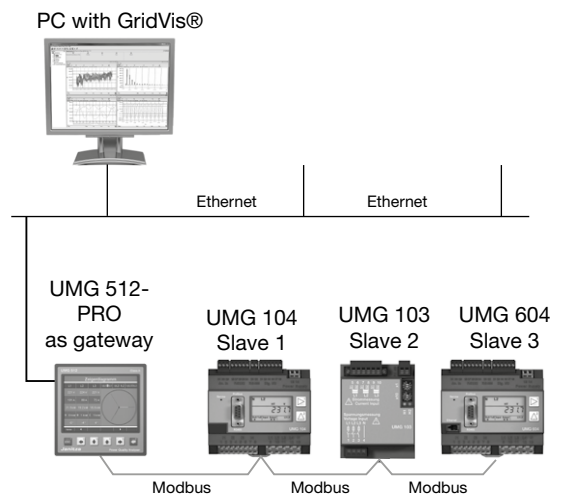

7.2 Ground wire connection

Use a ring cable lug to connect the protective conductor to the device.

7.3 Circuit breaker

When installing the device in a building, provide a suitable circuit breaker in order to disconnect the device from the power supply.

- Install the circuit breaker near the device and within easy reach of the user.
- Mark the switch as an isolation device.

7.4 Supply voltage

! WARNING

Risk of injury due to electrical voltage!

Severe bodily injury or death can result from:

- Touching bare or stripped leads that are energized.
- Device inputs that pose a hazard when touched.
- Disconnect your system from the power supply before mounting and connecting the device!
- Secure it against being switched on!
- Check to be sure it is de-energized!
- Ground and short circuit!
- Cover or block off adjacent live parts!

A supply voltage is required to operate the device. The level of the supply voltage for your device can be found on the rating plate.

Before applying the supply voltage, make sure that the voltage and frequency match the specifications on the rating plate.

The supply voltage must be connected via the plug-in terminals on the rear of the device.

Connect the supply voltage via a UL/IEC approved fuse.

i INFORMATION

The fuse is a line protection - it is not a device protection!

ATTENTION

Material damage due to disregard of the connection instructions!

Disregard of the connection instructions or exceeding the permissible voltage range can damage or destroy your device.

Before connecting the device to the supply voltage, please note:

- Voltage and frequency must correspond to the specifications on the rating plate!
- Observe the limit values as described (see section „15. Technical data“ on page 102)!
- In the building installation, secure the supply voltage with a UL/IEC listed line circuit breaker/fuse!
- Observe the following for the isolation device:
 - Install it close to the device and easily accessible for the user.
 - Mark it for the respective device.
- Do not tap the supply voltage from the voltage transformers.
- Provide a fuse for the neutral conductor if the neutral conductor terminal of the source is not grounded.

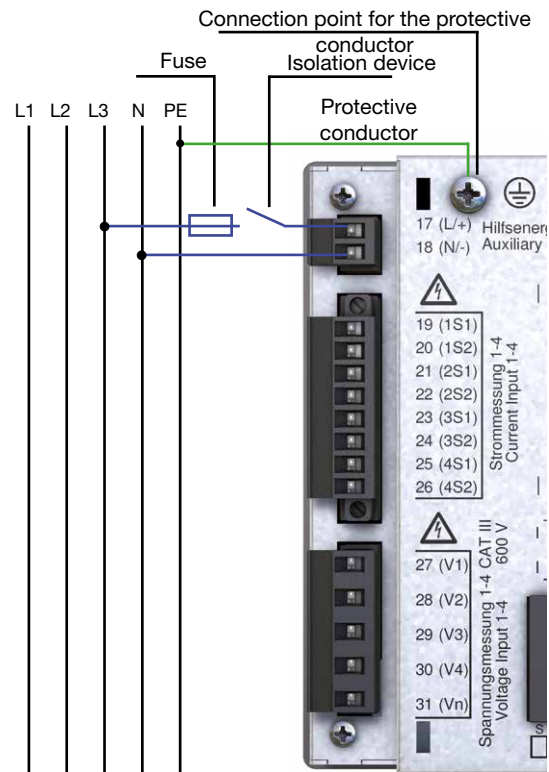

Fig. Connection example for the supply voltage

7.5 Measured voltage

The device has 4 voltage measurement inputs (V1 to V4) located on the back of the device.

- V1 to V3 are for the main measurement.
- V4 is for auxiliary measurement.

In the following, the connections are referred to as auxiliary and main measurement.

7.5.1 Overvoltage

The voltage measurement inputs are suitable for measurements in networks where overvoltages of category 600 V CAT III can occur.

7.5.2 Frequency

The device:

- Is suitable for measurement in networks in which the fundamental oscillation of the voltage is in the range from 15 Hz to 440 Hz.
- Measures the frequency only at the measurement inputs of the main measurement.

For the automatic determination (wide range) of the mains frequency, a voltage L1-N of more than 10 Vrms must be applied to voltage measurement input V1.

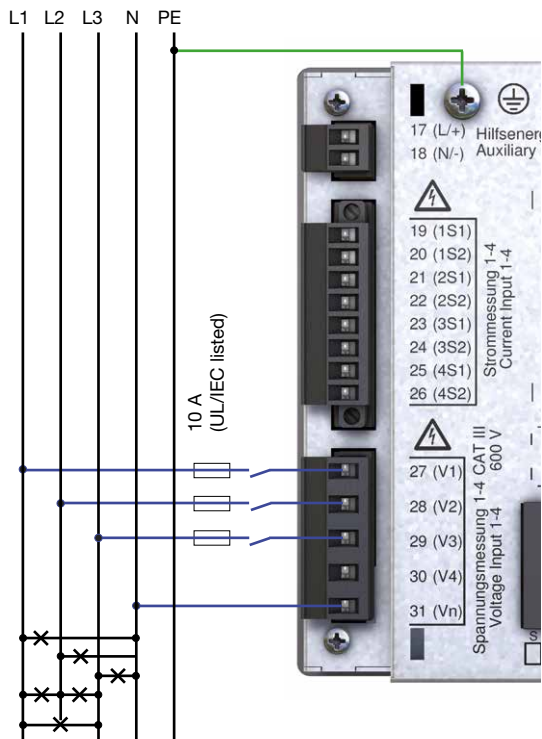

Fig. Connection example for voltage measurement.

⚠ WARNING

Risk of injury or damage to the device due to electrical voltage and improper connection!

Failure to comply with the connection conditions for the voltage measurement inputs can result in damage to the device or serious injury, including death.

Therefore, please observe the following:

- **Switch off your installation before commencing work! Secure it against being switched on! Check to be sure it is de-energized! Ground and short circuit! Cover or block off adjacent live parts!**
- **Do not apply a DC voltage**
 - to the voltage measurement inputs.
 - Equip the voltage measurement inputs with a suitable, marked fuse and isolation device (alternatively: line circuit breaker) located nearby.
 - The voltage measurement inputs are dangerous to touch.
- **Connect voltages that exceed the permissible nominal network voltages via a voltage transformer.**
- **Measured voltages and currents must originate from the same network.**

i INFORMATION

As an alternative to the fuse and isolation device, you can use a line circuit breaker.

i INFORMATION

In the case of a main measurement on a three-phase 3-conductor network, the auxiliary measurement can no longer be used as a measurement input.

i INFORMATION

To determine the frequency for a measurement with the auxiliary measurement, a voltage must be connected to the main measurement.

7.6 Current measurement

The device:

- Is designed for the connection of current transformers with secondary currents of $\dots/1$ A and $\dots/5$ A.
- Does not measure DC currents.
- Has current measurement inputs which can be loaded up to 120 A for 1 second.

The factory-set current transformer ratio is 5/5 A and must be adapted as needed for the current transformers used.

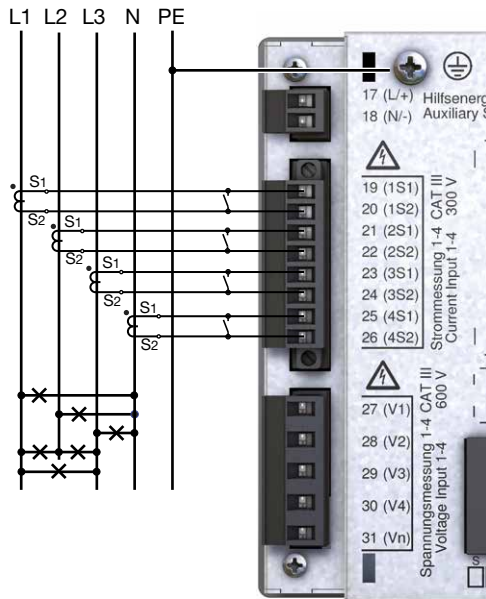

Fig. Connection example, "Current measurement via current transformer".

⚠ WARNING

Risk of injury or damage to the device due to electrical voltage and improper connection!
High measuring currents can cause temperatures of up to 80 °C (176 °F) at the connections.
Use wiring designed for an operating temperature of up to 80 °C (176 °F)!

⚠ WARNING

Risk of injury due to electrical voltage at current transformers!

Current transformers which are operated exposed on the secondary side can carry hazardous live high voltage peaks which can lead to serious bodily injury or death.

Therefore please abide by the following:

- **Switch off your installation before commencing work! Secure it against being switched on! Check to be sure it is de-energized! Ground and short circuit! Cover or block off adjacent live parts!**
- **Avoid exposed operation of the current transformers.**
- **Short-circuit unloaded current transformers.**
- **Before interrupting the current supply, short circuit the secondary connections of the current transformers.**
- **If there is a test switch which automatically short-circuits the secondary current transformer lines, it is sufficient to set it to the "Test" position, provided that the short-circuiters have been checked beforehand.**
- **Only use current transformers with basic insulation according to IEC 61010-1:2010.**
- **Fix the attached screw terminal to the device with the two screws.**
- **Even current transformers rated as safe for exposed operation are dangerous to touch if they are operated exposed.**

⚠ WARNING

Risk of injury due to high currents and high electrical voltages!

Severe bodily injury or death can result from:

- Touching bare or stripped leads that are energized.

· Dangerous live current measurement inputs of the device and at the current transformers.

Therefore, please note for your system:

- **Disconnect the supply of power before starting work!**
- **Secure it against being switched on!**
- **Check to be sure it is de-energized!**
- **Ground and short circuit! Use the ground connection points with the ground symbol for grounding!**
- **Cover or block off adjacent live parts!**

7.6.1 Current direction

You can correct the current direction for each phase individually on the device or via the serial interfaces provided. This means that in the case of incorrect connection, no subsequent reconnection of the current transformers is necessary.

7.6.2 Summation current measurement

For a summation current measurement via two current transformers, first set their total ratio on the device. The setting of the current transformer ratios is described in section „11.3.1 Transformers“.

Example:

The current is measured via two current transformers. Both current transformers have a ratio of 1000/5 A. The summation measurement is carried out with a summation current transformer of 5+5/5 A.

The device must then be adjusted as follows:

Primary current: 1000 A + 1000 A = 2000 A
 Secondary current: 5 A

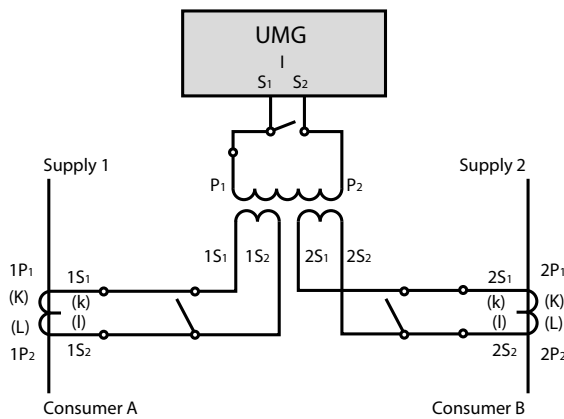

Fig. Example for current measurement via a summation current transformer.

⚠ WARNING

Disregard of the connection conditions of the transformers to Janitza measurement devices or their components can lead to injuries or even death or to material damage!

- Do not use Janitza measurement devices or components for critical switching, control or protection applications (protective relays)! It is not permitted to use measured values or measurement device outputs for critical applications!
- For Janitza measurement devices and their components use **only “Transformers for measurement purposes”** which are suitable for the energy monitoring of your system. Do **not use “Transformers for protection purposes”!**
- Observe the information, regulations and limit values in the usage information on **“Transformers for measuring purposes”**, specifically during testing and commissioning of the Janitza measurement device, the Janitza component and your system. Voltages above the permissible voltage range can destroy the device.

7.6.3 Ammeter

If you want to measure the current not only with the UMG, but also with an ammeter, connect the ammeter to the UMG in series.

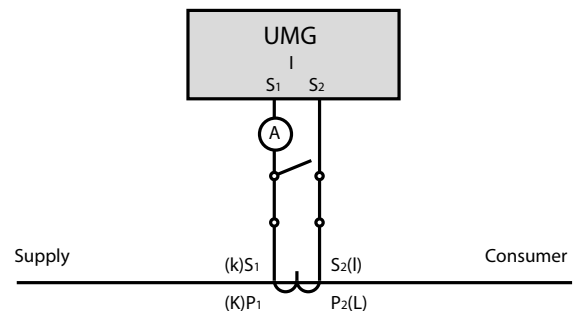
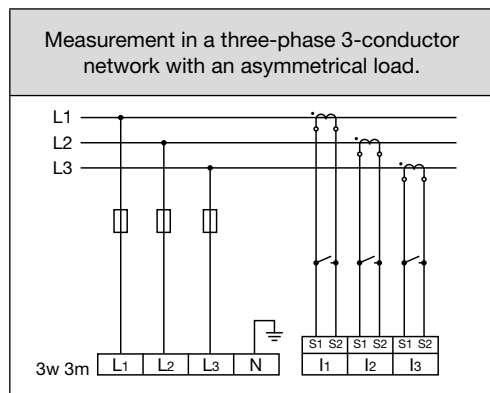
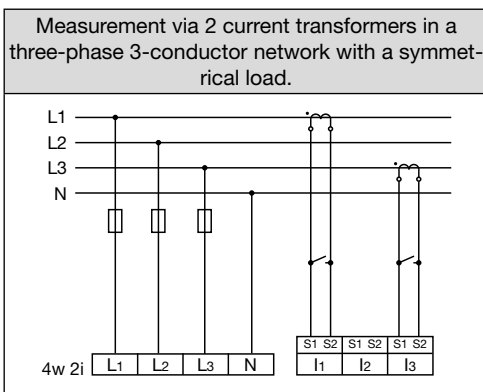
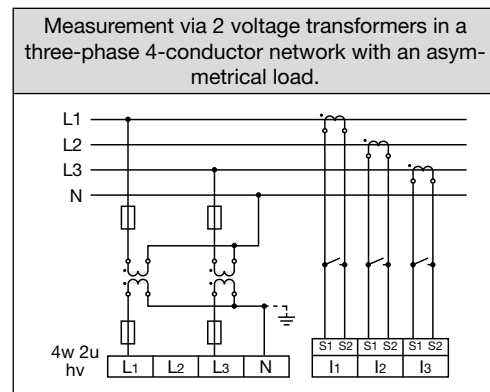
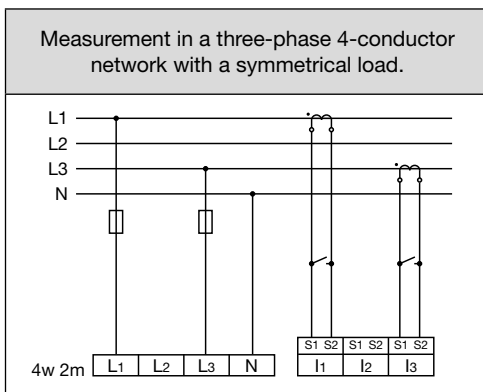
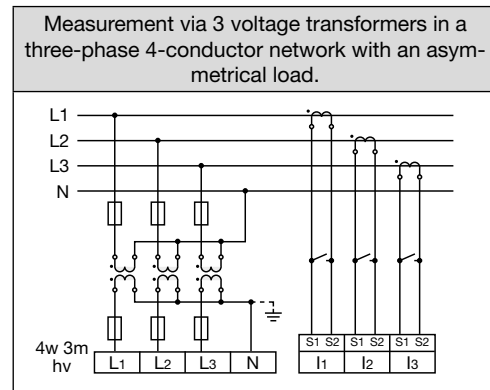
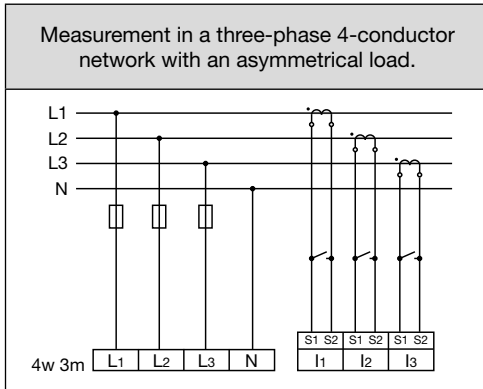

Fig. Circuit diagram with additional ammeter connected in series

7.7 Connection variants

7.7.1 Main measurement

Here are some circuit diagrams of the most common ways of connecting the measuring voltage to the device for the main measurement.



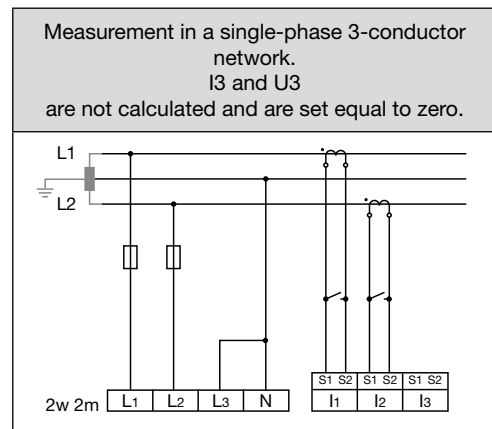
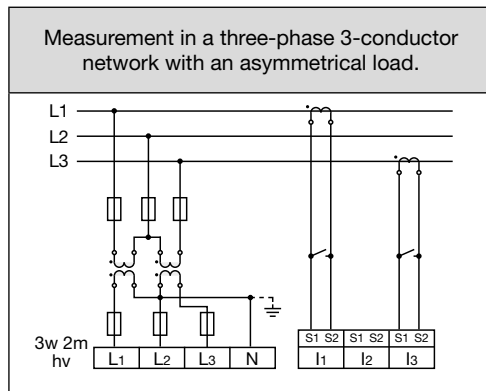
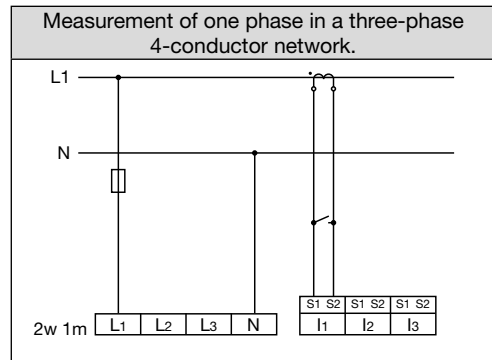
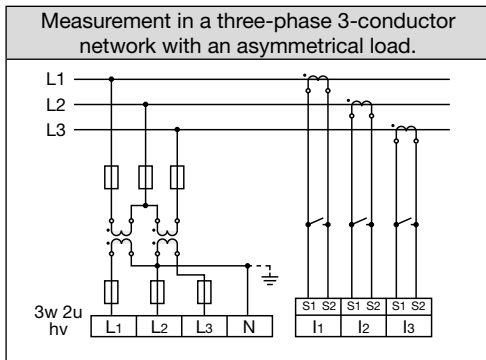
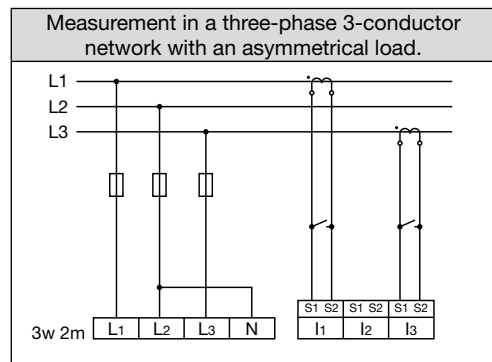
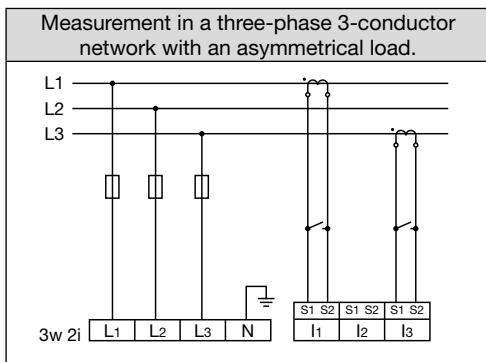
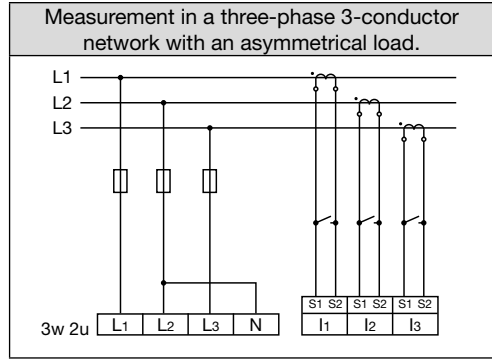
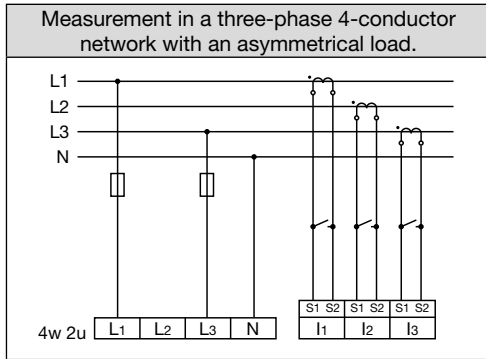

7.7.2 Auxiliary input

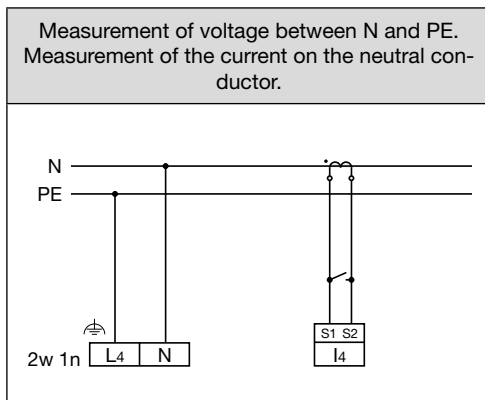
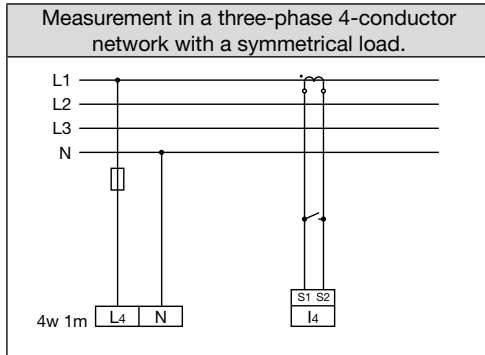

i INFORMATION

If the main measurement is connected to a three-phase 3-conductor network, the auxiliary measurement can no longer be used as a measurement input.

i INFORMATION

To determine the frequency for a measurement with the auxiliary measurement, a voltage must be connected to the main measurement.

i INFORMATION

Measured voltages and currents must originate from the same network.

7.8 Residual current measurement

The device:

- Is suitable for use as a residual current monitor (RCM) for monitoring AC currents and pulsating DC currents.
- Can measure residual currents according to IEC/ TR 60755 (2008-01)  of type A.
- Does not measure using direction selectivity. This means there is no direction-dependent differentiation of the residual currents of the grid and load side.

Connection of suitable external residual current transformers with a nominal current of 30 mA can be made on residual current transformer inputs I5 (terminals 4/5) and I6 (terminals 6/7).

7.8.1 Failure monitoring

The device monitors the ohmic resistance at the residual current measurement inputs.

If this is greater than 300 ohms, there is a failure of the residual current measurement. This can occur, for example, due to a cable break.

For more information on failure monitoring, see the section „12.7 Failure monitoring (RCM)“ on page 76.

⚠ CAUTION

Risk of injury or damage to the meter/your system due to short circuit!
 Inadequate insulation of the operating equipment at the residual current measurement input with respect to the supply circuits can cause voltages at the measurement input which represent a hazard when touched or damage to your device or system.

- **Ensure reinforced or double insulation with respect to the supply circuits.**
- **Isolate residual current measurement inputs galvanically from each other and galvanically from the supply voltage!**

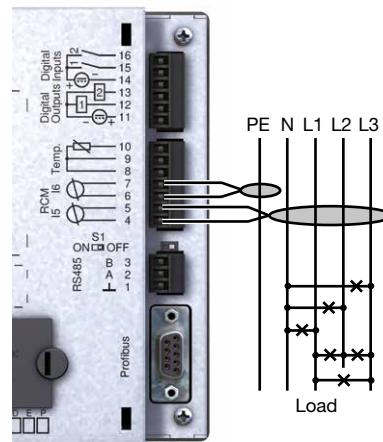

Fig. Connection variant, "Residual current measurement via current transformer"

i INFORMATION

- Ratios for the residual current transformer inputs can be configured via the GridVis power grid monitoring software.
- No connection diagram needs to be configured for measurement inputs I5 and I6!

7.8.2 Example: Isolation of the residual current transformers

A residual current transformer is used to measure on insulated mains wiring in a 300 V CAT III network.

Provide basic insulation for 300 V CAT III for the isolation of the network wiring and the isolation of the residual current transformer.

ATTENTION

Transmission error and material damage due to electrical malfunction.

With a cable length of more than 30 m, there is an increased probability of transmission errors and damage to the device due to atmospheric discharge!

Use a shielded cable for the connection to the residual current transformer inputs.

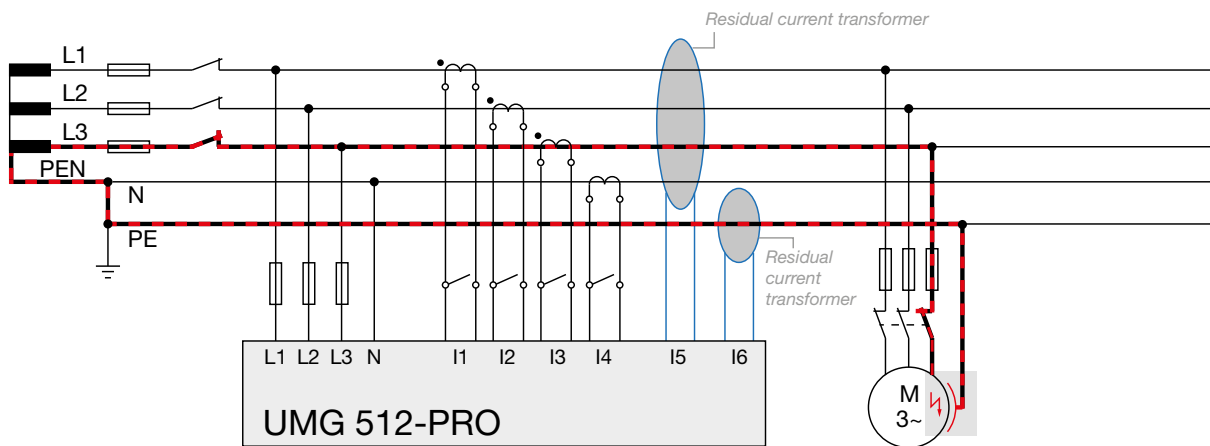

Fig. Example UMG with residual current monitoring via measurement inputs I5/I6.

⚠ WARNING

Risk of injury due to electrical voltage!

The Profibus, RS-485, temperature measurement input and residual current measurement input are not galvanically isolated from each other.

It is therefore essential to note that dangerous voltages at these inputs can have an effect on the respective other connections.

7.8.3 Temperature measurement

The device has a temperature measurement input designed for a maximum total load of 4 kOhms.

This refers to the sensor and the wire.

The temperature is measured via terminals 8 to 10.

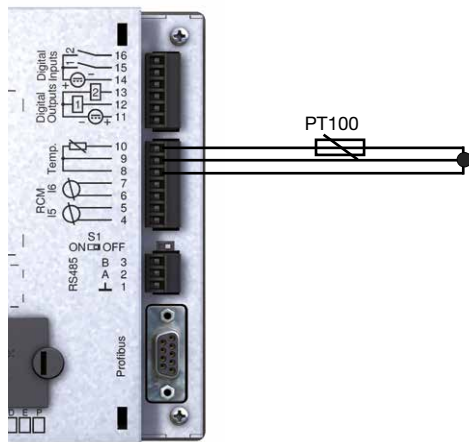

Fig. Connection example for temperature measurement via a PT100

7.8.4 Example isolation of the temperature sensor

A temperature sensor is to be used for measurement in the proximity of non-insulated mains wiring in a 300 V CAT III network.

The temperature sensor must have reinforced or double insulation for 300 V CAT III.

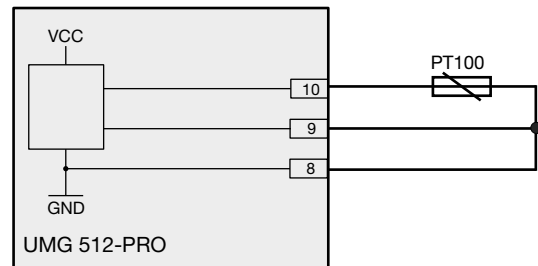

Fig. Schematic representation of the connection example

ATTENTION

Transmission error and material damage due to electrical malfunction.
 With a cable length of more than 30 m, there is an increased probability of transmission errors and damage to the device due to atmospheric discharge!
Use a shielded cable for connecting the temperature sensor.

WARNING

Risk of injury due to electrical voltage!
 The Profibus, RS-485, temperature measurement input and residual current measurement input are not galvanically isolated from each other.
It is therefore essential to note that dangerous voltages at these inputs can have an effect on the respective other connections.

CAUTION

Risk of injury or damage to the meter/your system due to short circuit!
 Inadequate insulation of the operating equipment at the analog inputs (temperature measurement and residual current measurement) with respect to the supply circuits can cause voltages at the measurement input which represent a hazard when touched or damage to your device or system.
Ensure reinforced or double insulation with respect to the supply circuits.

8. Interfaces

The device has the following interfaces with which it can be connected to other devices:

- RS-485
- Profibus
- Ethernet

8.1 Shielding

Provide a twisted and shielded cable for connections via the interfaces and observe the following points for shielding:

- Ground the shields of all cables leading into the cabinet at the cabinet entrance.
- Connect the shield to a noiseless ground and ensure a large surface area with good conductivity.
- Mechanically restrain the cables before the grounding clamp to prevent damage from cable movement.
- Use suitable cable glands, for example PG glands, to lead the cable into the switchboard cabinet.

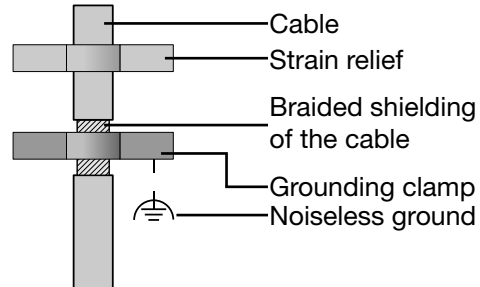

Fig. Shielding design at the entrance to the cabinet.

⚠ WARNING

Risk of injury due to high currents and high electrical voltages!

Atmospheric discharge can cause transmission errors and dangerous voltages on the device.

Therefore please abide by the following:

- **Connect the cable shielding to functional earth (PE) at least once.**
- **For larger sources of interference or frequency converters in the switchboard cabinet, connect the shielding to functional earth (PE) as close to the device as possible.**
- **Comply with the maximum cable length of 1,200 m at a baud rate of 38.4 kbps.**
- **Use shielded cables.**
- **Route interface cables spatially separated or additionally insulated from mains voltage-carrying system components.**

8.2 RS-485 interface

The RS-485 interface of this device is designed as a 3-pole plug contact and communicates using the Modbus RTU protocol.

The cables used must be suitable for an ambient temperature of at least 80°C.

Recommended cable type:

- Unitronic Li2YCY(TP) 2x2x0.22 (Lapp cable)

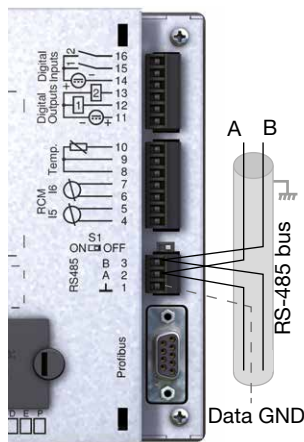
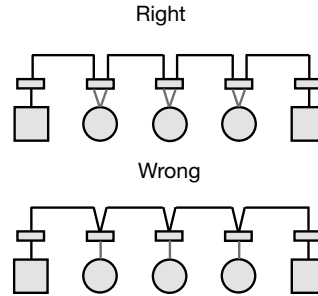

Fig. RS-485 connection example

8.2.1 Termination resistors

At the beginning and end of a segment, the cable must be terminated with resistors (120 Ω, 1/4 W).

Termination within the device is possible via DIP switch S1 of the device.



	Terminal strip in the switchboard cabinet.
	Device with RS-485 interface. (Without termination resistor)
	Device with RS-485 interface. (With termination resistor on the device)

⚠ WARNING

Risk of injury due to electrical voltage!
 The Profibus, RS-485, temperature measurement input and residual current measurement input are not galvanically isolated from each other.
It is therefore essential to note that dangerous voltages at these inputs can have an effect on the respective other connections.

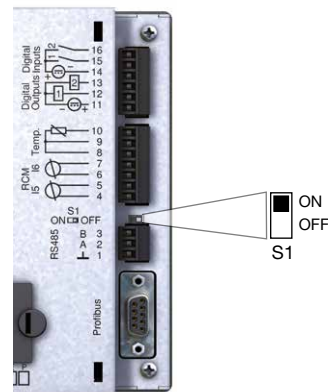

Fig. Termination activated via DIP switch (ON).

8.3 Profibus interface

This RS-485 interface, designed as a 9-pin DSub socket, supports the Profibus DP V0 Slave protocol.

For easy connection of incoming and outgoing bus lines, connect them to the device via a Profibus connector.

For connection, we recommend a 9-pin Profibus connector, e.g. from Phoenix of the type "SUBCON-Plus-ProfIB/AX/SC" with part number 2744380.

(Janitza Part. no.: 13.10.539)

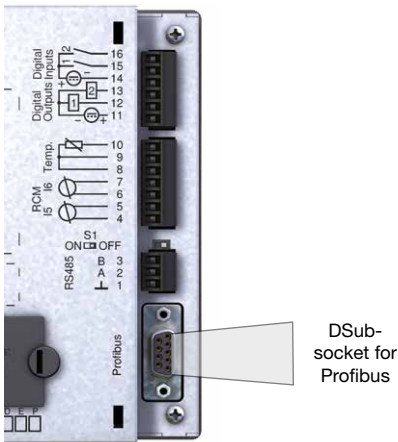

Fig. Rear view of UMG 512-PRO with DSub socket for Profibus

i INFORMATION

When using the device in a Profibus system, set the device address via the configuration menu as described in „11.2.2 Fieldbus“ on page 55!

8.3.1 Connecting the bus lines

1. Connect the incoming bus line to terminals 1A and 1B of the Profibus connector.
2. Connect the continuing bus line for the next device in the line to terminals 2A and 2B.
3. If no further device follows in the line, terminate the bus line with resistors by setting the switch on the Profibus connector to ON.

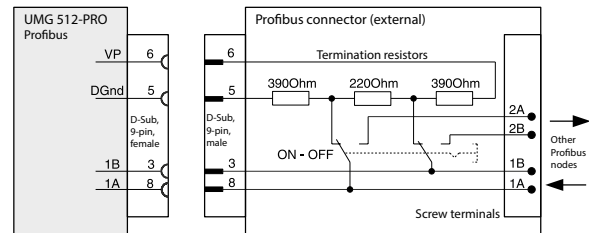

Fig. Profibus connector with termination resistors

Transmission speeds in kBit/s	max: Segment length
9.6; 19.2; 45.45; 93.75	1200 m
187.5	1000 m
500	400 m
1500	200 m
3000; 6000; 12000	100 m

Tab. Segment lengths according to Profibus specification.

⚠ WARNING

Risk of injury due to electrical voltage!
 The Profibus, RS-485, temperature measurement input and residual current measurement input are not galvanically isolated from each other.
It is therefore essential to note that dangerous voltages at these inputs can have an effect on the respective other connections.

8.4 Bus structure

- All devices are connected in a bus structure (line).
- Each device has its own address within the bus (see also Programming parameters).
- Up to 32 nodes can be connected together in one segment.
- At the beginning and end of a segment, the cable must be terminated with resistors (bus termination, 120 Ω, 1/4 W).
- If there are more than 32 nodes, repeaters (line amplifiers) must be used to connect the individual segments.
- Devices with bus termination switched on must be powered.
- It is recommended that the master be placed at the end of a segment.
- If the master is replaced with the bus termination switched on, the bus is out of operation.
- If a slave with bus termination switched on is replaced or is without voltage the bus may become unstable.
- Devices that are not involved in the bus termination can be replaced without the bus becoming unstable.

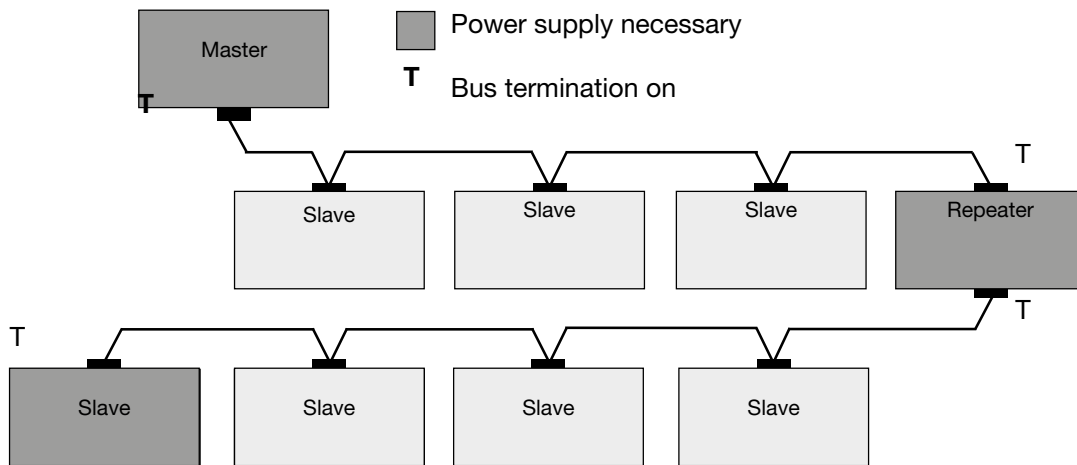

Fig. Bus structure

***i* INFORMATION**

CAT cables are not suitable for bus wiring. Use the recommended cable types for this.

8.5 Ethernet interface

The Ethernet interface is located on the bottom of the device. When connecting, make sure to provide an adequate connection area depending on the bending radius and connector type of the Ethernet cable.

This connection area should not be smaller than 50 mm.

ATTENTION

Material damage due to incorrect network settings.

Incorrect network settings can cause faults in the IT network!

Consult your network administrator for the correct network settings for your device.

ATTENTION

Material damage due to security vulnerabilities in programs, IT networks and protocols.

Security vulnerabilities can lead to data misuse and faults and even the standstill of your IT infrastructure.

To protect your IT system, network, data communications and measurement devices:

- Inform your network administrator and/or IT representative.
- Always keep the meter firmware up to date and protect the communication to the meter with an external firewall. Close unused ports.
- Take protective measures against viruses and cyber attacks from the Internet, e.g. through firewall solutions, security updates and virus protection programs.
- Close security vulnerabilities and update or renew existing protection for your IT infrastructure.

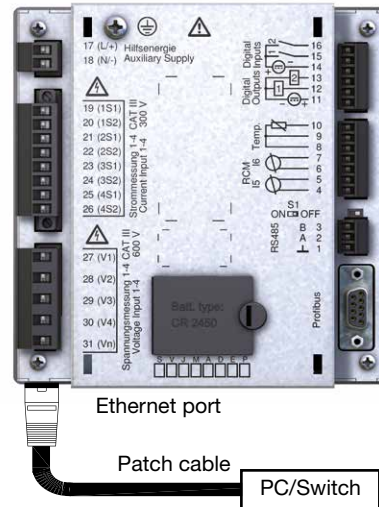

i INFORMATION

The device is set to dynamic IP address assignment at the factory (**DHCP mode**). These settings can be changed as described in „11.2.1 Ethernet (TCP/IP)“ or via the GridVis software. (see www.janitza.com)

i INFORMATION

For connecting, we recommend using at least CAT5 cable.

Meaning of the LEDs of the Ethernet interface:

LED	Function
Yellow	Blinks during network activity.
Green	Is illuminated when there is a connection (link).

9. Digital inputs and outputs

ATTENTION

Transmission error and material damage due to electrical malfunction.

With a cable length of more than 30 m, there is an increased probability of transmission errors and damage to the device due to atmospheric discharge!

Use shielded cables for the connections to the digital inputs and outputs!

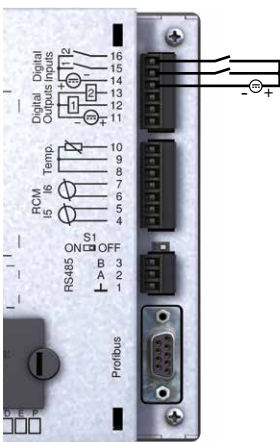

Fig. Connection of digital inputs

9.1 Digital inputs

The device has two digital inputs.

On one digital input, an input signal is recognized when a voltage of at least 18 V and at most 28 V DC (typically at 4 mA) is present.

For a voltage from 0 to 5 V and for a current of less than 0.5 mA, there is no input signal.

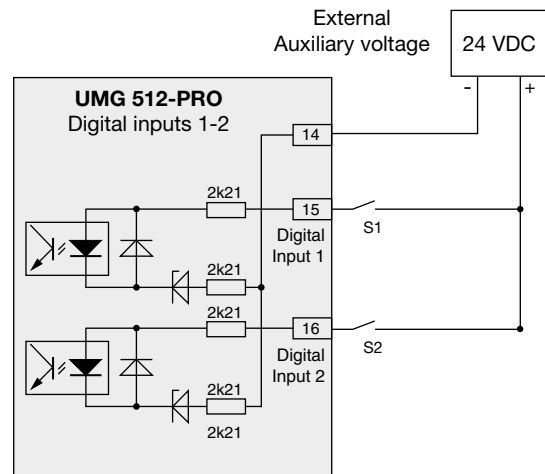

Fig. Example of connection of external contacts S1 and S2 to digital inputs 1 and 2

i INFORMATION

Observe the polarity of the supply voltage.

9.1.1 S0 pulse input

An S0 pulse generator according to DIN EN62053-31 can be connected to each digital input.

You need an external auxiliary voltage with an output voltage in the range of 18 .. 28 VDC and a resistor of 1.5 kohms.

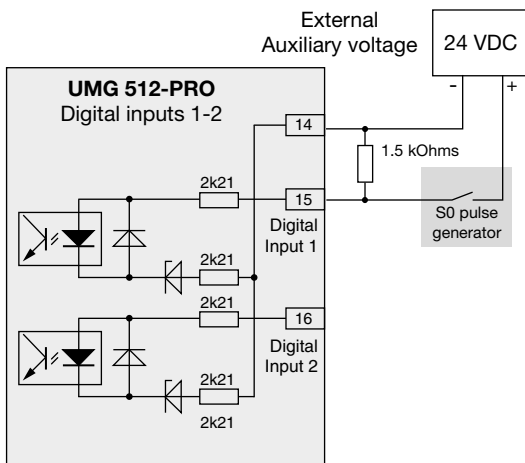

Fig. Example for the connection of an S0 pulse generator to digital input 1

9.2 Digital outputs

The device has two digital outputs that:

- Are electrically isolated from the evaluation electronics via optocouplers.
- Have a common reference.
- Require an external auxiliary voltage.
- Can be used as impulse outputs.
- Can switch DC loads.

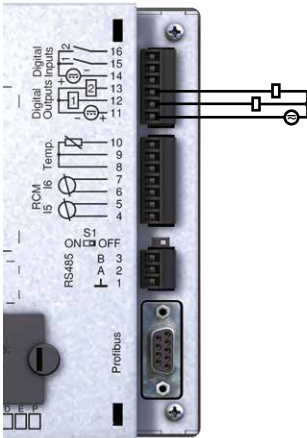

Fig. Connection of digital outputs

i INFORMATION

Functions for the digital outputs can be set with a good overview using the GridVis software (see www.janitza.com).

i INFORMATION

When using the digital outputs as pulse outputs, measurement errors can occur due to residual ripple. For the supply voltage (DC) of the digital inputs and outputs, use power supplies whose residual ripple is less than 5% of the supply voltage.

ATTENTION

Connection errors can damage the device and cause material damage.
 The digital outputs are not short-circuit proof! Connection errors can therefore lead to damage to the connections.
Make sure that the wiring is correct when connecting the outputs.

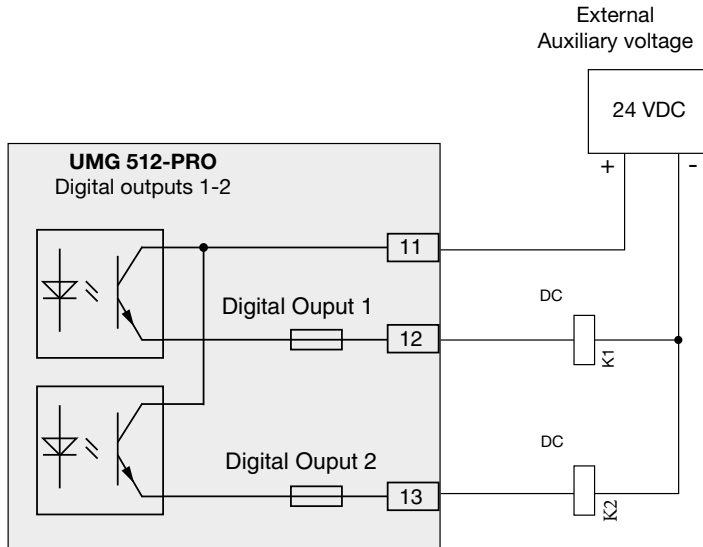

Fig. Example for connecting 2 relays to digital outputs 1 and 2

10. Operation

The device is operated via six function buttons, which are assigned different functions depending on the context:

- Selecting measuring displays.
- Navigation within the menus.
- Editing device settings.

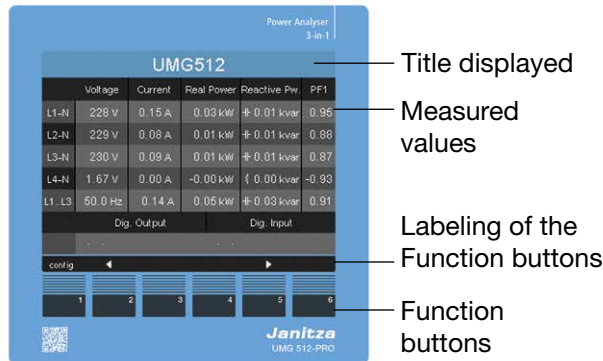

Fig. UMG 512-PRO "Home" measuring display

10.1 Button assignment

Button	Function
1	<ul style="list-style-type: none"> · Return to the first screen (Home) · Exit selection menu
2	<ul style="list-style-type: none"> · Select digit · Select main values (U, I, P ...)
3	<ul style="list-style-type: none"> · Change (digit -1). · By-values (select) · Select menu item
4	<ul style="list-style-type: none"> · Change (digit +1). · By-values (select) · Select menu item
5	<ul style="list-style-type: none"> · Select digit · Select main values (U, I, P ...)
6	<ul style="list-style-type: none"> · Open selection menu · Confirm selection

10.2 Measuring display "Home"

After a restoration of network power, the device starts with the measuring display "Home".

This measuring display contains the device name and an overview of important measured values. In the delivery condition, the device name consists of the device type and the serial number of the device.

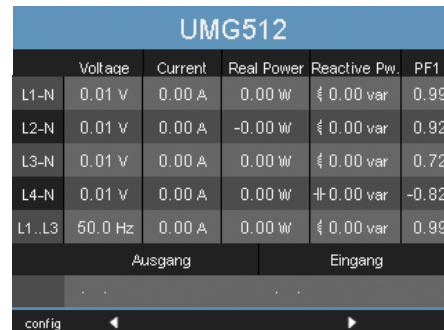

Fig. UMG 512-PRO relevant voltage VLN in a three-phase 4-conductor network

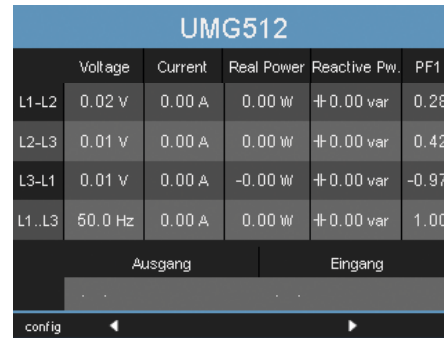

Fig. UMG 512-PRO relevant voltage VLL in a three-phase 3-conductor network

i INFORMATION

The value PF1 in the display shows the value of cos phi.

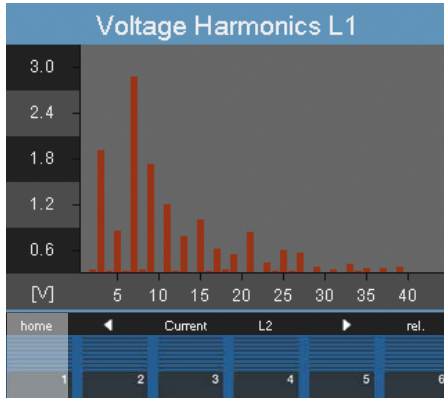

Fig. UMG 512-PRO harmonics voltage L1

The "Home - Button 1" takes you from the measuring displays for the main values directly to the first "Home" measuring display

10.3 Measuring display

10.3.1 Main values

Use buttons 2 and 5 to scroll between the main values of the measuring displays. An overview of the measuring displays can be found in the section „17.2 Overview of measuring displays“.

10.3.2 By-values

The by-values of a measuring display can be selected with buttons 3 and 4. You can also find these in the overview in the section „17.2 Overview of measuring displays“.

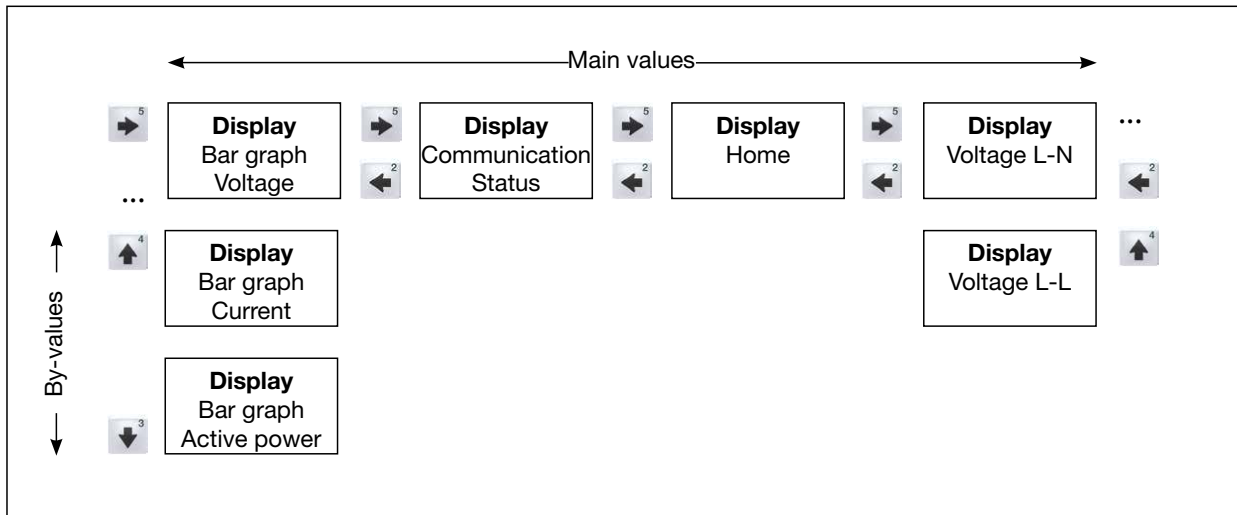

10.4 Select measuring display

To switch to a measuring display with main values, use function buttons 2 to 5 to select the desired measuring displays with main values. Function button 1 (Home) always takes you to the first measuring display.

To switch to a measuring display with by-values, proceed as follows:

1. Select the measuring display with the main values.
2. Use function buttons 3 or 4 to select the measuring display for the desired by-values.

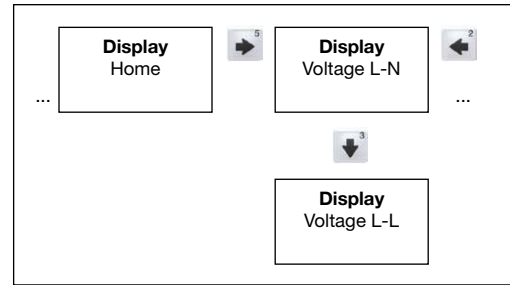

Fig. Example: Selection of voltage by-values.

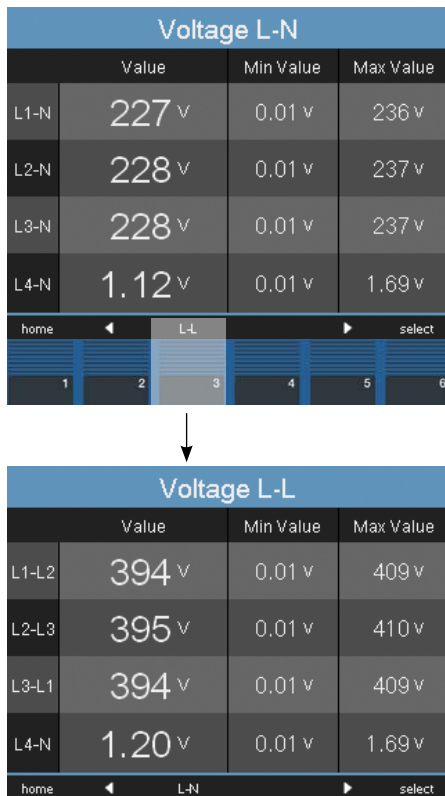

Fig. Select measuring display

10.7 Transient list

Transient voltages:

- Are fast pulse-like transient processes in electrical networks.
- Are not predictable in terms of time and are of limited duration.
- Are caused by lightning, by switching operations or by fuses blowing.

The device's transient list shows a total of 16 detected transients on 2 pages.

Proceed as follows to display a specific transient voltage:

1. Scroll to the "Transients" main value display using buttons 2 or 5
2. Select the desired page using button 4.
3. Enter the transient list using button 6 (Select).
 - The background color for date/time changes from gray to blue.
4. Select a transient with buttons 3 or 4.
5. Use button 6 (Select) to display a transient graphically.
6. Show or hide the legend by pressing button 6 (Legend) again.
7. Use button 1 (Esc) to leave the graphical display of the transient.

Transients (1..8)		
Phase	Reason	Date/Time
L4	absolut	2021 Apr 22 13:17:28,188
L3	absolut	2021 Apr 22 13:17:18,092
L2	absolut	2021 Apr 22 13:17:07,965
L1	absolut	2021 Apr 22 13:16:57,868
L4	absolut	2021 Apr 22 11:54:43,801
L3	absolut	2021 Apr 22 11:54:33,684
L2	absolut	2021 Apr 22 11:54:23,557
L1	absolut	2021 Apr 22 11:54:13,440

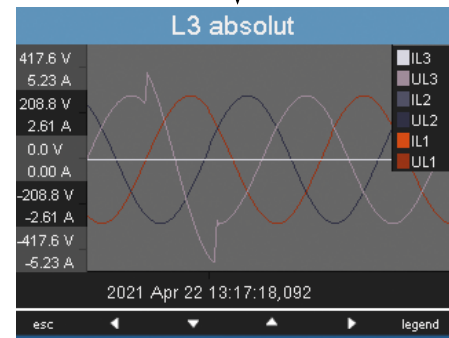

Fig. Display of a transient (VLN reference)



Fig. Display of a transient (VLL reference)

10.8 Event list

Events are limit violations of current and voltage RMS values.

The event list of your device lists a total of 16 detected events on two pages.

To display a specific event, proceed as follows:

1. Scroll to the main "Events" display using buttons 2 or 5.
2. Use button 4 to select the desired page.
3. Enter the event list with button 6 (Select).
 - The background color for date/time changes from gray to blue.
4. Use buttons 3 or 4 to select an event.
5. Press button 6 (Enter) to display the event graphically.
6. Show or hide the legend by pressing button 6 (Legend) again.
7. Use button 1 (Esc) to exit the graphical display of the event.

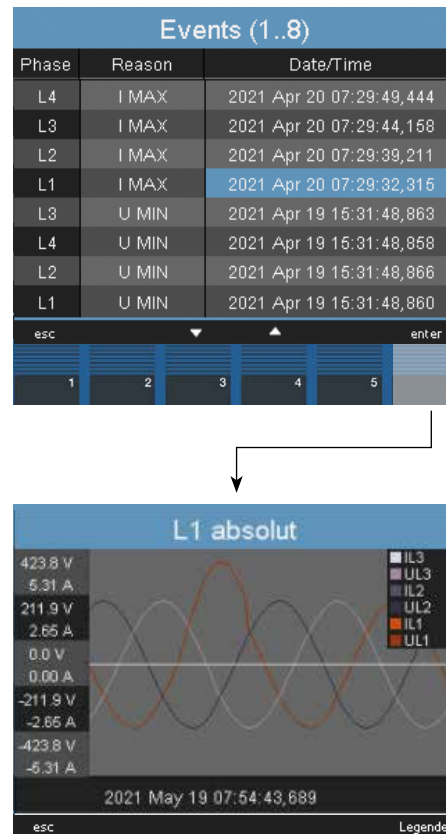

Fig. Display of an event

11. Configuration

The supply voltage must be connected to be able to configure the device. To do so, proceed as described in „12.1 Supply voltage“:

Press button 1 in the "Home" measuring display to open the configuration menu.

11.1 Languages

You can set the language for the measuring displays and menus directly in the "Configuration" menu.

There are several languages to choose from. The factory default setting for the language is "English".

Proceed as follows to change the system language:

1. Open the Configuration menu.
2. Press buttons 3 or 4 until the language field is highlighted.
3. Open the language selection with button 6 (Enter).
4. Use buttons 3 or 4 to select the desired language.
5. Confirm your selection by pressing button 6 (Enter) again.

11.2 Communication

The Communication menu can be used to configure the Ethernet and the RS-485 interface of your device.

Proceed as follows to enter the Communication menu:

1. Open the Configuration menu. By pressing button 1 in the "Home menu".
2. Press buttons 3 or 4 until the communication field is highlighted.
3. Open the "Communication" menu by pressing button 6.

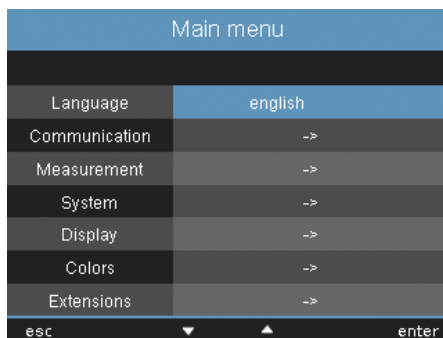

Fig. "Configuration" menu

11.2.1 Ethernet (TCP/IP)

In this section, select the address assignment mode and, if necessary, the IP address, netmask and gateway. The latter are assigned automatically in the BOOTP and DHCP assignment modes.

The device has three types of address assignment:

- **Off** - IP address, netmask and gateway are defined by you and set directly on the device. Choose this mode for simple networks with no DHCP server.
- **BOOTP** - BootP allows fully automatic integration of a device into an existing network. BOOTP is an older protocol and does not have the range of functions that DHCP does.
- **DHCP** - at startup, the device automatically obtains the IP address, netmask and gateway from a DHCP server. DHCP is pre-set at the factory.

Proceed as follows to set the IP address, netmask and gateway:

1. Press button 3 or 4 until the corresponding field is highlighted.
2. Activate the input by pressing button 6.
 - The font changes to red and a cursor appears.
3. Now set the desired digit with buttons 3 or 4.
4. Go to the next digit using button 5.
5. Repeat steps 3 and 4 until you have completed the desired input.
6. Confirm your entry with button 6.

11.2.2 Fieldbus

If you connect the device via the RS-485 interface, configure the following settings in this section:

- **Modbus protocol** - Here you select whether the device will act as a Modbus slave or Modbus master/gateway.
- **Device address** - Select a device address here for the device, with which the device can be accessed in the bus. This address must be between 0 and 255 and must be unique in the bus structure.
- **Baud rate** - Select the baud rate for all devices in a bus structure uniformly. Possible settings are 9600, 19200, 38400, 57600, 115200, 921600 kbps. The factory default setting is 115200 kbps.

Proceed as follows to make the settings:

1. Press button 3 or 4 until the corresponding field is highlighted.
2. Press button 6 (Enter) to open the selection options.
3. Use buttons 3 or 4 to select the corresponding value.
4. Confirm your selection with button 6.

ATTENTION

Material damage due to incorrect network settings.

Incorrect network settings can cause faults in the IT network!

Consult your network administrator for the correct network settings for your device.

11.3 Measurement

In the Measurement menu, configure:

- The transformers for current and voltage measurement
- The recording of transients
- The recording of events
- The "Relevant Voltage"
- The mains frequency
- The flicker settings
- The temperature sensor

The device has:

- 4 measurement channels for current measurement (I1..I4)
- 4 measurement channels for voltage measurement (V1..V4 against Vref).

The measured voltages and currents for measurement channels 1-4 must all be from the same network.

Main measurement

The main measurement includes the measurement channels 1-3. Use measurement channels 1-3 in three-phase systems.

Auxiliary input

Only measurement channel 4 belongs to the auxiliary input. Use measurement channel 4 for measurement in single-phase systems or in three-phase systems with a symmetrical load.

The settings for the frequency and the "Relevant voltage" are taken automatically from the settings for the main measurement.

Measurement	
Transformer	->
Transients	->
Events	->
Voltage mode	L-N
Rated Freq.	50 Hz (fixed frequency)
Flicker	230V/50Hz
Temperatur	PT100
esc	enter

Fig. "Measurements" menu

11.3.1 Transformers

The following settings for main and auxiliary measurements can be made here:

- Current transformer
- Voltage transformer
- Nominal current
 - Rated voltage L-N, L-L
- Connection

as well as settings for ratios and monitoring for residual current transformers.

Current transformers

You can assign current transformer ratios to the main measurement and the auxiliary measurement respectively.

For direct measurement of currents, select the 5/5 A setting.

Setting range:

Primary	1 .. 1000000
Secondary	1 .. 5

Factory default setting:

Primary	5
Secondary	5

Nominal current

The nominal current defines the reference value for the following measurements:

- Overcurrent
- Current transients
- K-factor
- Automatic scaling of graphics

Setting range: 0 .. 1000000 A

i INFORMATION

NOTE!

For Janitza measurement devices and components, use **only** current transformers intended for measuring purposes (“transformers”)!

“Transformers”, unlike “protection transformers”, go into saturation at high current peaks. “Protection transformers” do not have this saturation behavior and can therefore significantly exceed the rated values in the secondary circuit. This can overload the current measurement inputs of the measurement devices!

Furthermore, please note that Janitza measurement devices and components are **not** to be used for critical switching, control or protection applications (protective relays)! Observe the safety and warning information in the chapters „7. Installation“ and „2. Safety“!

Transformer MAIN		
	primary	secondary
Current Transf.	32 A	5 A
Voltage Transf.	400 V	400 V
Rated Current	100 A	
Rated Voltage	230 V (LN)	398 V (LL)
Apply to AUX	no	
Connection	4w3m	
esc ▼ ▲ enter		

Fig. Configuring the current transformer ratios

Voltage transformers

You can assign voltage transformer ratios to the main measurement and the auxiliary measurement respectively.

For measurements without a voltage transformer, select the 400/400 V setting.

Setting range:

Primary 1 .. 1000000
 Secondary 1 .. 999

Factory default setting:

Primary 400
 Secondary 400

Nominal voltage

The nominal voltage corresponds to the "Agreed input voltage U_{din}" according to EN 61000-4-30. The nominal voltage defines the reference point for:

- Overdeviation (EN 61000-4-30)
- Underdeviation (EN 61000-4-30)
- Transients
- Events
- Automatic scaling of graphics.
- When the nominal voltage U_{LN} is entered, the nominal voltage U_{LL} is calculated automatically.
 Formula: $U_{LL} = U_{LN} \cdot \sqrt{3}$
- When the nominal voltage U_{LL} is entered, the nominal voltage U_{LN} is calculated automatically.

$$U_{LN} = \frac{U_{LL}}{\sqrt{3}}$$

Setting range, U_{LN}: 0 .. 999999 V

Setting range, U_{LL}: 0 .. 999999 V

Factory default setting: 230 V (U_{LN}),
 398 V (U_{LL})

Transformer MAIN		
	primary	secondary
Current Transf.	32 A	5 A
Voltage Transf.	400 V	400 V
Rated Current	100 A	
Rated Voltage	230 V (LN)	398 V (LL)
Apply to AUX	no	
Connection	4w3m	

Fig. Transformer, main measurement

Apply AUX / MAIN

These settings can be set separately for the main and auxiliary measurement.

The menu item "Apply AUX / Main" allows you to apply the settings from the auxiliary or main measurement respectively, so that you do not have to enter everything again.

- **No** - The settings from the auxiliary or main measurement are not adopted.
- **Yes** - The settings from the auxiliary or main measurement are adopted.

Connection

For voltage and current measurement, you can choose between different connection schemes using the "Connection" selection (see „7.7 Connection variants“).

Factory default setting: 4w3m

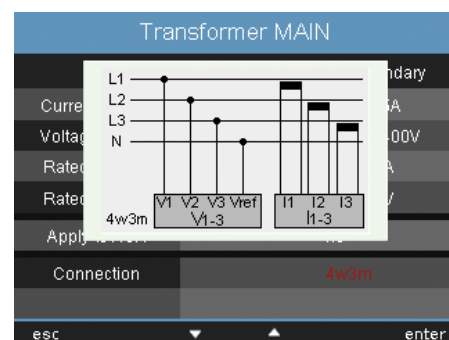

Fig. Example of measurement in a three-phase 4-conductor network with an asymmetrical load

Lock transformer ratios

The current and voltage transformer ratios can be locked/unlocked via the display. The status can be read out via an internal device address:

- If the entry "Lock all transformers" contains the value "no", the registers are **not** locked (neither current transformer (CT) nor voltage transformer (VT) ratios).
- If the entry "Lock all transformers" contains the value "yes", the registers **are locked** (CT and VT ratios).

Modbus addr.	Value/function
19716	Lock transformer ratios 0 = not locked 1 = locked

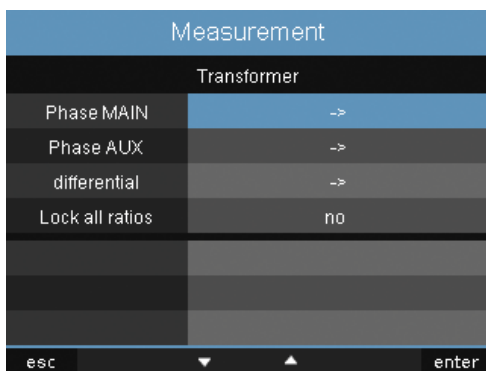

Fig. Lock transformer ratios

***i* INFORMATION**

- A Modbus address list for your device can be found in the download area at www.janitza.com.

Residual current transformer

When using the residual current inputs I5 and I6, the corresponding ratios of the residual current transformers used must be set.

Setting range:

Primary	1 .. 1000000
Secondary	1

Factory default setting:

Primary	127
Secondary	1

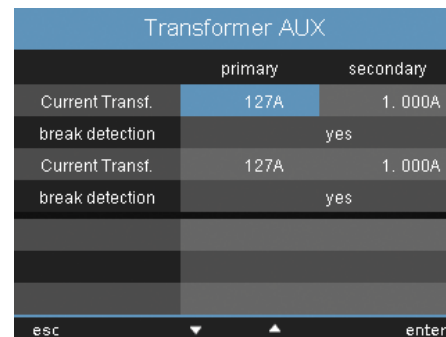

Fig. Residual current transformer menu

The failure monitoring of the corresponding residual current inputs is also set in this menu:

- **Activated** - Switches on the failure monitoring for the residual current measurement.
- **Deactivated** - Switches off the failure monitoring for the residual current measurement.

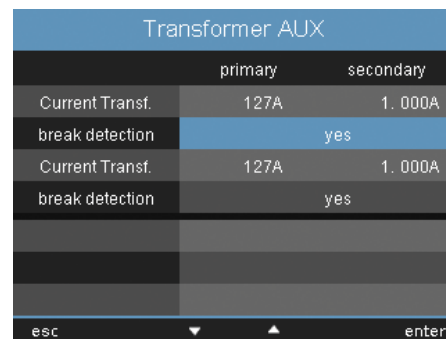

Fig. Failure monitoring

11.3.2 Transients

The device:

- Monitors the measurement inputs for transients.
- Detects transients that are longer than 39 μ s.
- Can detect transients according to two independent criteria.
- Indicates transients as a function of the set relevant voltage.

The addition of an "(LN)" or "(LL)" indicates the dependence of the calculated voltage values for the transient setting.

Measurement	
Transformer	->
Transients	->
Events	->
Voltage mode	L-L
Rated Freq.	Auto (measurement 15-440 Hz)
Flicker	230V/50Hz
Temperatur	PT100
esc ▼ ▲ enter	

Fig. Example "Relevant voltage" ULL

Allocations MAIN	
Transients	
Voltage absolute	Manual
% of nominal U	150 % 845.1 V (LL)
Voltage slope	Off
% of nominal U	
Voltage envelope	Automatic
% of nominal U	
Current absolute	Manual
% of nominal I	150 % 10.6 A
Apply to AUX	no
esc ▼ ▲ enter	

Fig. Setting MAIN "Transients" ULL

When a transient is detected:

- The waveform is stored in a transient recording.
- The limit value, both in automatic and manual mode, is automatically increased by 20 V for the next 10 minutes.
- Each further transient is recorded with 512 points for a period of 60 seconds.

You can display recorded transients using the GridVis® event browser.

The following modes are available for recording transients:

- **Absolute**
- **Delta**
- **Envelope**

Mode (absolute)

If a sample value exceeds the set limit value, a transient is detected:

- **Off** - The transient monitoring is switched off
- **Automatic** - Factory default. The limit value is calculated automatically and is 150% of the current 200 ms RMS value.
- **Manual** - The transient monitoring uses the configurable limit values under "Peak".

Mode (delta)

If the difference of two adjacent sample points exceeds the set limit value, a transient is detected:

- **Off** - The transient monitoring is switched off.
- **Automatic** - Factory default. The limit value is calculated automatically and is 0.2175 times the current 200 ms RMS value.
- **Manual** - The transient monitoring uses the configurable limit values under "Trns U".

Mode (envelope)

If a sample value is outside the range of the envelope, a transient is detected:

- **Off** - The transient monitoring is switched off
- **Automatic** - Factory default. The envelope is calculated automatically and is $\pm 15\%$ of the measured voltage.
- **Manual** - The transient monitoring uses the configurable envelope.

Apply AUX / MAIN

These settings can be set separately for the main and auxiliary measurement.

The menu item "Apply AUX / Main" allows you to apply the settings from the auxiliary or main measurement respectively, so that you do not have to enter everything again.

Monitoring of the transients can be switched off (Off/Manual).

If a transient is switched off and on again, the value is first initialized according to its defaults. Either 85%, 110% or 150% depending on the setting.

11.3.3 Events

Events are limit violations of set limit values for current and voltage.

Here, the limit values are compared with the half-wave RMS values of current and voltage from the measurement channels.

The event recording includes:

- Average value
- A minimum or maximum value
- A start time and an end time.

An event describes faults due to:

- Over-/undervoltage
- Rapid voltage changes
- Power failure (voltage loss)
- Overcurrent
- Over/under frequency
- Rapid frequency changes

Monitoring of the events can be switched off (Off/Manual).

If you switch an event off and on again, the value is first initialized according to its defaults. Either 85%, 110% or 150% depending on the setting.

Limit values and hysteresis are set on the device as a percentage of the nominal value for:

- Overvoltage and undervoltage
- Voltage interruption
- Overcurrent.

Allocations MAIN		
Events		
Under voltage	Off	
% of nominal U		
Over voltage	Manual	
% of nominal U	110 %	253.0 V (LN)
Over current	Manual	
% of nominal I	85 %	4.3 A
Apply to AUX	no	
esc ▲ ▼ enter		

Fig. Configuring an event

If an event has occurred, the associated measured value is recorded with the set lead and lag time (0..1000 half-waves each).

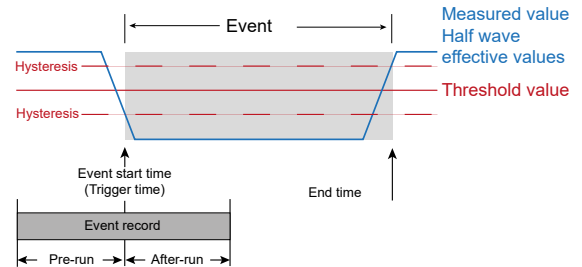

i INFORMATION

Event recording can be set with a good overview using the GridVis® software (see www.janitza.com).

i INFORMATION

The lead and lag times can only be set using the GridVis software.

Factory default setting: 0

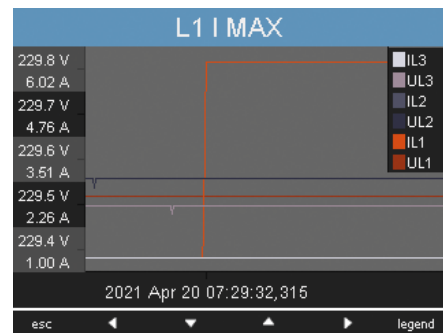

Fig. Display of an overcurrent for an event

Voltage dip

A voltage dip is set in % of the nominal voltage U_{LN} .

Overvoltage

The overvoltage is set in % of the nominal voltage U_{LN} .

Overcurrent

The rapid increase of the current is set in % of the nominal current.

Apply AUX / Main

These settings can be set separately for the main and auxiliary measurement.

The menu item "Apply AUX / Main" allows you to apply the settings from the auxiliary or main measurement respectively, so that you do not have to enter everything again.

11.3.4 Relevant voltage

Depending on the use case, the following are required for the analysis of the power quality

- The voltage between the phase conductors (L), thus **L-L**
- Or the voltage between phase conductor (L) and neutral conductor (N), **L-N**

The menu item "Relevant voltage" allows you to choose between these two settings.

The "L-N" setting is recommended for measuring the power quality in low-voltage networks. The setting "L-L" should be used in medium voltage networks.

Measurement	
Transformer	->
Transients	->
Events	->
Voltage mode	L-L
Rated Freq.	Auto (measurement 15-440 Hz)
Flicker	230V/50Hz
Temperatur	PT100
esc	enter

Fig. Setting the relevant voltage

11.3.5 Nominal frequency

The device determines the mains frequency from the applied voltage L1 and uses this for the further calculations.

The nominal frequency of the network must be set manually on the device before measurement starts. The nominal frequency is required as a reference for measuring the power quality.

Setting range for the nominal frequency:

- 50 Hz (factory default setting)
- 60 Hz
- 15 Hz .. 440 Hz (automatic)
- For measuring the power quality according to EN61000 4 30 and EN50160, select the nominal frequency of 50 Hz or 60 Hz.
- For measurements in networks with other nominal frequencies, e.g. 16 2/3 Hz or 400 Hz, set the nominal frequency to "automatic".

Measurement	
Transformer	->
Transients	->
Events	->
Voltage mode	L-N
Rated Freq.	50 Hz (fixed frequency)
Flicker	230V/50Hz
Temperatur	PT100
esc	enter

Fig. Setting the nominal frequency

***i* INFORMATION**

Automatic determination of the mains frequency requires that a voltage L1-N of greater than 10 Vrms be present at voltage measurement input V1.

***i* INFORMATION**

The flicker values can only be determined for the "Relevant voltage" L-N.

11.3.6 Flicker

The device requires the fundamental network values for the voltage and frequency-dependent measurement and calculation of the flicker values (flicker measurement according to DIN EN61000-4-15:2011). These variables must be specified by the user and can be selected from a predefined list:

- 230 V/50 Hz (factory default)
- 120 V/50 Hz
- 230 V/60 Hz
- 120 V/60 Hz

Measurement	
Transformer	->
Transients	->
Events	->
Voltage mode	L-N
Rated Freq.	50 Hz (fixed frequency)
Flicker	230V/50Hz
Temperatur	PT100

Fig. Setting the flicker values

i INFORMATION

The flicker values can only be determined for the "Relevant voltage" L-N.

11.3.7 Temperature

When using a temperature measurement, select the appropriate sensor type from a predefined list:

- PT100
- PT1000
- KTY83
- KTY84

Measurement	
Transformer	->
Transients	->
Events	->
Voltage mode	L-N
Rated Freq.	50 Hz (fixed frequency)
Flicker	230V/50Hz
Temperatur	PT100

Fig. Setting the sensor type for temperature measurement.

11.4 System

Here you can access the system settings and, as far as this is possible, change them.

System		
1	Version	5.000
2	Serial	42000678
3	MAC	00:0E:6B:09:02:A6
4	Address	195.145.150.168
5	Gateway	195.145.150.161
6	Date/Time	31.07.2017 09:34:19
7	Password	0
8	Re-initialization	->
esc ▼ ▲ enter		

Fig. System settings

- 1 Firmware version
- 2 Serial number of the device
- 3 Fixed MAC address of the device
- 4 IP address that is set
- 5 Gateway address that is set
- 6 Date and time
- 7 Password that is set
- 8 Reset settings

i INFORMATION

The settings for time synchronization, date and time can be changed via the GridVis software (see www.janitza.com).

11.4.1 Password

A password can be used to block access to the configuration. Changing the configuration directly on the device is then only possible after entering the password.

The password consists of a 6-digit number.

Setting range:

1-999999 = with password
0 = without password

The factory setting is no password (0).

To change an already set password, you must know the current password. Remember a changed password.

Proceed as follows to set a password:

1. Open the System menu.
 2. Navigate to the Password setting using buttons 3 or 4.
 3. Open the output by pressing button 6.
 4. Use buttons 2 to 5 to enter the desired password.
 5. Confirm your entry by pressing button 6 again.
- If you no longer wish to be prompted for a password, enter "0" as the password.

i INFORMATION

If you no longer know the password, you can only change it using the GridVis software (see www.janitza.com).

11.4.2 Reset

This area allows you to reset the settings that have been made to the factory defaults.

Reset energy

You can clear all energy meters in the device simultaneously. It is not possible to select specific energy meters.

1. Open the Reset menu.
2. Use buttons 3 or 4 to highlight the "Reset Energy" item (highlighted in color).
3. Activate the input by pressing button 6.
 - The font color changes to red
4. Change the value to "Yes" by pressing button 4.
5. Confirm your entry with button 6.
 - The message "Executed" appears in the line - all energy meters have been cleared.

Delete Min. / Max. values

You can delete all min. and max. values in the device at the same time.

A description of how to delete individual min. and max. values can be found in "10.6 Deleting values".

Re-initialization	
Reset energy	no
Clear min/max	no
Delivery status	no
Reset	no
esc	enter

Fig. Deleting min. / max. values

1. Open the Reset menu.
2. Use buttons 3 or 4 to select the "Min/Max values" item (highlighted in color).
3. Activate the input by pressing button 6.
 - The font color changes to red and a cursor appears.
4. Change the value to "Yes" by pressing button 4.
5. Confirm your entry with button 6.
 - The message "Executed" appears in the line - all min. and max. values have been cleared.

i INFORMATION

Before commissioning, delete any possible production-related contents of the energy meters, min./max. values and recordings.

As delivered condition

Here, all settings, such as configuration and recorded data can be reset to the factory default settings. Entered activation codes will not be deleted.

1. Open the Reset menu.
2. Use buttons 3 or 4 to highlight the "As delivered condition" item (green marking)
3. Activate the input by pressing button 6.
 - The font color changes to red and a cursor appears.
4. Change the value to "Yes" by pressing button 4.
5. Confirm your entry with button 6.
 - The message "Executed" appears in the line - the as delivered condition is restored.

Restart

Proceed as follows to restart the device manually:

1. Open the Reset menu.
2. Use buttons 3 or 4 to highlight the "Restart" item (green marking)
3. Activate the input by pressing button 6.
 - The font color changes to red and a cursor appears.
4. Change the value to "Yes" by pressing button 4.
5. Confirm your entry with button 6.
 - The device restarts within approx. 10 seconds.

11.5 Display

Here you can adjust the display settings of your device.

Brightness

Here you can set the display brightness of the device. Proceed in the same way as described in the previous chapters.

Setting range: 0 .. 100%

Factory default setting: 70%

- 0% = dark
- 100% = very bright

 INFORMATION

The backlight service life is extended when the backlight brightness is lower.

Standby

Here you can set the time after which the display brightness switches to the set standby brightness.

Setting range: 60 .. 9999 sec.

Factory default setting: 900 sec.

Brightness (standby)

Here you can set the display brightness the device switches to after the standby time has elapsed. The standby time is restarted when buttons 1-6 are used.

Setting range: 0 .. 60%

Factory default setting: 40%

Screensaver

Here you can activate or deactivate the screen-saver.

i INFORMATION

If the display shows an unchanging image over a longer period of time, this can damage the display.

Using a screensaver prevents this and thus prolongs the service life of the display.

Setting range: Yes, No
Factory default setting: Yes

Visualization

Here you can set the speed at which new measured values appear in the measuring displays. The following speeds are available:

- Fast
- Slow (200 ms)
- Slow (1 sec.)

Factory default setting: Fast

Cycle

Here you activate or deactivate the automatic switching between the different measuring displays.

Setting range: Yes, No
Factory default setting: No

Change time

Here you can set the time after which the display automatically switches to the next measuring display.

Setting range: 0 .. 255 seconds
Factory default setting: 0 seconds

11.6 Colors

Select the colors for the visualization of current and voltage in the graphical displays here.

1. Press buttons 3 or 4 until the color field is highlighted.
2. Open the Colors menu using button 6.
3. Use buttons 3 or 4 to select the desired color field.
4. Confirm your selection with button 6.
5. Use buttons 3 or 4 to select the desired color.
6. Confirm your selection by pressing button 6.

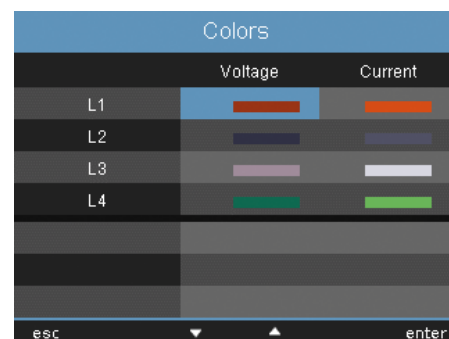

Fig. Menu setting for colors

11.7 Extensions

Here you can:

- Unlock functions later on that are subject to a charge.
- Retrieve the status of the Jasic programs.

Activation

The device contains the following functions that are subject to a charge and that can be activated later on:

- BACnet

The activation code can be obtained from the manufacturer. The manufacturer requires the serial number of the device and the name of the function to be activated.

To activate the function, enter the 6-digit activation code on the corresponding line.

Note that the activation code is only valid for one device.



Fig. Menu setting for extensions

Jasic status

Up to 7 customer-specific Jasic programs (1-7) and one recording can run in the device.

The Jasic programs can assume the following states:

- Stopped
- Running

Extensions	
	Jasic-state
Jasic-state 1	running
Jasic-state 2	running
Jasic-state 3	running
Jasic-state 4	running
Jasic-state 5	running
Jasic-state 6	running
Jasic-state 7	stopped
Records	running
esc	

Fig. Menu setting for Jasic status

i INFORMATION

The status of Jasic programs can only be changed through the software.

11.8 PTP configuration

The device supports the **Precision Time Protocol (PTP)** in accordance with the Standard Annex J IEEE 1588-2008 **PTP Default Profile**.

The PTP protocol is executed in a logical area known as the domain. The time specified by the protocol in one domain is independent of the times in other domains.

The PTP protocol enables precise time synchronization in the network from the time server (master) to the clients (slaves). The prerequisite for this is the PTP capability of the client. The reference time for the system is determined by what is known as the Grandmaster Clock (see the section „11.8.3 Example: PTP timing according to IEEE 1588-2008 and clock types“)

Time synchronization in a network is achieved by the exchange of PTP time control messages. Clients use the time control information in the PTP messages to set their time to that of the time server (master) in their part of the hierarchy.

While NTP uses the client-server model – each client must be configured with a name or the IP address – the system configures itself according to the default PTP profile.

For the **Device** (as of firmware version 5.017), activate PTP (or NTP):

- In the GridVis ® software (device configuration).
- Via the parameter **_MODE_NTP** (the Modbus address can be found in the Modbus address list of your device at www.janitza.com).

11.8.1 Important Modbus parameters for the PTP configuration of the device

Meanings of the Modbus parameters:

Parameter name	Data type	Permission	Entry (range)
_MODE_NTP (refer to section „11.8.2 PTP parameter _MODE_NTP“)	int	RD/WR	NTP/PTP activation
_PTP_DOMAIN ¹⁾	byte	RD/WR	Default = 0 (0 - 127)
_PTP_ANNOUNCE_RECEIPT_TIMEOUT ²⁾	byte	RD/WR	Default = 3 (2 - 10)
_PTP_MANAGEMENT_INTERFACE ³⁾	short	RD/WR	Default = 0 (0 - 1)

- 1.Domain number (default domain = 0). A PTP domain is a range of PTP clocks (devices) which synchronize themselves with each other using the PTP protocol.
- 2.Selects the PTP Announce Receipt Timeout. This parameter specifies the number of intervals that are allowed to elapse without receipt of an announce message (default = 3).
- 3.0 (default) – Device supports PTP configuration via the Modbus.
 - 1 - Alternative method of configuration (enables a comprehensive configuration via the interface).

11.8.2 PTP parameter _MODE_NTP

In this context, the entries have the following functions:

Parameter _MODE_NTP	Entry	Description
TIME_PROTOCOL_NONE	= 0	No time protocol is active. Manual time configuration.
TIME_PROTOCOL_NTP_BROADCAST	= 1	NTP mode “Listen”, PTP deactivated.
TIME_PROTOCOL_NTP_ACTIVE	= 2	NTP mode “Active”, PTP deactivated.
TIME_PROTOCOL_PTP	= 3	PTP mode is activated, NTP deactivated.

i INFORMATION

- A Modbus address list including all the PTP parameters of your device can be found in the download area at www.janitza.com.
- Specifications for PTP (Precision Time Protocol) can be found in IEEE Standard for a Precision Clock Synchronization Protocol for Networked Measurement and Control Systems (IEEE Std. 1588-2008).
- The device supports PTP according to the default PTP profile Annex J IEEE 1588-2008 with the profile ID 00-1B-19-00-01-00.

11.8.3 Example: PTP timing according to IEEE 1588-2008 and clock types

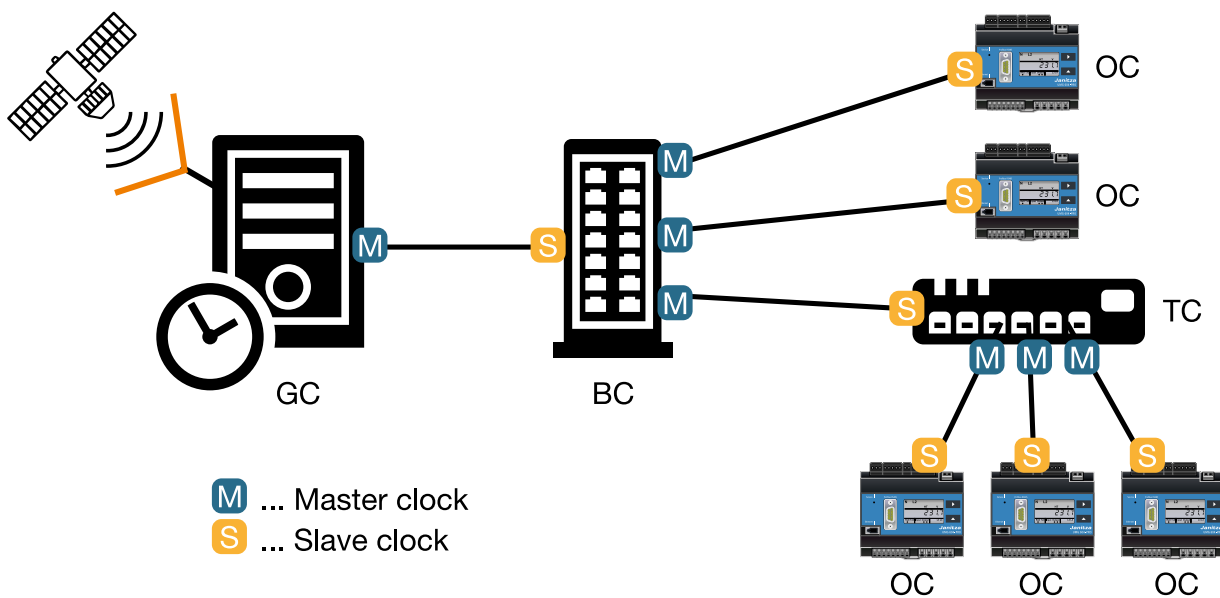

Ordinary clock (OC)	Simple clock (one port, measures one client) that is connected with a master as the slave and synchronizes its time with the master.
Boundary clock (BC)	Clock that contains several “ordinary clocks” (several ports) and, as the master, synchronizes several slaves with its time and transports this beyond a network boundary. The “boundary clock” can also be connected to a master as a slave and synchronize its time with the master.
Transparent clock (TC)	Clock that does not actively intervene in the time synchronization; it is more a hardware item that transmits time synchronization data packets (e.g. a network switch). “Transparent clocks” can also correct the time stamp within the data packet by the dwell time within the hardware, if needed.
Grandmaster clock (GC)	The grandmaster clock is an “ordinary clock” that has access to GPS or another very accurate time and provides this time for all subordinate nodes.

12. Commissioning

In this section you will learn everything needed for the initial commissioning of your device.

12.1 Supply voltage

Proceed as follows when applying the supply voltage:

1. Connect the supply voltage with a terminal on the back of the device.
2. After connecting the supply voltage, the first measuring display "Home" appears on the display after approx. 15 seconds.
3. If no display appears, check whether the supply voltage is within the nominal voltage range.



WARNING

Material damage due to disregard of the connection instructions!

Voltages and currents outside the permissible measuring range can destroy the device.

- **Comply with the measuring range specifications from the technical data.**
- **Do not use the device for measuring DC voltage!**



INFORMATION

Before commissioning, delete any possible production-related contents of the energy meters, minimum and maximum values and records.

12.2 Measured voltage

Connect voltage measurements in networks with nominal voltages above 500 VAC to ground using voltage transformers.

Proceed as follows to connect the measured voltage:

1. Connect the measured voltage using a terminal on the back of the device.
2. After the measured voltage is connected, the measured values displayed by the device for the voltages L-N and L-L must match those at the measurement input.
3. Take into account any voltage transformer factors that may be set.



WARNING

Risk of injury due to electrical voltage!

If the device is exposed to surge voltages above the permissible overvoltage category, safety-relevant areas of insulation in the device can be damaged. This means that the safety of the product can no longer be guaranteed.

Only use the device in environments in which the permissible overvoltage category is not exceeded.

12.3 Frequency measurement

For the measurement, the device requires the mains frequency, which can either be specified by the user or determined automatically by the device.

- Automatic determination of the frequency requires that a voltage (V_{Vref}) greater than 10 Vrms must be present on at least one of the voltage measurement inputs.
- The mains frequency must be in the range from 15 Hz to 440 Hz.
- If the measured voltage is not sufficiently high, the device cannot determine the mains frequency and therefore cannot carry out a measurement.

12.4 Direction of rotary field

Check the direction of the voltage rotating field in the measuring display of the device. Usually it is a "right" rotating field.

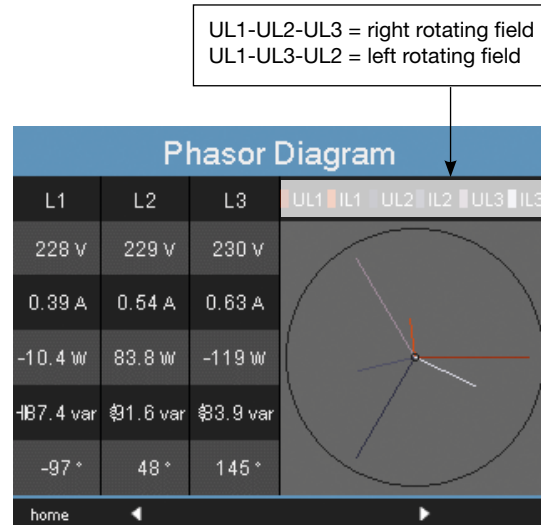

Fig. Illustration of the phase sequence according to the direction of the rotary field.

12.5 Measured current

The device:

- Is designed for the connection of current transformers with secondary currents of ≈ 1 A and ≈ 5 A.
- Does not measure DC currents.
- Has current measurement inputs which can be loaded with 120 A for 1 second.

The factory-set current transformer ratio is 5/5 A and must be adapted as needed for the current transformers used.

Proceed as follows to connect the measured current:

1. Short-circuit all current transformer outputs except one.
2. Connect the measured current via the terminal on the back of the device and secure it sufficiently with the two screws.
3. Compare the current displayed on the device with the applied input current.
 - The currents must match after taking the current transformer ratio into account.
 - At the short-circuited current measurement inputs, the device must indicate approx. 0 amperes.

Sign of phase shift angle (U/I):

- Positive (+) with capacitive load.
- Negative (-) with inductive load.

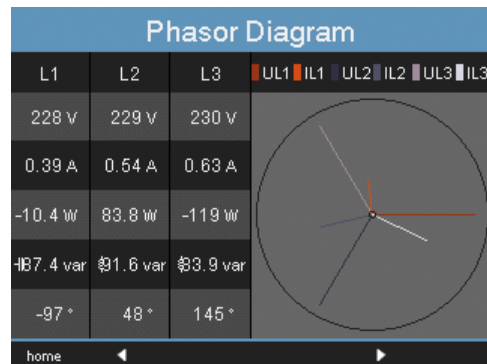
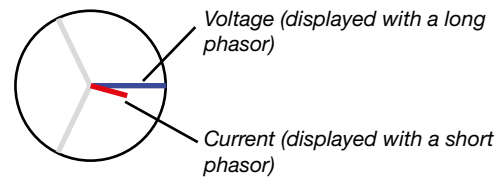

Fig. Phasor diagram



! WARNING

Material damage due to disregard of the connection instructions!
 Voltages and currents outside the permissible measuring range can destroy the device.
Comply with the measuring range specifications from the technical data.

12.5.1 Phasor diagram examples

Here are two examples showing a visualization of measured current and measured voltage in the phasor diagram:

Example 1

Primarily ohmic load.

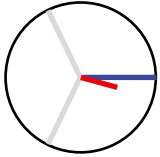

Voltage and current have only a small deviation in the phase position.

- The current measurement input is assigned to the correct voltage measurement input

Example 2

Primarily ohmic load.

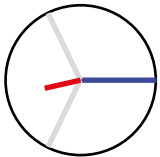

Voltage and current have a deviation of about 180° in the phase position.

- The measured current input is assigned to the correct voltage measurement input.
- In the current measurement under consideration, the connections k and l are reversed or there is a feedback into the supply network.

12.6 Residual current

Only connect residual current transformers with a nominal current of 30 mA to inputs I5 and I6!

Both residual current inputs can measure AC currents and pulsating DC currents.

The residual current displayed by the device must match the input current, taking into account the current transformer ratio.

The current transformer ratio is set to 127/1 A at the factory and may need to be adapted to the residual current transformers that are used.

i INFORMATION

- No connection diagram needs to be configured for measurement inputs I5 and I6!
-

i INFORMATION

The device requires the mains frequency to be able to measure residual currents. For this purpose, apply the measured voltage or set a fixed frequency.

12.7 Failure monitoring (RCM)

The device enables continuous monitoring of the connection to the residual current transformer for inputs I5 and I6.

Failure monitoring can be activated via:

- The corresponding menu item, as described in the section „11.3.1 Transformers“.
- Or by setting the addresses 13793 for the residual current measurement input I5 and 13795 for I6.

If there is an interruption in the connection to the current transformer, this status is recorded in specific registers or is displayed in the GridVis software.

Modbus addr.	Value/function
13797 (I5) 13799 (I6)	Failure monitoring for I5 / I6 0 = Disable monitoring 1 = Enable monitoring

Modbus addr.	Value/function
13809 (I5) 13810 (I6)	0 = Connection to the residual current transformer at I5 or I6 is fault-free 1 = Fault within the current transformer connection at I5 or I6

12.7.1 Alarm status

Using bitwise coding within the alarm registers (addr. 13925 for I5, 13926 for I6), it is possible to read out different alarm states:

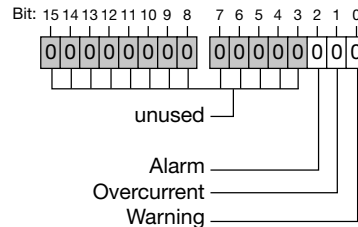

Fig. Alarm registers

Example:

An overcurrent was measured. The alarm bit is set as well and must be acknowledged!

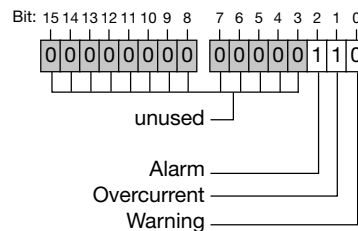

Fig. Example, alarm register in the event of measured overcurrent.

Warning:	The residual current has exceeded the set warning limit value
Overcurrent:	An overrange is present
Alarm:	The alarm bit is set in the event of a warning or overcurrent. The alarm bit must be reset or acknowledged manually.

12.8 Overrange

The overrange message is displayed as long as the condition is present and cannot be acknowledged. The measuring range is exceeded if at least one of the voltage or current measurement inputs lies outside its specified measuring range.

Limit values for overrange (200 ms effective values):

I = 8.5 Arms
UL-N = 600 Vrms

Error - Overload		
	Voltage	Current
L1	225.5 V	0.0 A
L2	EEEE	0.0 A
L3	225.4 V	0.0 A
L4	0.5 V	EEEE

Fig. Display of overrange in voltage circuit L2 and current path I4

12.9 Control of the power measurement

1. Short-circuit all current transformer outputs except one.
2. Check the displayed powers.
 - The device must only display one power in the phase with the current transformer input that is not short-circuited.
 - If this is not the case, check the connection of the measured voltage and measured current.

If the amount of active power is correct, but the sign of the active power is negative, this can have two causes:

1. The connections S1(k) and S2(l) on the current transformer are reversed.
2. Active energy is returned to the grid.

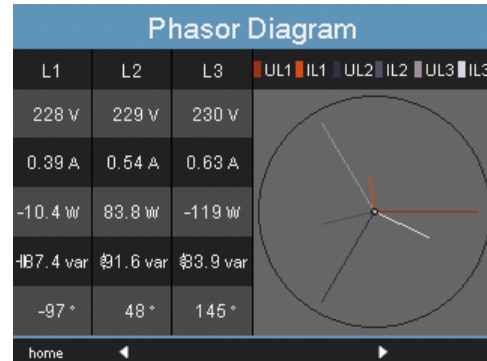

Fig. In the phasor diagram, voltages are shown with long phasors and currents with shorter phasors.

12.10 Control of the communication

The device counts all received (RX), all sent (TX) and all faulty data packets.

Ideally, the number of faults displayed in the Fault column is zero.

Pressing button 6 resets the counters for the data packets to 0. The start time for the new count is automatically reset.

Communication State			
	RX	TX	Error
Ethernet	7121.0 k	8416.4 k	461834
RS485	0	1	1
NTP	37	0	0
DHCP	35	35	0
DNS	336	335	1
E-Mail	-	0	0
Start Time	13-07-2017 19:22:49		

Fig. Communication status

12.11 Communication in the bus system

12.11.1 RS-485

The data from the parameter and measurement list can be accessed via the MODBUS RTU protocol with CRC check at the RS-485 interface (see „11.2.2 Fieldbus“).

Modbus functions (master)

- 01 Read Coil Status
- 02 Read Input Status
- 03 Read Holding Registers
- 04 Read Input Registers
- 05 Force Single Coil
- 06 Preset Single Register
- 15 (0F Hex) Force Multiple Coils
- 16 (10Hex) Preset Multiple Registers
- 23 (17Hex) Read/Write 4X Registers

Modbus functions (slave)

- 03 Read Holding Registers
- 04 Read Input Registers
- 06 Preset Single Register
- 16 (10Hex) Preset Multiple Registers
- 23 (17Hex) Read/Write 4X Registers

The order of the bytes is high before low byte (Motorola format).

Transmission parameters

- Data bits: 8
- Parity: none
- Stop bits (UMG 512-PRO): 2
- External stop bits: 1 or 2

Number formats

- short 16 bit ($-2^{15} .. 2^{15} - 1$)
- float 32 bit (IEEE 754)

 INFORMATION

Broadcast (address 0) is not supported by the device.

 INFORMATION

The telegram length must not exceed 256 bytes.

Example: Reading the voltage L1-N

The voltage L1-N is stored in the measurement list under the address 19000. The voltage L1-N is in the FLOAT format.

In this example 01 is assumed as the device address.

The "Query Message" then looks as follows:

Designation	Hex	Comment
Device address	01	Address=1
Function	03	"Read Holding Reg"
Start address Hi	4A	19000dec = 4A38hex
Start address Lo	38	
No. of values Hi	00	2dec = 0002hex
No. of values Lo	02	
Error check (CRC)	-	

The "Response" of the device can then look as follows:

Designation	Hex	Comment
Device address	01	Address=1
Function	03	
Byte counter	06	
Data	00	00hex=00dec
Data	E6	E6hex=230dec
Error check (CRC)	-	

The voltage L1-N read out from address 19000 is 230 V.

12.11.2 Profibus

Profibus profiles

A Profibus profile contains the data to be exchanged between a UMG and a PLC. Four Profibus profiles are preconfigured at the factory.

Using a Profibus profile you can:

- Retrieve measured values from the UMG,
- Set the digital outputs in the UMG,
- Query the status of the digital inputs in the UMG.

Each Profibus profile can contain a maximum of 127 bytes of data. If more data needs to be transmitted, you can create further Profibus profiles.

Each Profibus profile has a profile number, which is sent from the PLC to the UMG.

With the GridVis® software, you can directly edit 16 Profibus profiles (profile numbers 0..15). You can create additional Profibus profiles (profile numbers 16..255) via Jasic programs.

Factory preconfigured Profibus profiles can be modified later on.

Device master file

The device master file, abbreviated GSD file, describes the Profibus properties of the UMG. The GSD file is required by the configuration program of the PLC.

The device master file for your device has the file name "JANOEDC.GSD" and is available on the Janitza homepage.

Variable definition

All system variables and global variables¹⁾ can be scaled individually and converted to one of the following formats:

- 8, 16, 32-bit signed or unsigned integer.
- 32 or 64-bit floating format.
- Big Endian = High byte before low byte.
- Little Endian = Low byte before high byte.

¹⁾ Global variables are defined by the user in Jasic and are available to every interface in the device.

Example: Retrieving measured values via Profibus

You must define at least one Profibus profile with the GridVis software and transfer it to the device.

A Jasic program is not required.

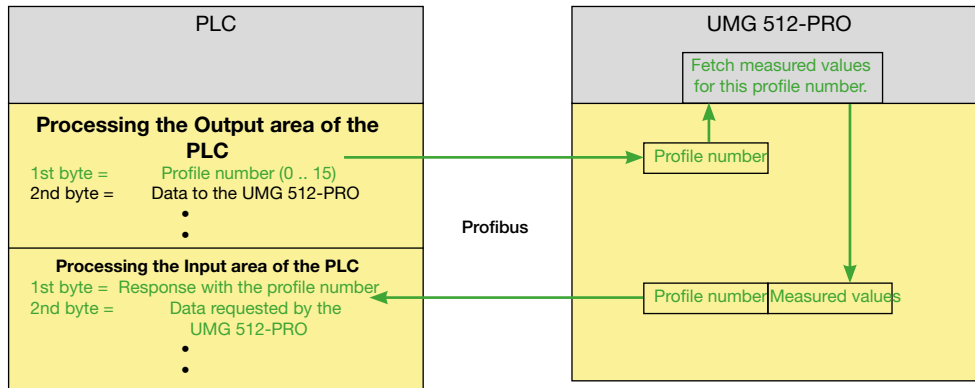

Fig. Block diagram for data exchange between PLC and UMG 512-PRO.

Factory set preconfigured profiles

This section presents a tabular representation of the preconfigured Profibus profiles

Profibus profile number 0

	Byte index	Value type	Value format	Scaling
1	1	Voltage L1-N	Float	1
2	5	Voltage L2-N	Float	1
3	9	Voltage L3-N	Float	1
4	13	Voltage L4-N	Float	1
5	17	Voltage L2-L1	Float	1
6	21	Voltage L3-L2	Float	1
7	25	Voltage L1-L3	Float	1
8	29	Current L1	Float	1
9	33	Current L2	Float	1
10	37	Current L3	Float	1
11	41	Current L4	Float	1
12	45	Active power L1	Float	1
13	49	Active power L2	Float	1
14	53	Active power L3	Float	1
15	57	Active power L4	Float	1
16	61	Cos phi (math.) L1	Float	1
17	65	Cos phi (math.) L2	Float	1
18	69	Cos phi (math.) L3	Float	1
19	73	Cos phi (math.) L4	Float	1
20	77	Frequency	Float	1
21	81	Active power, sum L1-L4	Float	1
22	85	Reactive power, sum L1-L4	Float	1
23	89	Apparent power, sum L1-L4	Float	1
24	93	Cos phi (math.) Sum L1-L4	Float	1
25	97	Effective current, sum L1-L4	Float	1
26	101	Active energy, sum L1-L4	Float	1
27	105	Ind. reactive energy, sum L1-L4	Float	1
28	109	THD, voltage L1	Float	1
29	113	THD, voltage L2	Float	1
30	117	THD, voltage L3	Float	1

Profibus profile number 1

	Byte index	Value type	Value format	Scaling
1	1	Voltage L1-N	Float	1
2	5	Voltage L2-N	Float	1
3	9	Voltage L3-N	Float	1
4	13	Voltage L2-L1	Float	1
5	17	Voltage L3-L2	Float	1
6	21	Voltage L1-L3	Float	1
7	25	Current L1	Float	1
8	29	Current L2	Float	1
9	33	Current L3	Float	1
10	37	Active power L1	Float	1
11	41	Active power L2	Float	1
12	45	Active power L3	Float	1
13	49	Cos phi (math.) L1	Float	1
14	53	Cos phi (math.) L2	Float	1
15	57	Cos phi (math.) L3	Float	1
16	61	Frequency	Float	1
17	65	Active power, sum L1-L3	Float	1
18	69	Reactive power, sum L1-L3	Float	1
19	73	Apparent power, sum L1-L3	Float	1
20	77	Cos phi (math.) Sum L1-L3	Float	1
21	81	Effective current, sum L1-L3	Float	1
22	85	Active energy, sum L1-L3	Float	1
23	89	Ind. reactive energy, sum L1-L3	Float	1
24	93	THD, voltage L1	Float	1
25	97	THD, voltage L2	Float	1
26	101	THD, voltage L3	Float	1
27	105	THD current L1	Float	1
28	109	THD current L2	Float	1
29	113	THD current L3	Float	1

Profibus profile number 2

Byte index	Value type	Value format	Scaling
1	Active energy, sum L1-L3	Float	1
2	Consumed active energy, sum L1-L3	Float	1
3	Supplied active energy, sum L1-L3	Float	1
4	Reactive energy, sum L1-L3	Float	1
5	Ind. reactive energy, sum L1-L3	Float	1
6	Cap. reactive energy, sum L1-L3	Float	1
7	Apparent energy, sum L1-L3	Float	1
8	Active energy L1	Float	1
9	Active energy L2	Float	1
10	Active energy L3	Float	1
11	Inductive reactive energy L1	Float	1
12	Inductive reactive energy L2	Float	1
13	Inductive reactive energy L3	Float	1

Profibus profile number 3

Byte index	Value type	Value format	Scaling
1	Active power L1	Float	1
2	Active power L2	Float	1
3	Active power L3	Float	1
4	Active power, sum L1-L3	Float	1
5	Current L1	Float	1
6	Current L2	Float	1
7	Current L3	Float	1
8	Current, sum L1-L3	Float	1
9	Active energy, sum L1-L3	Float	1
10	Cos phi (math.) L1	Float	1
11	Cos phi (math.) L2	Float	1
12	Cos phi (math.) L3	Float	1
13	Cos phi (math.) Sum L1-L3	Float	1
14	Reactive power L1	Float	1
15	Reactive power L2	Float	1
16	Reactive power L3	Float	1
17	Reactive power, sum L1-L3	Float	1
18	Apparent power L1	Float	1
19	Apparent power L2	Float	1
20	Apparent power L3	Float	1
21	Apparent power, sum L1-L3	Float	1

12.12 Recording configuration

Six recording profiles are preconfigured in the factory default setting of the device.

The adaptation and expansion of recordings can be done using the GridVis software.

Pro-file	Measured value	Time base	Type
1	Standard frequency	10 sec.	Sample
2	Short-term flicker, L1, L2, L3, L4	10 min.	Sample
3	Long-term flicker, L1, L2, L3, L4	2 hrs.	Sample
4	Effective voltage L1, L2, L3, L4, L1-L2, L2-L3, L3-L1	10 min.	Average value (RMS), Min./max. values
4	THD voltage L1, L2, L3, L4, L1-L2, L2-L3, L3-L1	10 min.	Average value (RMS), Min./max. values
4	Voltage harmonics (up to 25th) L1, L2, L3, L4, L1-L2, L2-L3, L3-L1	10 min.	Average value (RMS), Min./max. values
4	Voltage imbalance	10 min.	Average value (RMS), Min./max. values
5	Consumed active energy L1, L2, L3, L4	1 hr.	Sample
5	Consumed active energy, sum L1..L3, L1..L4	1 hr.	Sample
5	Apparent energy, L1, L2, L3, L4	1 hr.	Sample
5	Apparent energy, sum L1..L3, L1..L4	1 hr.	Sample
5	Reactive energy, L1, L2, L3, L4	1 hr.	Sample
5	Reactive energy, sum L1..L3, L1..L4	1 hr.	Sample
5	Inductive reactive energy, L1, L2, L3, L4	1 hr.	Sample
5	Inductive reactive energy, sum L1..L3, L1..L4	1 hr.	Sample

Profile	Measured value	Time base	Type
6	Effective current, L1, L2, L3, L4	10 min.	Average value (arithmetic), Min./max. values
6	Effective current, sum L1..L3, L1..L4	10 min.	Average value (arithmetic), Min./max. values
6	Active power, L1, L2, L3, L4	10 min.	Average value (arithmetic), Min./max. values
6	Active power, sum L1..L3, L1..L4	10 min.	Average value (arithmetic), Min./max. values
6	Apparent power, L1, L2, L3, L4	10 min.	Average value (arithmetic), Min./max. values
6	Apparent power, sum L1..L3, L1..L4	10 min.	Average value (arithmetic), Min./max. values
6	cos(phi), math. L1, L2, L3, L4	10 min.	Average value (arithmetic), Min./max. values
6	cos(phi), math. Sum L1..L3, L1..L4	10 min.	Average value (arithmetic), Min./max. values
6	Reactive power, fundamental oscillation, L1, L2, L3, L4	10 min.	Average value (arithmetic), Min./max. values
6	Reactive power, fundamental oscillation, sum L1..L3, L1..L4	10 min.	Average value (arithmetic), Min./max. values

12.13 Digital inputs/outputs

Your device has two digital outputs and two digital inputs.

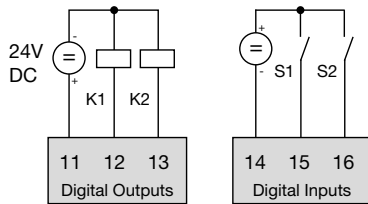

Fig.: Digital outputs and inputs

The inputs and outputs can be configured using the GridVis® software included in the scope of delivery.

12.13.1 Digital inputs

The digital inputs provide the option of sending information from other devices that have a digital output directly to your device.

The Inputs area in the configuration window of the GridVis software can be used to define the following for both digital inputs:

- Which value type the incoming signal has.
- Which scaling factor should be used for the value.

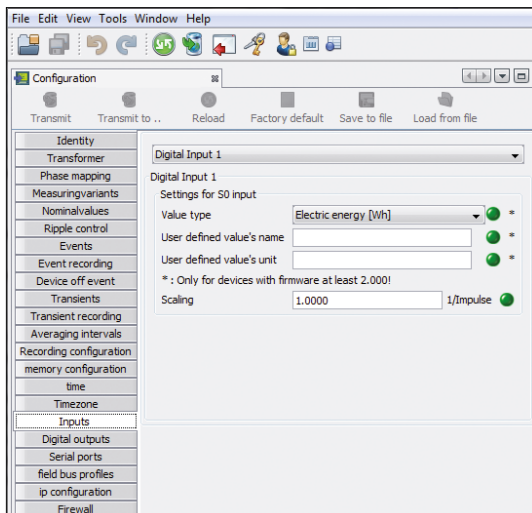

Fig. Configuring inputs of the UMG 512-PRO via GridVis.

12.13.2 Pulse output

The digital outputs can also be used to output pulses for counting energy consumption. To do so, a pulse is applied to the output after a certain, configurable amount of energy of a defined duration has been reached.

To use a digital output as a pulse output requires that various settings be made in the configuration menu using the GridVis software:

- Pulse width
- Digital output to be configured,
- Output type (event message or S0 output)
- The measured value to be transmitted
- Pulse valency

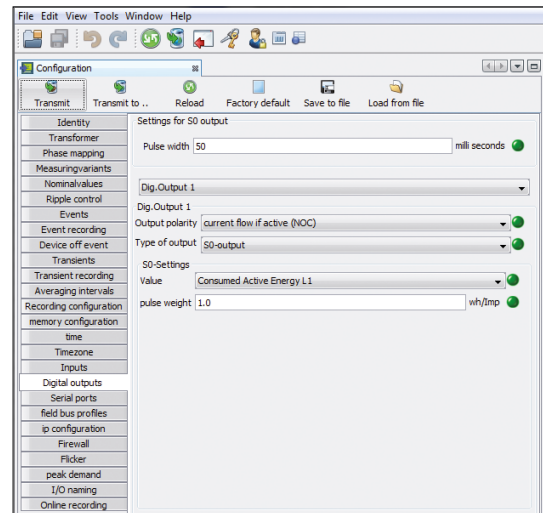

Fig. Configuring digital outputs of the UMG 512-PRO via GridVis.

Pulse length

The pulse length is valid for both pulse outputs and must be set via the GridVis software.

The typical pulse duration for S0 pulses is 30 ms.

Pulse pause

The pulse pause must be at least as large as the selected pulse length.

The pulse pause depends on the measured energy, for example, and can be hours or days.

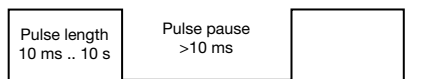

Fig. Schematic representation of a digital pulse

The values in the table for the maximum number of pulses per hour result from the minimum pulse length and the minimum pulse pause.

Pulse length	Pulse pause	Max. pulses/h
10 ms	10 ms	180,000 pulses/h
30 ms	30 ms	60,000 pulses/h
50 ms	50 ms	36,000 pulses/h
100 ms	100 ms	18,000 pulses/h
500 ms	500 ms	3,600 pulses/h
1 s	1 s	1,800 pulses/h
10 s	10 s	180 pulses/h

Tab. Examples of the maximum possible number of pulses per hour

***i* INFORMATION**

The pulse interval is proportional to the power within the selected settings.

***i* INFORMATION**

When programming with GridVis, you are given a selection of work values derived from the power values (see www.janitza.com).

Pulse valency

The pulse valency specifies how much energy (Wh or varh) should correspond to one pulse.

The pulse valency is determined by the maximum connected load and the maximum number of pulses per hour.

If you indicate the pulse valency with:

- With a positive sign, pulses are only output if the measured value also has a positive sign.
- With a negative sign, pulses are only output if the measured value also has a negative sign.

***i* INFORMATION**

Since the active energy meter operates with a reverse running stop, the device only sends pulses when electrical energy is consumed.

***i* INFORMATION**

Since the reactive energy meter operates with a reverse running stop, the device only sends pulses when there is an inductive load.

Determining pulse valency

1. Set the pulse length according to the requirements of the connected pulse receiver. With a pulse length of 30 ms, for example, the device can emit a maximum of 60,000 pulses (see table „Tab. Examples of the maximum possible number of pulses per hour“) per hour.

2. Determine the maximum connected load.

Example:

Current transformer = 150/5 A
 Voltage L-N = max. 300 V

Power per phase = 150 A x 300 V
 = 45 kW

Power with 3 phases = 45 kW x 3
 Max. connected load = 135 kW

3. Calculate the pulse valency:

$$\text{Pulse valency} = \frac{\text{Max. connected load}}{\text{Max. number of pulses/h}} \quad [\text{Wh/pulse}]$$

Pulse valency = 135 kW / 60,000 pulses/h
 Pulse valency = 0.00225 kWh/pulse
 Pulse valency = 2.25 Wh/pulse

ⓘ INFORMATION

When using the digital outputs as pulse outputs, measurement errors can occur due to residual ripple. **For the supply voltage (DC) of the digital inputs and outputs, use power supplies whose residual ripple is less than 5% of the supply voltage.**

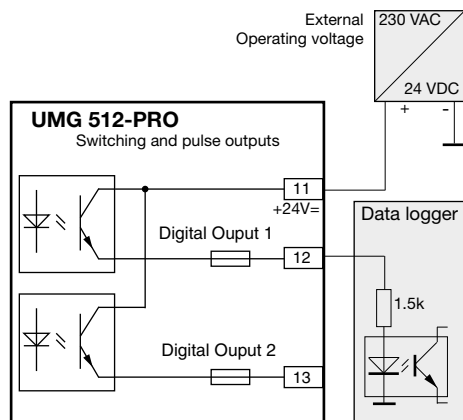

Fig.: Connection example for wiring as a pulse output.

13. Device homepage

Your meter has a built-in web server that has a standalone homepage. This device homepage allows you to access your meter with a conventional web browser from any end device. You can reach the homepage of your device by entering the IP address of the device into a web browser on your end device. A description of how to connect the device to the Internet can be found in the section „11.2.1 Ethernet (TCP/IP)“.

Here, without prior software installation, you can:

- Retrieve historical as well as current measured values.
- Retrieve the power quality status in an easy-to-understand display.
- Remotely control your device.
- Access installed apps.

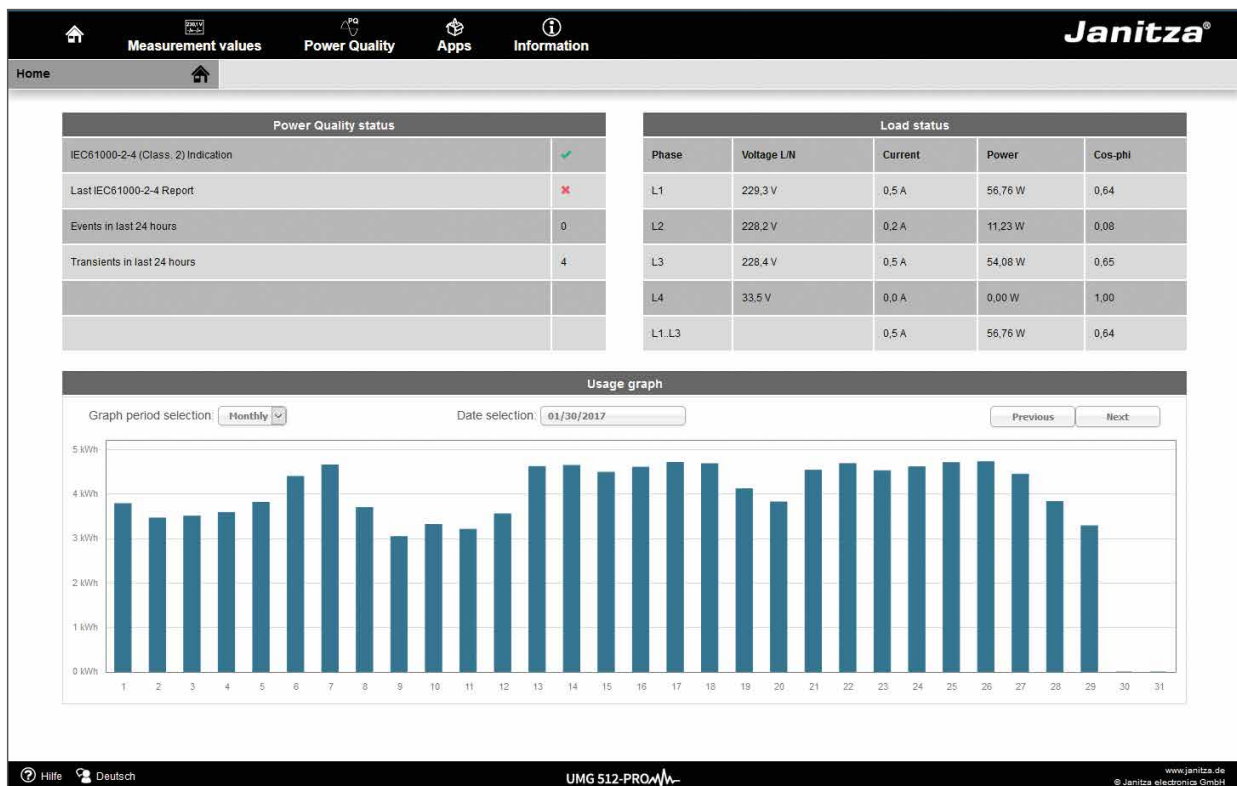

Fig. Device homepage overview

13.1 Measured values

The menu item "Measured values" allows you to call up simple and detailed views of measured values and visualize individual measured values. The following menu items are available here:

- Brief overview
- Detailed measured values
- Charts
- RCM - Residual current measurement
- Events

13.1.1 Brief overview

The brief overview shows the most important measured values for each phase, such as momentary voltage values, power values and current strength.

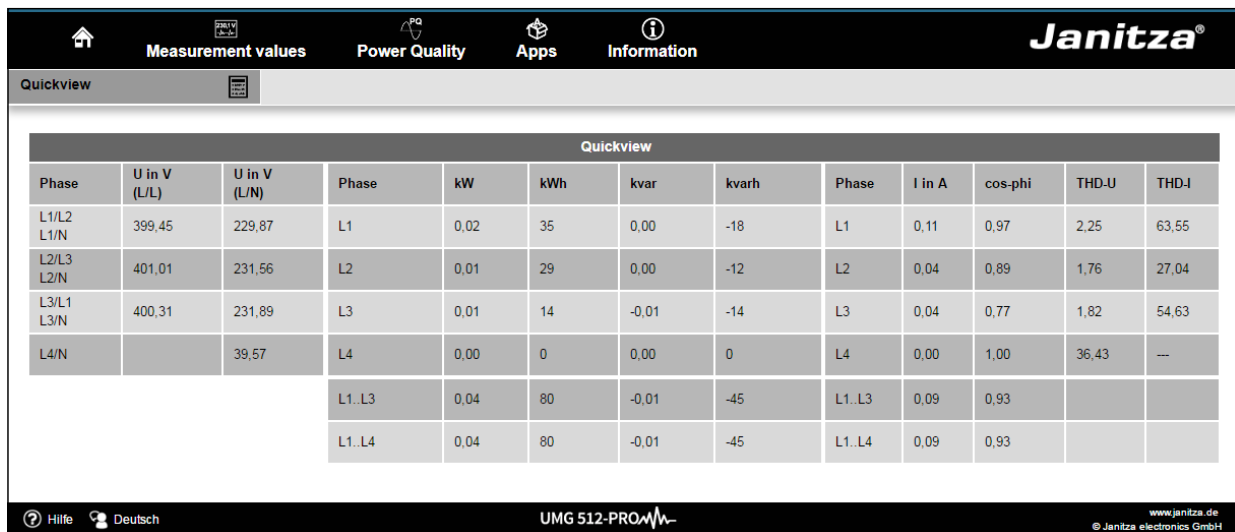

The screenshot shows the 'Quickview' section of the Janitza software interface. The table displays various electrical parameters for four phases (L1, L2, L3, L4) and their combinations. The parameters include voltage (U in V), power (kW, kWh, kvar, kvarh), current (I in A), power factor (cos-phi), and total harmonic distortion (THD-U, THD-I).

Quickview												
Phase	U in V (L/L)	U in V (L/N)	Phase	kW	kWh	kvar	kvarh	Phase	I in A	cos-phi	THD-U	THD-I
L1/L2 L1/N	399,45	229,87	L1	0,02	35	0,00	-18	L1	0,11	0,97	2,25	63,55
L2/L3 L2/N	401,01	231,56	L2	0,01	29	0,00	-12	L2	0,04	0,89	1,76	27,04
L3/L1 L3/N	400,31	231,89	L3	0,01	14	-0,01	-14	L3	0,04	0,77	1,82	54,63
L4/N		39,57	L4	0,00	0	0,00	0	L4	0,00	1,00	36,43	---
			L1..L3	0,04	80	-0,01	-45	L1..L3	0,09	0,93		
			L1..L4	0,04	80	-0,01	-45	L1..L4	0,09	0,93		

Fig. Brief overview of measured values

13.1.2 Detailed measured values

The overview provides access to extensive information on the following points:

- Voltage
- Current
- Power
- Harmonic oscillations
- Work
- Peripherals (digital inputs/outputs, temperature measurements)

The screenshot displays the 'Measurement values' section of the Janitza UMG 512-PRO software. The interface includes a navigation bar with 'Measurement values', 'Power Quality', 'Apps', and 'Information'. The main content area shows a detailed overview of measured values for Voltage, Current, Power, Harmonics, and Flicker. The 'Voltage' section is expanded, showing a table of effective voltage values for individual phases and line-to-line voltages, along with three-phase values and frequency data.

Voltage				
Voltage Effective				
	Actual value	Average value	Minimum value	Maximum value
L1	227.3 V	228.1 V	0.0 V	235.9 V
L2	227.8 V	228.6 V	0.0 V	236.6 V
L3	229.3 V	230.0 V	0.0 V	236.6 V
L4	1.2 V	1.2 V	0.0 V	1.7 V
L1-L2	384.1 V	385.6 V	0.0 V	409.0 V
L2-L3	395.5 V	397.0 V	0.0 V	409.7 V
L3-L1	395.6 V	396.8 V	0.0 V	408.7 V
Three-phase Values				
	Actual value	Average value	Minimum value	Maximum value
Unbalance Voltage	0.3 %	0.2 %	0.0 %	1.8 %
Frequency				
	Actual value	Average value	Minimum value	Maximum value
Frequency	50.0 Hz	50.0 Hz	49.9 Hz	50.1 Hz

Below the voltage table, there are expandable sections for 'Current', 'Power', 'Harmonics', and 'Flicker'. The interface also includes a 'Janitza' logo in the top right corner and a footer with 'UMG 512-PRO' and 'www.janitza.de'.

Fig. Detailed overview of measured values

13.1.3 Charts

You can access the measured value monitor via the "Charts" item. The measured value monitor is a configurable display of current and historical measured values with automatic scaling. To display a graph of the measured values, drag the desired values from the list on the left side of the screen into the field in the center of the screen.

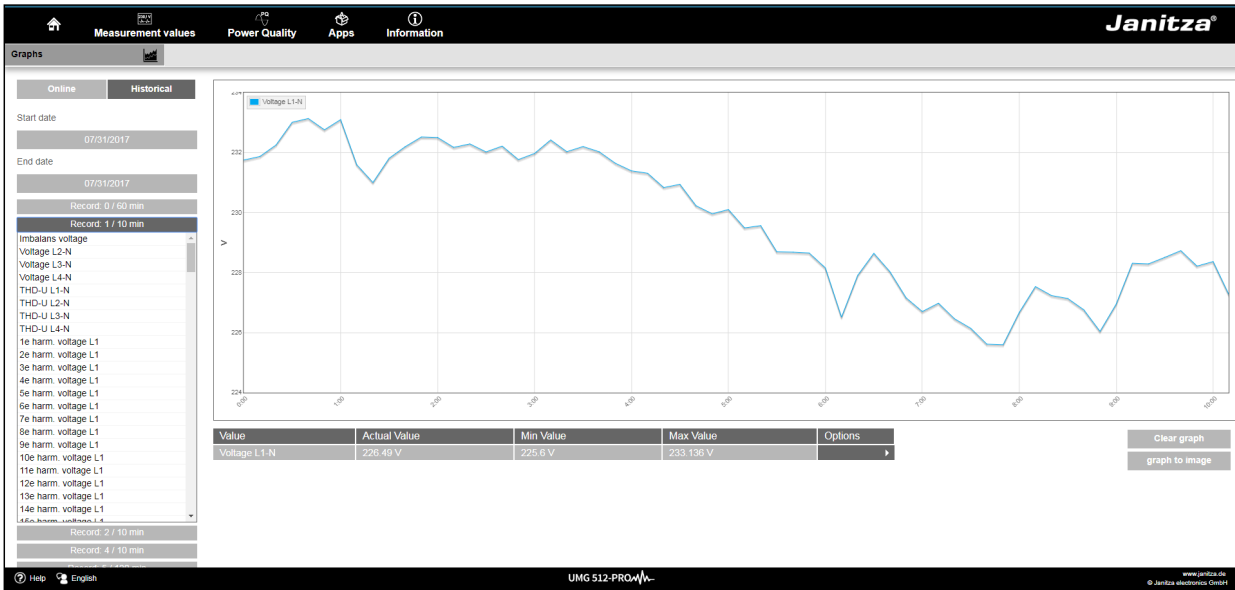

Fig. Device home page Event records

13.1.4 RCM - Residual current measurement

The item "RCM" shows you the instantaneous values and absolute limit values of the RCM channels. More detailed information on residual current measurement can be found in the section 7.8 on page 36.

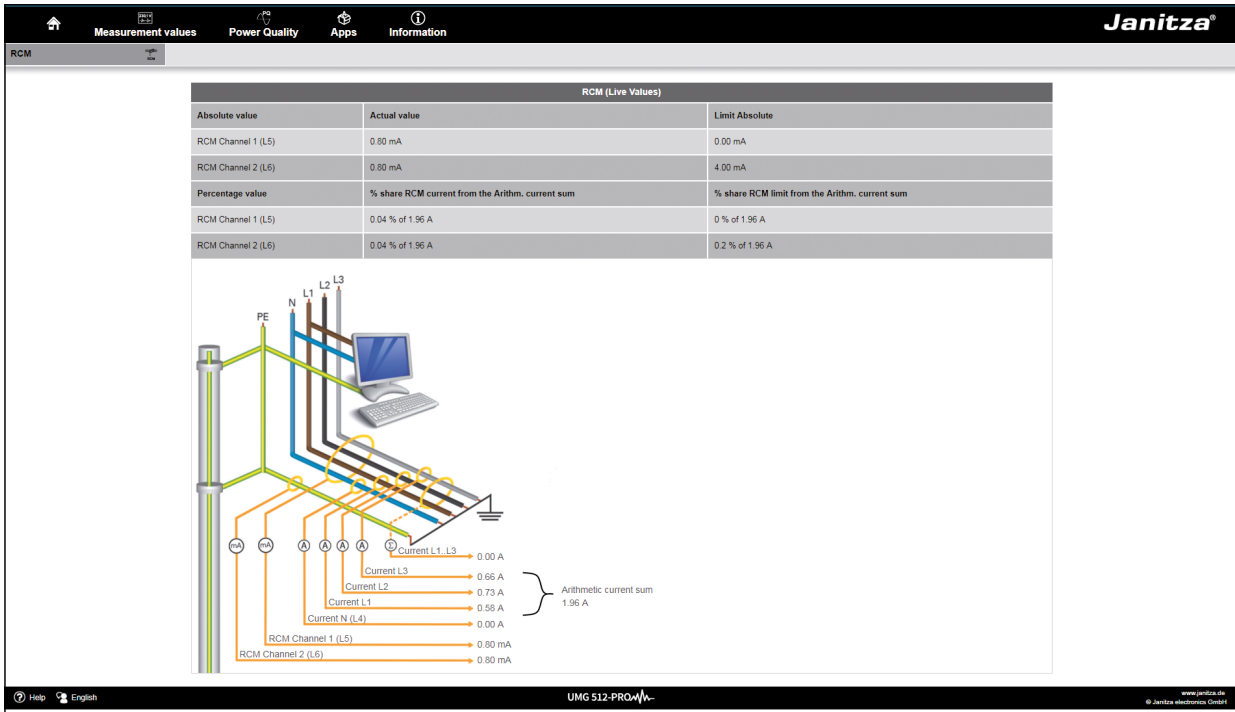

Fig. Device homepage RCM

13.1.5 Events

The "Events" item allows you to display a graphical representation of the recorded events, such as over-current or undervoltage. More information on event recording can be found at „11.3.3 Events“.

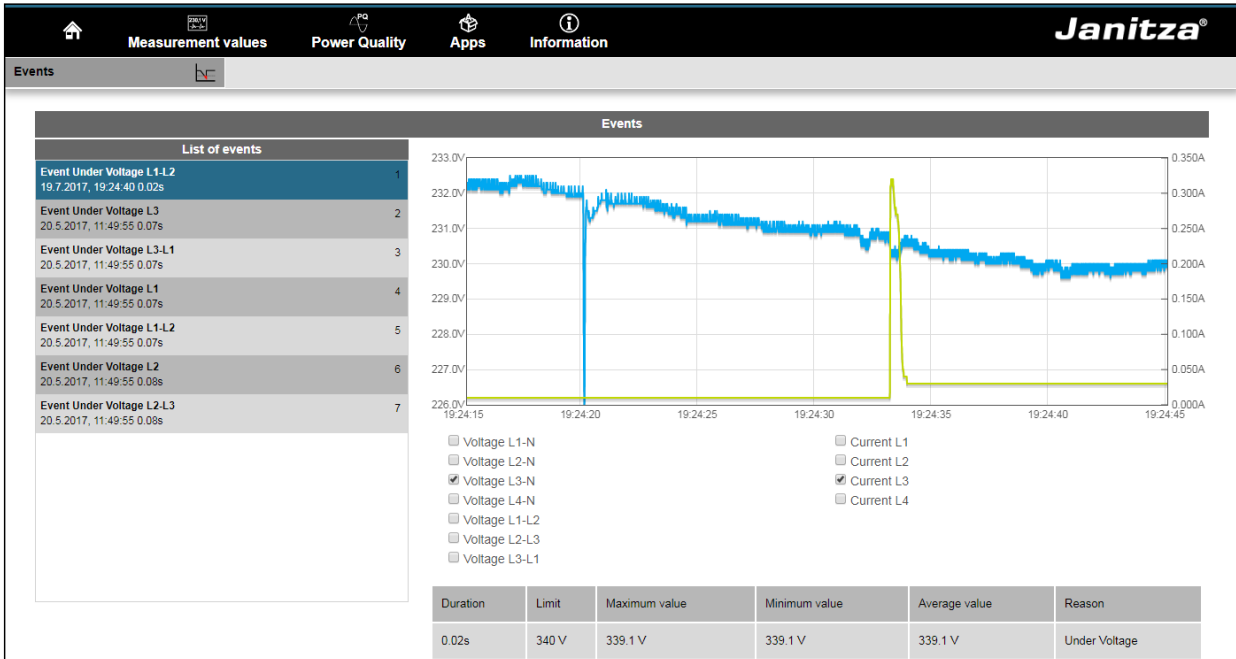

Fig. Event recording

13.2 Power quality

In the "Power Quality" (PQ) area, you have the option to retrieve the PQ status with a clear overview according to common standards. Here you have access to permanent monitoring of power quality according to:

- **EN 50160** PQ for energy supply networks
- **IEC 61000-2-4** PQ for customers' supply networks

The evaluation takes place via indicator (quick evaluation), as well as within the Watchdog app (temporal evaluation). The class of the IEC 61000-2-4 can be temporarily changed within the indicator settings. However, this has no lasting effect.

A change of the class is reset to class 2 ("compatibility level as in the public network") after leaving the page.

If you have installed further apps for the power quality, there are additional menu items in the "Power quality" menu:

1. For the app "IEC 61000-2-4 Watchdog":
 - **IEC 61000-2-4 settings**
 - **IEC 61000-2-4 Watchdog**

Changing the IEC 61000-2-4 class in the watchdog settings changes the class permanently in the watchdog, as well as in the indicator.

2. For the app "EN 50160 Watchdog":
 - **EN 50160 settings**
 - **EN 50160 Watchdog**

The display using the traffic light principle allows the events that do not comply with the respective quality agreements to be identified without in-depth knowledge.

IEC 61000-2-4 - Settings		
Nominal Voltage (V):	230	The voltage from which the limits are calculated (Default: 230V)
Nominal Frequency (Hz):	50	The frequency from which the limits are calculated (Default: 50Hz)
IEC 61000-2-4 Class:	Class 3 ('Industrial IPC')	According to which IEC class the measured values are assessed. (Default: Class 2)
Relevant voltages:	L / N	Voltage for IEC61000-2-4 report (Default: L/N)
Report period:	1 Day (24 hours)	1 report per day or 1 report per week (Default: 1 report per day)
Transients limit:	0	Maximum permissible transients before status report 'orange'. (Default: 0)
<input type="button" value="Save Settings"/>		

Fig. IEC61000-2-4 Watchdog settings for the report

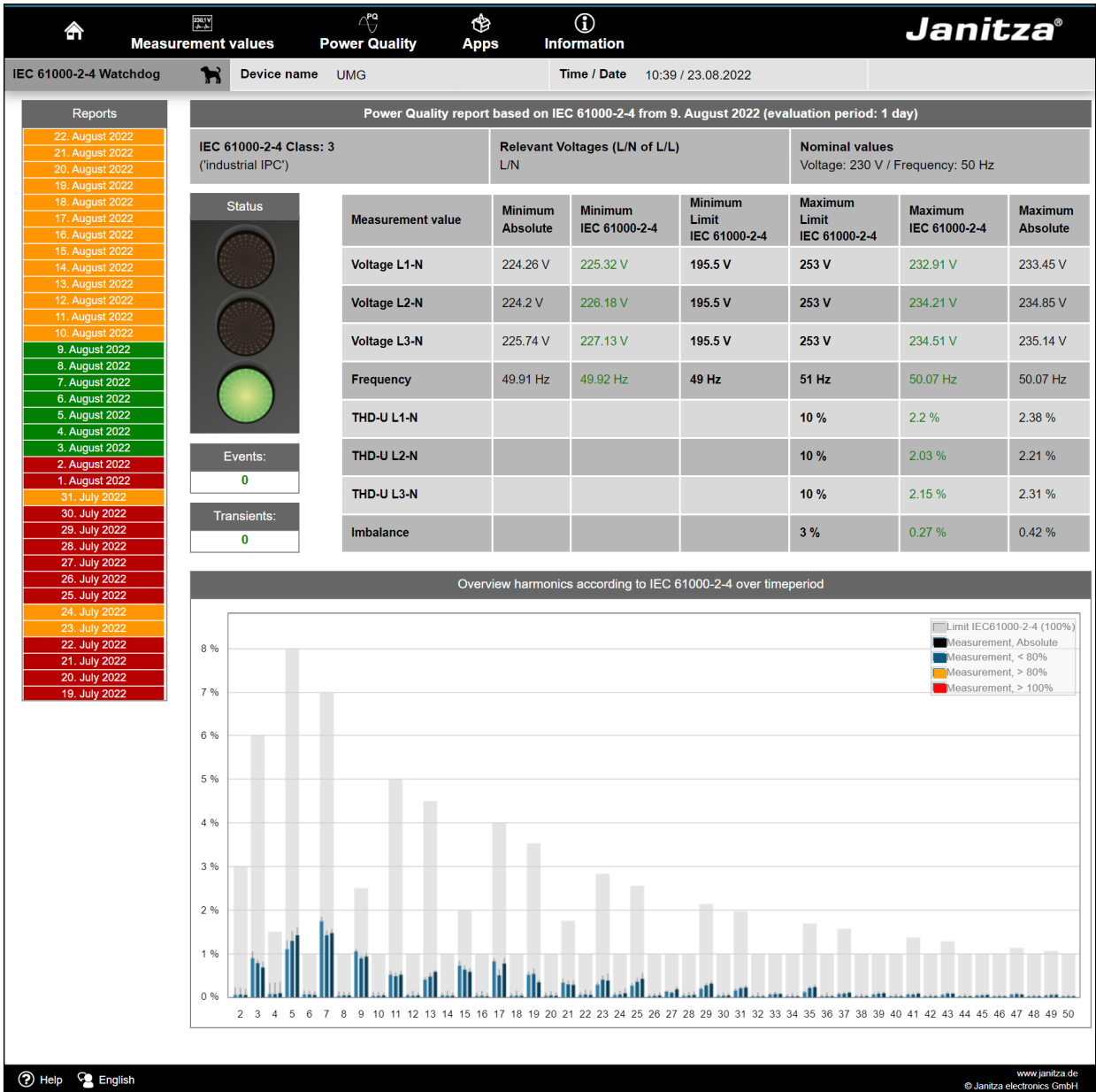

Fig. IEC 61000-2-4 Watchdog parameters with traffic light principle - report

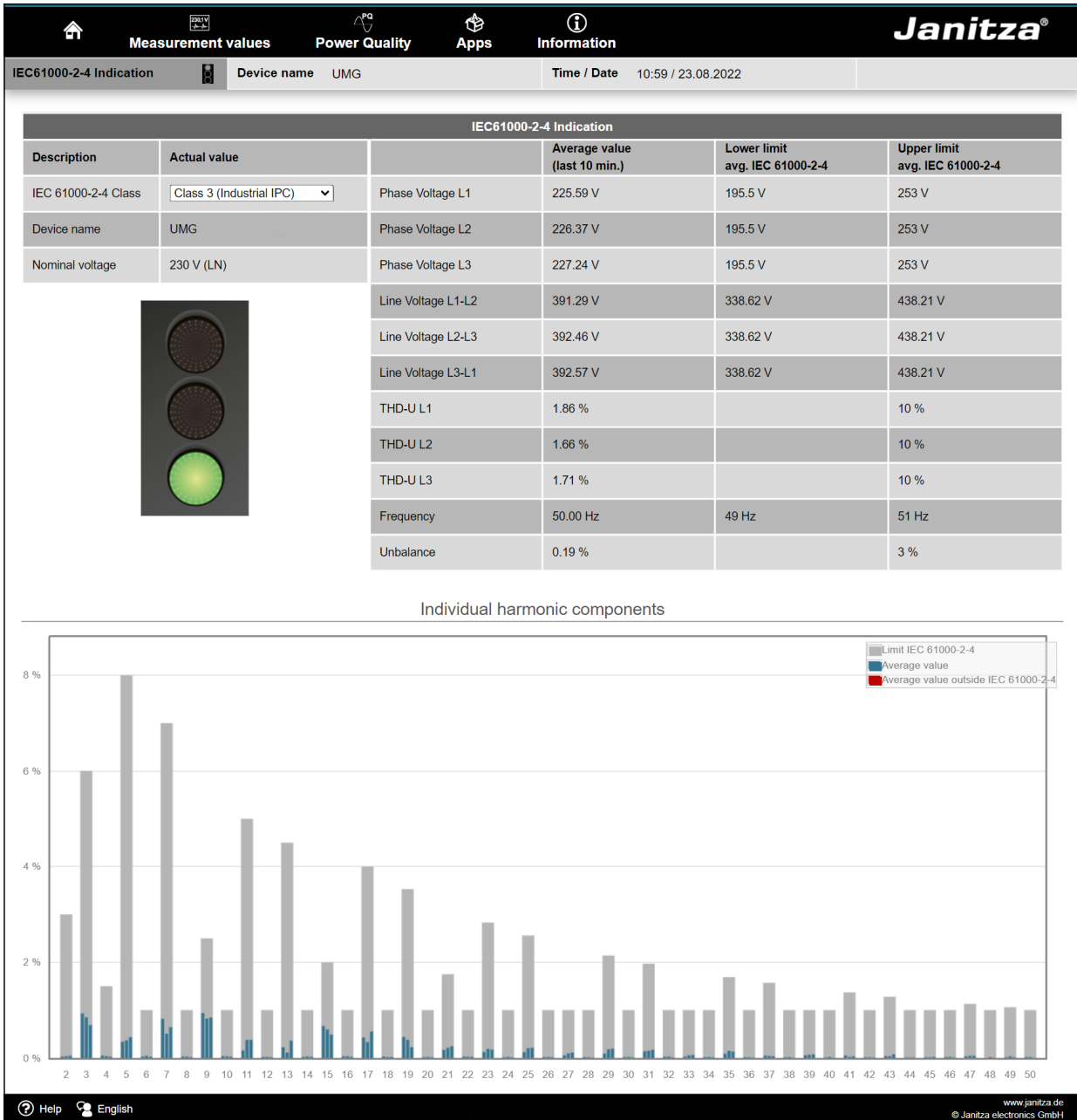

Fig. IEC61000-2-4 PQ indicator parameters with traffic light principle - snapshot

13.3 Apps

You have the option of enhancing the functionality of your device later on by installing additional apps.

13.3.1 Push Service

An example of an installable app is the Push Service. With the Push Service, measured values are sent directly from the device to a cloud or portal solution of your choice - such as the Janitza Energy Portal.

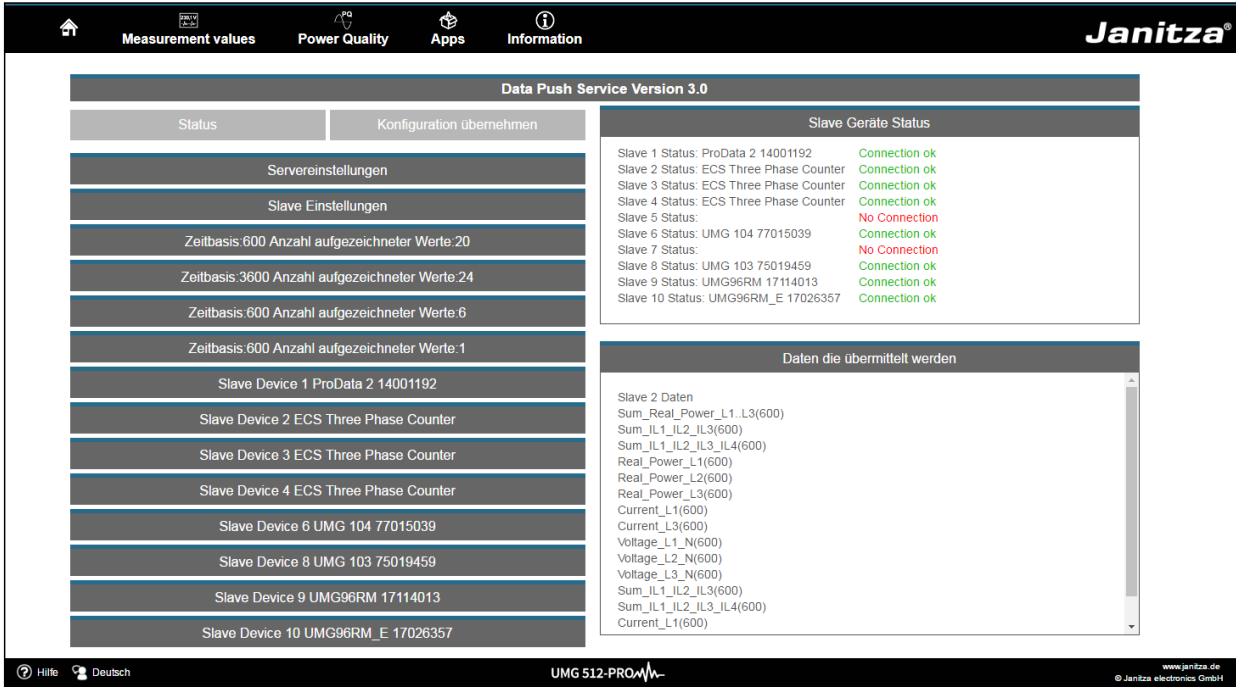

Fig. Push Service

13.4 Information

13.4.1 Device information

The "Device information" menu item shows all the information about the device as well as settings that you can change on it.

13.4.2 Display

The item Display shows the display of the device that corresponds to the actual display.

Pressing the operating buttons with the mouse allows you to remotely control the device here.

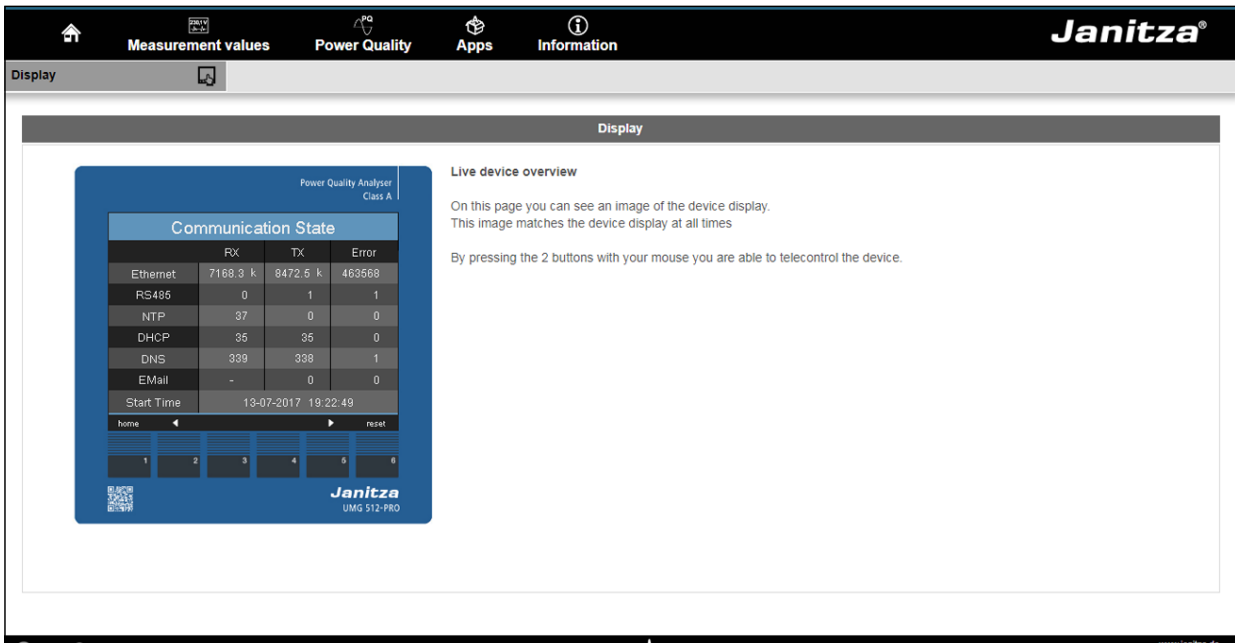

Fig. Operation of the UMG 512-PRO via the device homepage

13.4.3 Downloads

Click on "Downloads" to access the download area of the Janitza homepage. Here you are able to download catalogs and operating manuals.

14. Service and maintenance

Prior to outbound delivery, the device is subjected to various safety tests and is marked with a seal. If a device is opened, the safety tests must be repeated. A warranty is only assumed for unopened devices.

14.1 Repairs and calibration

Repairs and calibration can only be carried out by the manufacturer.

14.2 Front panel foil

The front panel foil can be cleaned with a soft cloth and standard household cleaning agents. Acids and acidic agents must not be used for cleaning.

14.3 Disposal

Please abide by national regulations! Dispose of individual parts, as applicable, depending on their composition and existing country-specific regulations, e.g. as:

- Electronic waste
- Plastics
- Metals

or engage a certified disposal company to handle scrapping.

14.4 Service

If questions arise that are not described in this manual, please contact the manufacturer directly. The following information is essential for us to be able to answer any questions you may have:

- Device designation (see rating plate)
- Serial number (see rating plate)
- Software release (see measuring display)
- Measured voltage and supply voltage
- An exact error description.

14.5 Device adjustment

The devices are adjusted by the manufacturer prior to outbound delivery. No readjustment is required when the environmental conditions are complied with.

14.6 Calibration intervals

A recalibration by the manufacturer or an accredited laboratory is recommended after about 5 years.

14.7 Firmware update

To perform a firmware update, connect the device to a computer via Ethernet and access it using the GridVis® software.

Open the firmware update wizard by clicking on "Update Device" in the "Extras" menu.

Select a corresponding update file and carry out the update.

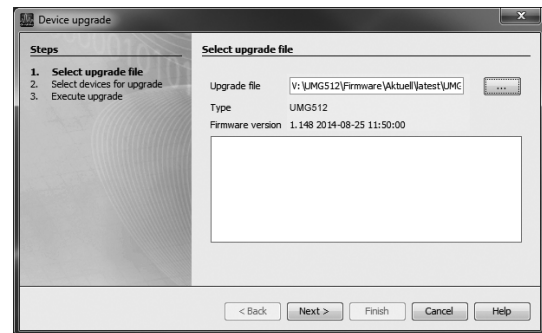

Fig. Firmware update wizard in the GridVis software

i INFORMATION

A firmware update is **not** possible using the RS-485 interface.

14.8 Battery

The internal clock is powered by the supply voltage. If the supply voltage fails, the clock is supplied by the battery. The clock provides date and time information for records, min and max values and events, for example.

The life expectancy of the battery is at least 5 years at a storage temperature of +45° C. The typical life expectancy of the battery is 8 to 10 years.

The battery (type CR2450 / 3 V) can be replaced by the user.

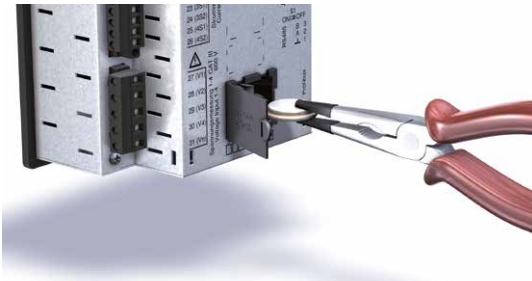

Fig. Battery replacement with needle-nose pliers

15. Technical data

General	
Net weight (with connectors)	approx. 1080 g (2.38 lbs)
Device dimensions	Approx. W = 144 mm (5.64 in), H = 144 mm (5.64 in), D = 75 mm (2.95 in)
Battery	Type LMO CR2450, 3 V (UL 1642 approved)
Clock - temperature range: -40 °C (-40 °F) to +85 °C 185 °F)	+5 ppm (equivalent to 3 minutes per year)
Impact resistance	IK07 according to IEC 62262

Transport and storage	
The following information applies to devices that are transported or stored in their original packaging.	
Free fall	1 m (39.37 in)
Temperature	-25 °C (-13 °F) to +70 °C (158 °F)

Environmental conditions during operation	
The device is intended for weather-protected, stationary use and must be connected to the ground wire connection! Protection class I according to IEC 60536 (VDE 0106, Part 1).	
Working temperature range	-10 °C (14 °F) to +55 °C (131 °F)
Relative humidity	5 to 95% at 25 °C (77 °F), no condensation
Operating elevation	0 .. 2000 m (6562 ft) above sea level
Pollution degree	2
Mounting orientation	Vertical
Ventilation	Forced ventilation is not required.
Protection against foreign matter and water · Front · Rear	IP40 according to EN60529 IP20 according to EN60529

15.1 Supply voltage

Supply voltage	
Installation overvoltage category	300 V CAT III
Fuse protection of the supply voltage (fuse)	6 A, type B (approved according to UL/IEC)
Option 230 V: · Nominal range · Operating range · Power consumption	95 V .. 240 V (50/60 Hz) / DC 80 V .. 300 V +-10% of nominal range max. 7 W / 14 VA
Option 24 V: · Nominal range · Operating range · Power consumption	48 V .. 110 V (50/60 Hz) / DC 24 .. 150 V +-10% of nominal range max. 9 W / 13 VA

Connecting capacity of the terminals (supply voltage)	
Connectible conductors. Only connect one conductor per terminal point!	
Single core, multi-core, fine-stranded	0.2 - 4.0 mm ² , AWG 28-12
Wire ferrules (non-insulated)	0.2 - 2.5 mm ² , AWG 26-14
Wire ferrules (insulated)	0.2 - 2.5 mm ² , AWG 26-14
Tightening torque	0.4 - 0.5 Nm (3.54 - 4.43 lbf in)
Strip length	7 mm (0.2756 in)

15.2 Voltage and current measurement

Current measurement	
Nominal current	5 A
Resolution	0.1 mA
Measuring range	0.005 .. 7 Arms
Overrange (overload)	from 8.5 Arms
Crest factor	1.41
Overvoltage category	Option 230 V: 300 V CAT III Option 24 V: 300 V CAT II
Rated surge voltage	4 kV
Power consumption	approx. 0.2 VA (Ri=5 mOhms)
Overload for 1 s	120 A (sinusoidal)
Sampling frequency	25.6 kHz / phase

Voltage measurement	
The voltage measurement inputs are suitable for measurement in the following power supply systems:	
Three-phase 4-conductor systems with rated voltages up to	417 V / 720 V (+10%) 347 V / 600 V (UL listed)
Three-phase 3-conductor systems with rated voltages up to	600 V (+10%)
The voltage measurement inputs are designed as follows from the point of view of safety and reliability:	
Overvoltage category	600 V CAT III
Rated surge voltage	6 kV
Protection of the voltage measurement	1-10 A
Measuring range L-N	0 ¹⁾ .. 600 Vrms
Measuring range L-L	0 ¹⁾ .. 1000 Vrms
Resolution	0.01 V
Crest factor	1.6 (referred to 600 Vrms)
Impedance	4 MOhms/phase
Power consumption	approx. 0.1 VA
Sampling frequency	25.6 kHz / phase
Transients	39 µs
U _{din} ²⁾ according to EN61000-4-30	100 .. 250 V
Flicker range (dU/U)	27.5%
Frequency of the fundamental oscillation · Resolution	15 Hz .. 440 Hz 0.001 Hz

1) The device can only determine measured values if a voltage L-N greater than 10 Vrms or a voltage L-L greater than 18 Vrms is present on at least one voltage measurement input.

2) U_{din} = Agreed input voltage according to DIN EN 61000-4-30

Measuring accuracy, phase angle	0.075 °
--	---------

Connecting capacity of the terminals (voltage measurement)	
Connectible conductors. Only connect one conductor per terminal point!	
Single core, multi-core, fine-stranded	0.2 - 4 mm ² , AWG 28-12
Wire ferrules (non-insulated)	0.2 - 2.5 mm ² , AWG 26-14
Wire ferrules (insulated)	0.2 - 2.5 mm ² , AWG 26-14
Tightening torque	0.4 - 0.5 Nm (3.54 - 4.43 lbf in)
Strip length	7 mm (0.2756 in)

Connecting capacity of the terminals (current measurement)	
Connectible conductors. Only connect one conductor per terminal point!	
Single core, multi-core, fine-stranded	0.2 - 4 mm ² , AWG 28-12
Wire ferrules (non-insulated)	0.2 - 4 mm ² , AWG 26-12
Wire ferrules (insulated)	0.2 - 2.5 mm ² , AWG 26-14
Tightening torque	0.4 - 0.5 Nm (3.54 - 4.43 lbf in)
Strip length	7 mm (0.2756 in)

15.3 Residual current measurement

Residual current measurement (RCM)	
Nominal current	30 mArms
Measuring range	0 .. 40 mArms
Operating current	100 µA
Resolution	1 µA
Crest factor	1.414 (relative to 40 mA)
Load	4 ohms
Overload for 1 s	5 A
Constant overloaded	1 A
Overload for 20 ms	50 A
Measurement of residual currents	according to IEC/TR 60755 (2008-01), Type A
Maximum external load	300 ohms (for cable break detection)

Terminal connection capacity (residual current measurement)	
Connectible conductors. Only connect one conductor per terminal point!	
Single core, multi-core, fine-stranded	0.2 - 1.5 mm ² , AWG 28-16
Wire ferrules (non-insulated)	0.2 - 1.5 mm ² , AWG 26-16
Wire ferrules (insulated)	0.2 - 1.5 mm ² , AWG 26-16
Tightening torque	0.2 - 0.25 Nm (1.77 - 2.21 lbf in)
Strip length	7 mm (0.2756 in)
Line length	Up to 30 m (32.81 yd) unshielded; greater than 30 m (32.81 yd) shielded

Potential isolation and electrical safety of the residual current measurement inputs	
<ul style="list-style-type: none"> · The RCM measurement inputs are double insulated relative to the current and voltage measurement inputs as well as to the supply voltage. · There is no insulation to the temperature measurement input. · There is only functional isolation relative to the Ethernet, Profibus, RS-485 and digital I/O interfaces. · The connected residual current transformers and the lines to be measured must each have at least an additional or a basic insulation in accordance with IEC61010-1:2010 for the mains voltage applied. 	

15.4 Temperature measurement input

Temperature measurement input 3-wire measurement	
Update time	1 second
Connectible sensors	PT100, PT1000, KTY83, KTY84
Total load (sensor and cable)	max. 4 kOhms
Line length	Up to 30 m (32.81 yd) unshielded; greater than 30 m (32.81 yd) shielded

Sensor type	Temperature range	Resistance range	Measurement uncertainty
KTY83	-55 °C (-67 °F) ... +175 °C (347 °F)	500 ohms ... 2.6 kOhms	±1.5% rng
KTY84	-40 °C (-40 °F) ... +300 °C (572 °F)	350 ohms ... 2.6 kOhms	±1.5% rng
PT100	-99 °C (-146 °F) ... +500 °C (932 °F)	60 ohms ... 280 ohms	±1.5% rng
PT1000	-99 °C (-146 °F) ... +500 °C (932 °F)	600 ohms ... 2.8 kOhms	±1.5% rng

Terminal connection capacity (temperature measurement input) Connectible conductors. Only connect one conductor per terminal point!	
Single core, multi-core, fine-stranded	0.2 - 1.5 mm ² , AWG 28-16
Wire ferrules (non-insulated)	0.2 - 1.5 mm ² , AWG 26-16
Wire ferrules (insulated)	0.2 - 1.5 mm ² , AWG 26-16
Tightening torque	0.2 - 0.25 Nm (1.77 - 2.21 lbf in)
Strip length	7 mm (0.2756 in)

Potential isolation and electrical safety of the temperature measurement inputs
<ul style="list-style-type: none"> · The temperature measurement input is double insulated relative to the current and voltage measurement inputs as well as to the supply voltage. · There is no insulation relative to the RCM measurement input. · There is only functional isolation relative to the Ethernet, Profibus, RS-485 and digital I/O interfaces. · The external temperature sensor must be double insulated relative to system components with dangerous contact voltage (according to IEC61010-1:2010).

15.5 Digital inputs and outputs

Digital inputs	
2 digital inputs with a common ground	
Maximum counter frequency	20 Hz
Response time (Jasic program)	200 ms
Input signal applied	18 V .. 28 V DC (typically 4 mA) (SELV or PELV supply)
Input signal not applied	0 .. 5 V DC, current less than 0.5 mA
Line length	Up to 30 m (32.81 yd) unshielded; greater than 30 m (32.81 yd) shielded

Digital outputs	
2 digital outputs with a common ground; optocoupler, not short-circuit proof	
Operating voltage	20 V - 30 V DC (SELV or PELV supply)
Switching voltage	Max. 60 V DC
Switching current	max. 50 mA _{eff} AC/DC
Response time (Jasic program)	200 ms
Switching frequency	max. 20 Hz
Line length	Up to 30 m (32.81 yd) unshielded; greater than 30 m (32.81 yd) shielded

Terminal connection capacity (digital inputs and outputs)	
Connectible conductors. Only connect one conductor per terminal point!	
Single core, multi-core, fine-stranded	0.2 - 1.5 mm ² , AWG 28-16
Wire ferrules (non-insulated)	0.2 - 1.5 mm ² , AWG 26-16
Wire ferrules (insulated)	0.2 - 1.5 mm ² , AWG 26-16
Tightening torque	0.2 - 0.25 Nm (1.77 - 2.21 lbf in)
Strip length	7 mm (0.2756 in)

Potential isolation and electrical safety of the digital inputs and outputs	
<ul style="list-style-type: none"> · The digital inputs and outputs are double insulated relative to the current and voltage measurement inputs as well as to the supply voltage. · There is only functional isolation relative to each other and to the Ethernet, Profibus, RS-485 and digital I/O interfaces. · The auxiliary voltage to be connected externally must be realized as SELV or PELV. 	

15.6 Interfaces

RS-485 interface	
3-wire connection with GND, A, B	
Protocol	Modbus RTU/slave, Modbus RTU/master, Modbus RTU /gateway
Transmission rate	9.6 kbps, 19.2 kbps, 38.4 kbps, 57.6 kbps, 115.2 kbps, 921.6 kbps
Termination resistor	Can be activated via microswitch

Terminal connection capacity (serial interface - RS-485)	
Connectible conductors. Only connect one conductor per terminal point!	
Single core, multi-core, fine-stranded	0.2 - 1.5 mm ² , AWG 28-16
Wire ferrules (non-insulated)	0.2 - 1.5 mm ² , AWG 26-16
Wire ferrules (insulated)	0.2 - 1.5 mm ² , AWG 26-16
Tightening torque	0.2 - 0.25 Nm (1.77 - 2.21 lbf in)
Strip length	7 mm (0.2756 in)

Profibus interface	
Connection	SUB D 9-pin
Protocol	Profibus DP/V0 according to EN 50170
Transmission rate	9.6 kBaud to 12 MBaud

Ethernet interface	
Connection	RJ45
Function	Modbus gateway, embedded web server (HTTP)
Protocols	CP/IP, EMAIL (SMTP), DHCP client (BootP), Modbus/TCP, Modbus RTU over Ethernet, FTP, ICMP (ping), NTP, TFTP, BACnet (option), SNMP,

Potential isolation and electrical safety of the interfaces	
<ul style="list-style-type: none"> · The RS-485, Profibus and Ethernet interfaces are double insulated relative to the current and voltage measurement inputs and the supply voltage. · There is only functional isolation relative to each other and to the RCM and temperature measurement inputs and to the digital I/O interfaces. · The interfaces of the devices connected here must have double or reinforced insulation against mains voltages (according to IEC 61010-1: 2010). 	

15.7 Performance characteristics of functions

15.7.1 Measurements at 50/60 Hz

The measurements are made via current transformers $\dots/5$ A.

Function	Symbol	Accuracy class	Measuring range	Display range
Total active power	P	0.2 ⁵⁾ (IEC61557-12)	0 .. 15.3 kW	0 W .. 9999 GW *
Total reactive power	QA ⁶⁾ , Qv ⁶⁾	1 (IEC61557-12)	0 .. 15.3 kvar	0 varh .. 9999 Gvar *
Total apparent power	SA, Sv ⁶⁾	0.2 ⁵⁾ (IEC61557-12)	0 .. 15.3 kVA	0 VA .. 9999 GVA *
Total active energy	Ea	0.2 ⁵⁾ (IEC61557-12) 0.2S ⁵⁾ (IEC62053-22) 0.2 (ANSI C12.20)	0 .. 15.3 kWh	0 Wh .. 9999 GWh *
Total reactive energy	ErA ⁶⁾ , ErV ⁶⁾	1 (IEC61557-12)	0 .. 15.3 kvarh	0 varh .. 9999 Gvarh *
Total apparent energy	EapA, EapV ⁶⁾	0.2 ⁵⁾ (IEC61557-12)	0 .. 15.3 kVAh	0 VAh .. 9999 GVAh *
Frequency	f	0.02 (IEC61557-12)	40 .. 70 Hz	40 Hz .. 70 Hz
Phase current	I	0.1 (IEC61557-12)	0.005 .. 7 Arms	0 A .. 9999 kA
Neutral conductor current measured	IN	0.1 (IEC61557-12)	0.005 .. 7 Arms	0 A .. 9999 kA
Residual currents I5, I6	IDIFF	1 (IEC61557-12)	0 .. 40 mArms	0 A .. 9999 kA
Neutral conductor current calculated	INc	0.5 (IEC61557-12)	0.005 .. 21 A	0 A .. 9999 kA
Voltage	U L-N	0.1 (IEC61557-12)	10 .. 600 Vrms	0 V .. 9999 kV
Voltage	U L-L	0.1 (IEC61557-12)	18 .. 1000 Vrms	0 V .. 9999 kV
Power factor	PFA, PFV	0.5 (IEC61557-12)	0.00 .. 1.00	0 .. 1
Short-term flicker, long-term flicker	Pst, Plt	Cl. A (IEC61000-4-15)	0.4 pst to 10.0 pst	0 .. 10
Voltage dips	Udip	0.2 (IEC61557-12)	10 .. 600 Vrms	0 V .. 9999 kV
Voltage swells	Uswl	0.2 (IEC61557-12)	10 .. 600 Vrms	0 V .. 9999 kV
Transient overvoltages	Utr	0.2 (IEC61557-12)	10 .. 600 Vrms	0 V .. 9999 kV
Voltage interruptions	Uint	Duration +- 1 cycle	-	-
Voltage unbalance ¹⁾	Unba	0.2 (IEC61557-12)	10 .. 600 Vrms	0 V .. 9999 kV
Voltage unbalance ²⁾	Unb	0.2 (IEC61557-12)	10 .. 600 Vrms	0 V .. 9999 kV
Voltage harmonics	Uh	Cl. 1 (IEC61000-4-7)	Up to 3 kHz	0 V .. 9999 kV
THD of the voltage ³⁾⁷⁾	THDu	1.0 (IEC61557-12)	Up to 3 kHz	0% .. 999%
THD of the voltage ⁴⁾⁷⁾	THD-Ru	1.0 (IEC61557-12)	Up to 3 kHz	0% .. 999%
Current harmonics ⁷⁾	Ih	Cl. 1 (IEC61000-4-7)	Up to 3 kHz	0 A .. 9999 kA
THD of the current ³⁾⁷⁾	THDi	1.0 (IEC61557-12)	Up to 3 kHz	0% .. 999%
THD of the current ⁴⁾⁷⁾	THD-Ri	1.0 (IEC61557-12)	Up to 3 kHz	0% .. 999%
Mains signal voltage (interharmonics voltage)	MSV	IEC 61000-4-7 Class 1	10% - 200% of IEC 61000-2-4 Class 3	0 V .. 9999 kV

15.7.2 Measurements in the range 15..45 / 65..440 Hz

Function	Symbol	Accuracy class	Measuring range	Display range
Total active power	P	2 (IEC61557-12)	0 .. 15.3 kW	0 W .. 9999 GW *
Total reactive power	QA ⁶⁾ , Qv ⁶⁾	2 (IEC61557-12)	0 .. 15.3 kvar	0 varh .. 9999 Gvarh *
Total apparent power	SA, Sv ⁶⁾	1 (IEC61557-12)	0 .. 15.3 kVA	0 VA .. 9999 GVA *
Total active energy	Ea	2 (IEC61557-12)	0 .. 15.3 kWh	0 Wh .. 9999 GWh *
Total reactive energy	ErA ⁶⁾ , ErV ⁶⁾	2 (IEC61557-12)	0 .. 15.3 kvarh	0 varh .. 9999 Gvarh *
Total apparent energy	EapA, EapV ⁶⁾	1 (IEC61557-12)	0 .. 15.3 kVAh	0 VAh .. 9999 GVAh *
Frequency	f	0.02 (IEC61557-12)	15 .. 440 Hz	15 Hz .. 440 Hz
Phase current	I	0.5 (IEC61557-12)	0.005 .. 7 Arms	0 A .. 9999 kA
Neutral conductor current measured	IN	0.5 (IEC61557-12)	0.005 .. 7 Arms	0 A .. 9999 kA
Residual currents I5, I6	IDIFF	1 (IEC61557-12)	0 .. 40 mArms	0 A .. 9999 kA
Neutral conductor current calculated	INc	1.5 (IEC61557-12)	0.005 .. 21 A	0 A .. 9999 kA
Voltage	U L-N	0.5 (IEC61557-12)	10 .. 600 Vrms	0 V .. 9999 kV
Voltage	U L-L	0.5 (IEC61557-12)	18 .. 1000 Vrms	0 V .. 9999 kV
Power factor	PFA, PFV	2 (IEC61557-12)	0.00 .. 1.00	0 .. 1
Short-term flicker, long-term flicker	Pst, Plt	-	-	-
Voltage dips	Udip	0.5 (IEC61557-12)	10 .. 600 Vrms	0 V .. 9999 kV
Voltage swells	Uswl	0.5 (IEC61557-12)	10 .. 600 Vrms	0 V .. 9999 kV
Transient overvoltages	Utr	0.5 (IEC61557-12)	10 .. 600 Vrms	0 V .. 9999 kV
Voltage interruptions	Uint	Duration +- 1 cycle	-	-
Voltage unbalance ¹⁾	Unba	0.5 (IEC61557-12)	10 .. 600 Vrms	0 V .. 9999 kV
Voltage unbalance ²⁾	Unb	0.5 (IEC61557-12)	10 .. 600 Vrms	0 V .. 9999 kV
Voltage harmonics ³⁾	Uh	Cl. 2 (IEC61000-4-7)	Up to 3 kHz	0 V .. 9999 kV
THD of the voltage ⁴⁾	THDu	2.0 (IEC61557-12)	Up to 3 kHz	0% .. 999%

1) Referenced to amplitude.

2) Referenced to the phase and amplitude.

3) Referenced to the fundamental oscillation.

4) Referenced to the effective value.

5) Accuracy class 0.2/0.2S with ..5 A transformer.

Accuracy class 0.5/0.5S with ..1A transformer.

6) Calculation from the fundamental oscillation.

7) Measuring range: up to 50. Harmonics, but maximum 3 kHz

* When the maximum total work values are reached, the display returns to 0 W.

INFORMATION

Note on saving measured values and configuration data:

Since the following measured values are stored in a non-volatile memory every 5 minutes, an **operating voltage failure** can cause an interruption of the recording of max. 5 minutes:

- **Comparator timer**
- **S0 meter readings**
- **Min. / max. / average values (without date and time)**
- **Energy values**

Configuration data are saved immediately.

A detailed Modbus address and parameter list can be found at www.janitza.com.

15.8 Specifications according to IEC 61000-4-30

Feature	Uncertainty	Measuring range
5.1 Frequency	± 10 mHz	42.5 Hz - 57.5 Hz 51 Hz - 69 Hz
5.2 Supply voltage level	$\pm 0.1\%$ of U_{din}	10% - 150% of U_{din}
5.3 Flicker	$\pm 5\%$ of the measured value	0.2 - 10 Pst
5.4 Dips and overvoltages	Amplitude: $\pm 0.2\%$ of U_{din} Duration: ± 1 period	N/A
5.5 Voltage interruptions	Duration: ± 1 period	N/A
5.7 Unbalance	$\pm 0.15\%$	0.5% - 5% u_2 0.5% - 5% u_0
5.8 Harmonics current	IEC 61000-4-7 Class 1	10% - 200% of Class 3 of IEC 61000-2-4
5.9 Interharmonics	IEC 61000-4-7 Class 1	10% - 200% of Class 3 of IEC 61000-2-4
5.10 Mains signal voltage	In the range of 3%-15% of U_{din} , $\pm 5\%$ of U_{din} . In the range of 1%-3% of U_{din} , $\pm 0.15\%$ of U_{din} . There are no uncertainty requirements for values $< 1\%$ of U_{din} .	0% - 15% of U_{din}
5.12 Under/over deviation	$\pm 0.1\%$ of U_{din}	10% - 150% of U_{din}

INFORMATION

To ensure that two measurement devices achieve the same measurement results in a 10-min aggregation time interval, we recommend synchronizing the time measurement in the device using an external time signal.

INFORMATION

NOTE!

The device meets the requirements of IEC 61000-4-30 Class A for:

- Aggregations
- Uncertainty of the clock time
- Marking concept
- Transient influencing variables

15.9 Dimensional drawings

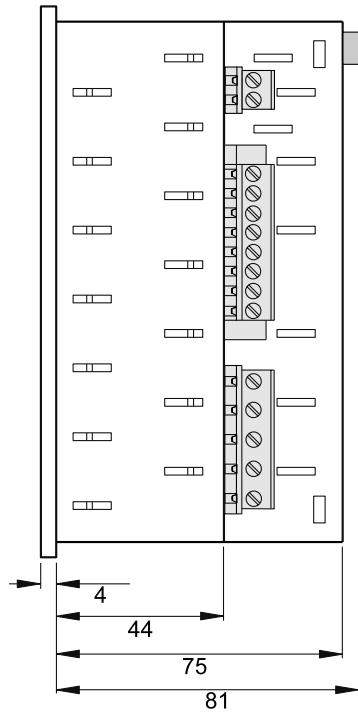

Fig. View from the side

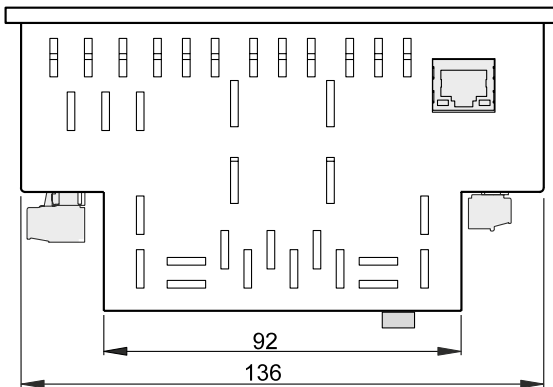

Fig. View from below

16. Procedure in the event of a malfunction

Failure mode	Cause	Remedy
No display	External fuse for the supply voltage has tripped.	Replace fuse.
No current display.	No measured voltage connected.	Connect measured voltage.
	No measured current connected.	Connect measured current.
Displayed current is too great or too small.	Current measurement on the wrong phase.	Check connection and correct if necessary.
	Current transformer factor incorrectly programmed.	Read and program the current transformer ratio on the current transformer.
	The peak current value at the measuring input was exceeded by current harmonics.	Install current transformers with a higher current transformer ratio.
	The current at the measuring input is too low.	Install current transformers with a lower current transformer ratio.
Displayed voltage is too low or too high.	Measurement on the wrong phase.	Check connection and correct if necessary.
	Voltage transformer programmed incorrectly.	Read the voltage transformer ratio on the voltage transformer and program.
Displayed voltage is too low.	Overrange.	Use a voltage transformer.
	The voltage peak value at the measuring input was exceeded due to harmonics current.	Attention! Be absolutely certain that the measurement inputs are not overloaded.
Phase shift, ind./cap.	Current circuit is assigned to the wrong voltage circuit.	Check connection and correct if necessary.
Active power consumption /delivered is interchanged.	At least one current transformer connection is reversed.	Check connection and correct if necessary.
	A current circuit is assigned to the wrong voltage circuit.	Check connection and correct if necessary.

Failure mode	Cause	Remedy
Active power too small or too great.	The programmed current transformer ratio is incorrect.	Read and program the current transformer ratio on the current transformer
	The current circuit is assigned to the wrong voltage circuit.	Check connection and correct if necessary.
	The programmed voltage transformer ratio is incorrect.	Read the voltage transformer ratio on the voltage transformer and program.
One output is not responding.	The output has been programmed incorrectly.	Check programming and correct if necessary.
	The output has been connected incorrectly.	Check connection and correct if necessary.
Display of measuring range exceeded (overload)	Voltage or current measurement input outside the measuring range (Also see section „12.8 Overrange“)	Check connection and correct if necessary.
		Use suitable voltage or current transformers.
		Read and program the voltage or current transformer ratio on the transformer.
No connection to the device.	RS-485	
	Incorrect device address.	Correct the device address.
	Different bus speeds (baud rate).	Correct the speed (baud rate).
	Incorrect protocol.	Correct the protocol.
	No termination.	Terminate bus with termination resistor.
	Ethernet	
	Incorrect device IP address.	Correct the device IP address.
	Incorrect addressing mode	Correct the mode for assigning the IP address
Despite the above measures, the device does not function.	Device defective.	Send the device to the manufacturer for inspection with an exact description of the fault.

17. Menu navigation overview

17.1 Configuration menu overview

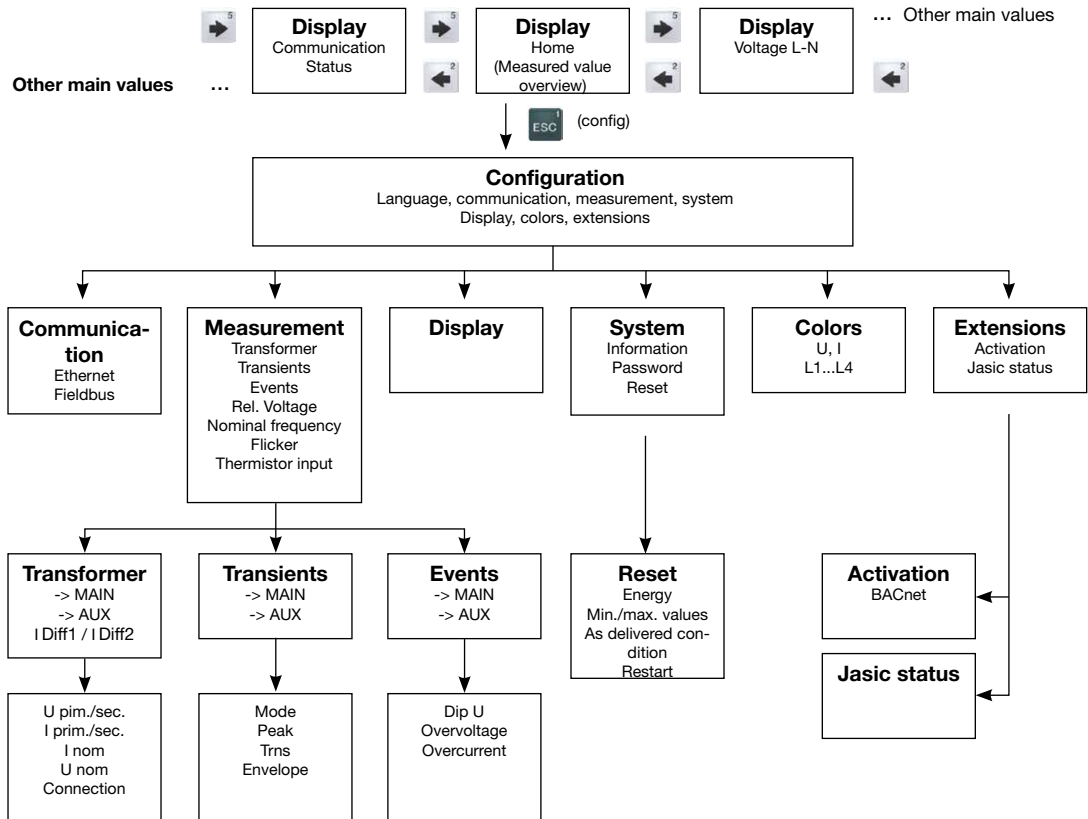

Fig. Schematic representation of the menu navigation for the configuration menu

17.2 Overview of measuring displays

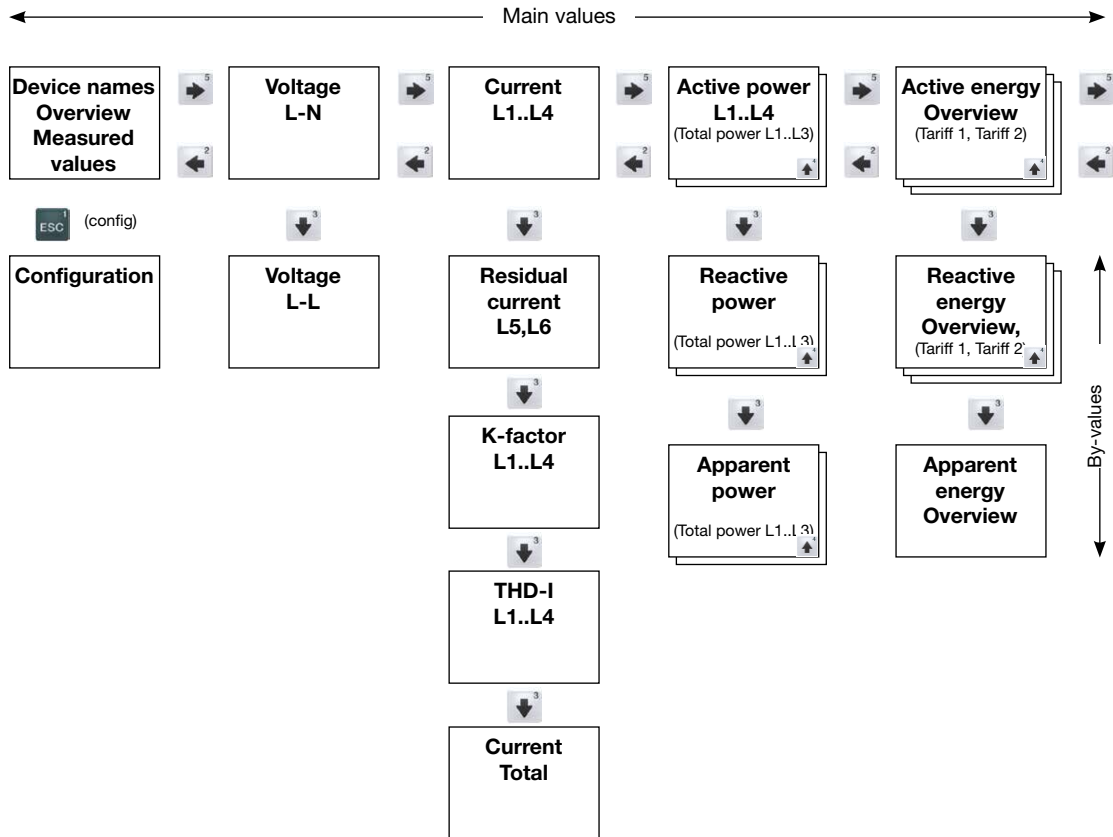

Fig. Schematic representation of the menu navigation for the measuring displays, part 1

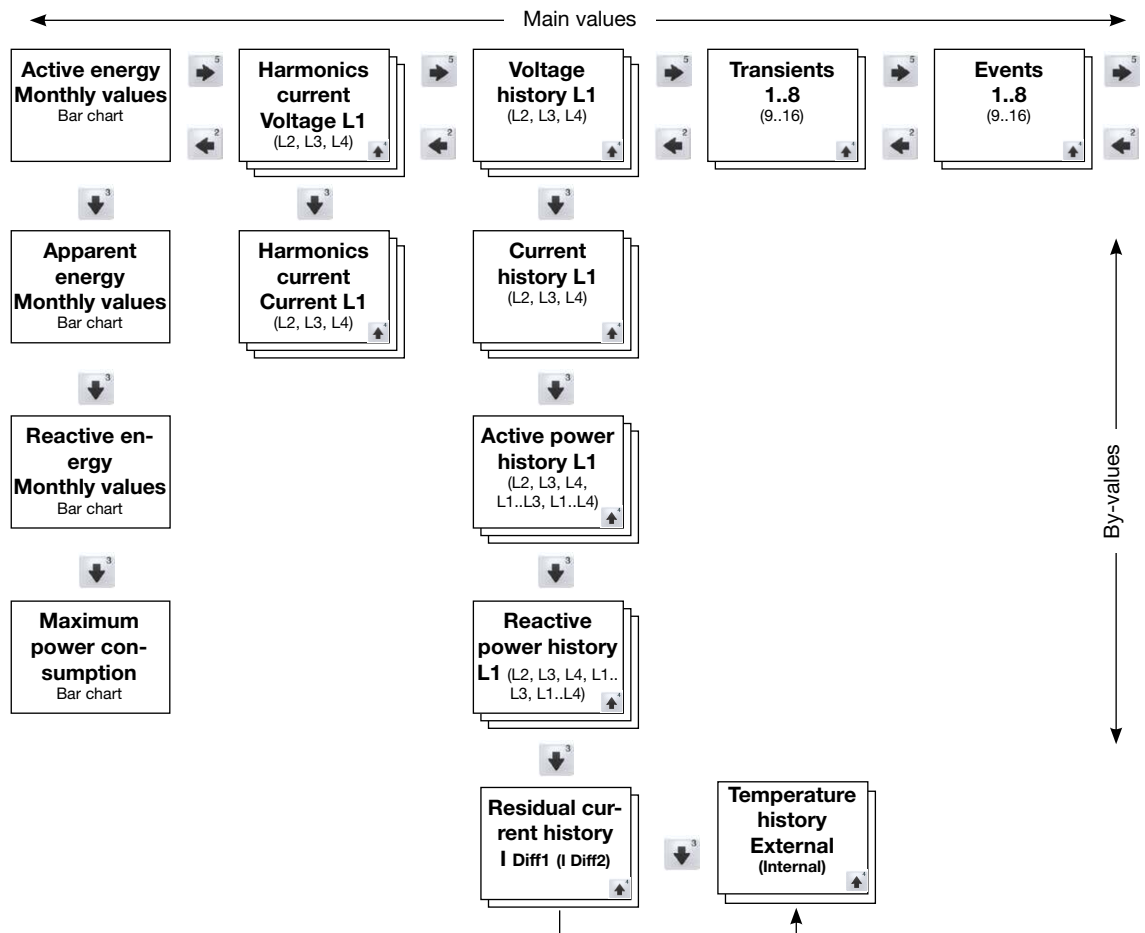

Fig. Schematic representation of the menu navigation for the measuring displays, part 2

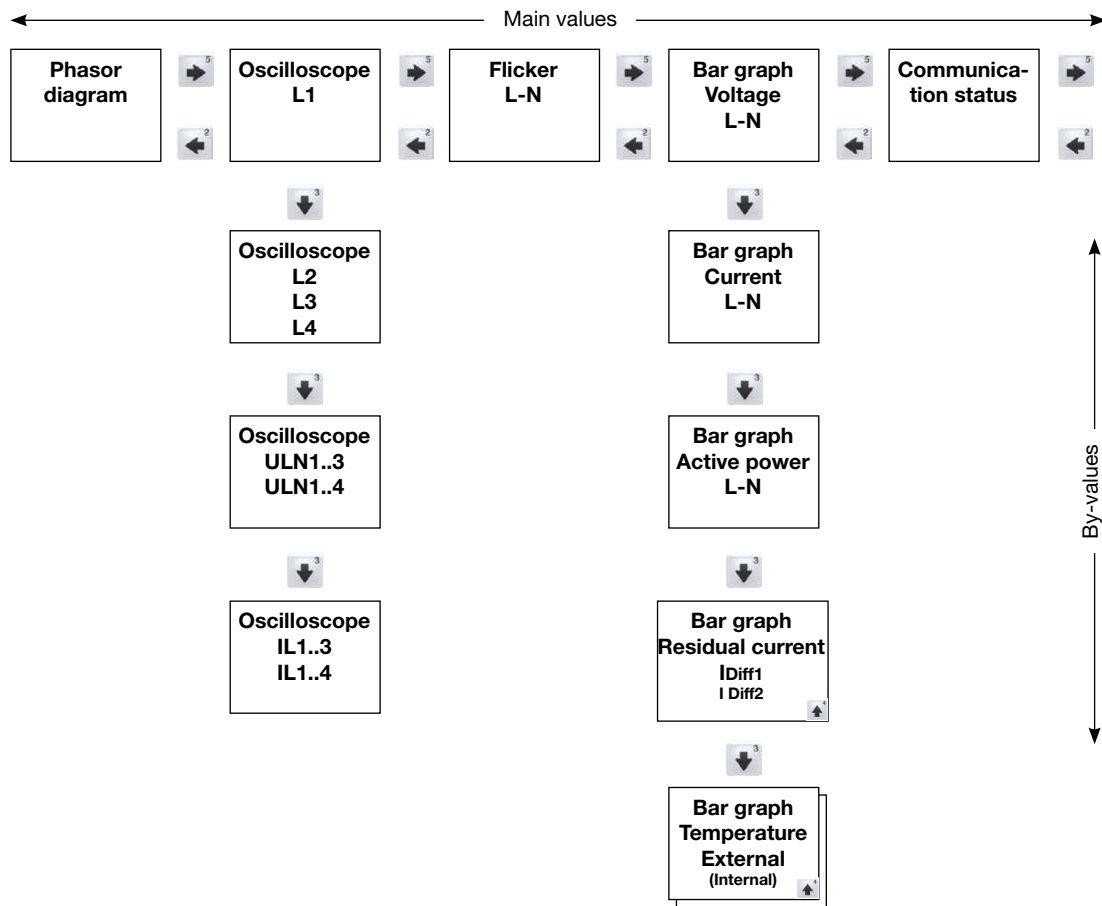

Fig. Schematic representation of the menu navigation for the measuring displays, part 3

18. Connection example

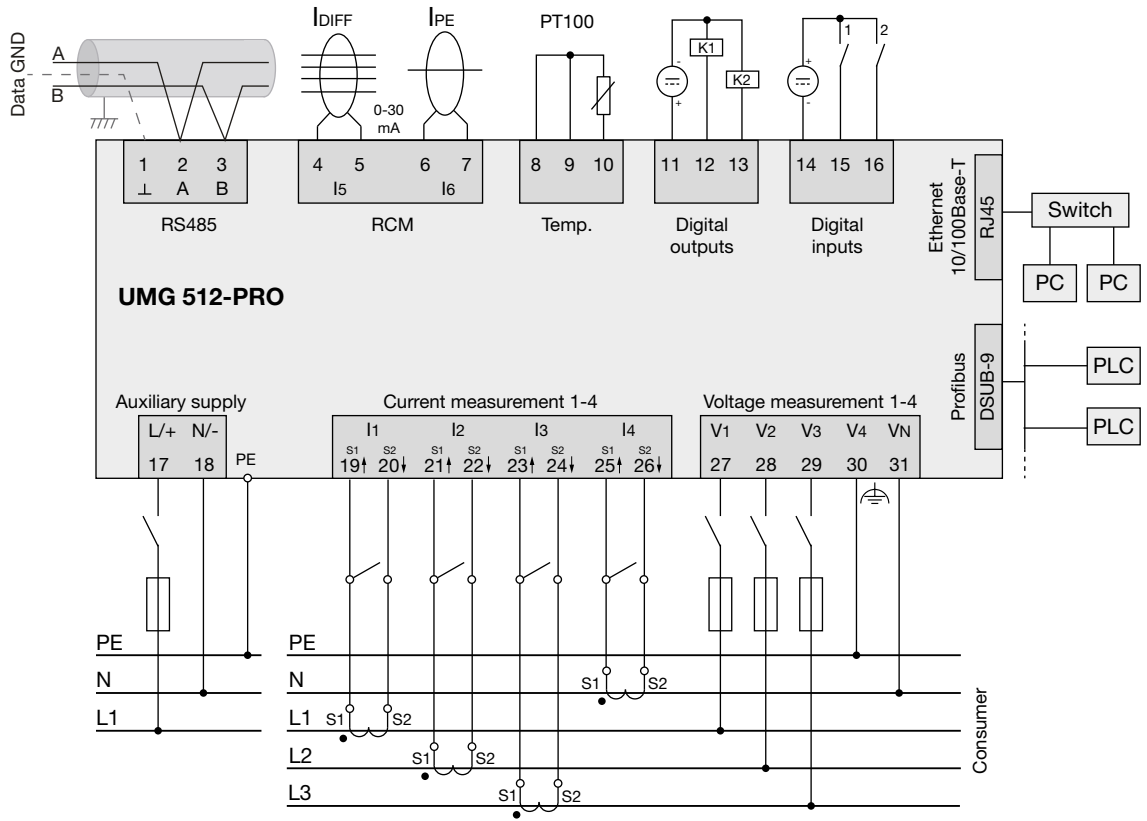

Fig. Schematic drawing, connection example for the UMG 512-PRO

Janitza

Janitza electronics GmbH
Vor dem Polstück 6 | 35633 Lahnau
Germany

Tel. +49 6441 9642-0
info@janitza.com | www.janitza.com