



- According to
 - Performance Level (PL) e and category 4 to EN ISO 13849-1: 2008
 - Safety Integrity Level (SIL 3) to IEC/EN 61508
- Safety radio transmission
- Radio receiver for:
 - Radio controlled enabling switch
 - Control signals for 6 non-safety semiconductor outputs
- Multifunction safety modul with additional control input to connect:
 - E-stop pushbutton (2-channel), safety gate or LC type 4 according to EN 61496
 - 1 Start button
 - 1 or 2 monitoring contacts to signal the use of radio
- Adjustable functions with step switch for:
 - Manual start or automatic start
 - when removing the enabling switch from the charger (open control contact) manual start is possible by enabling switch
 - possibility of disabling the access protection (gate) with active enabling switch
- Broken wire and short circuit monitoring with error indication
- Feedback circuit Y1/Y2 for monitoring of external contactors
- 2 semiconductor outputs for status indication
- LEDs for status indication
- Easy connection
- DIN rail mounting
- Removable terminal blocks allow fast exchange of module
- Also as input modul for multifunction, modular safety system SAFEMASTER M available
- Compact unit, only 67.5 mm width

Additional Information About This Topic

- Informations about the additional enabling switch see datasheet RE 6910

Approvals and Markings



Circuit Diagrams

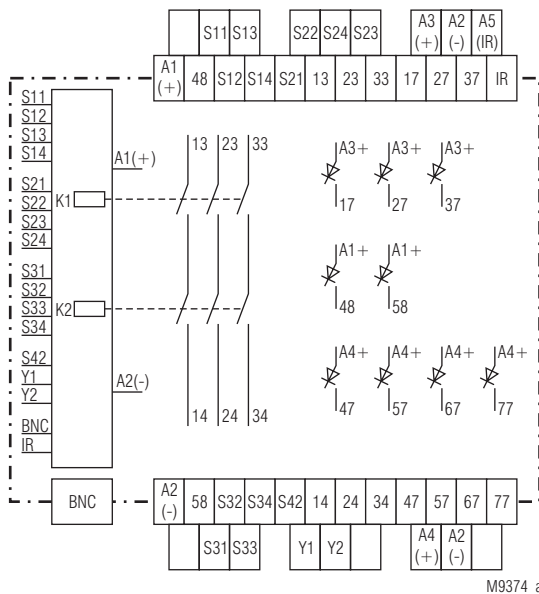

BI 6910.03/01MF9

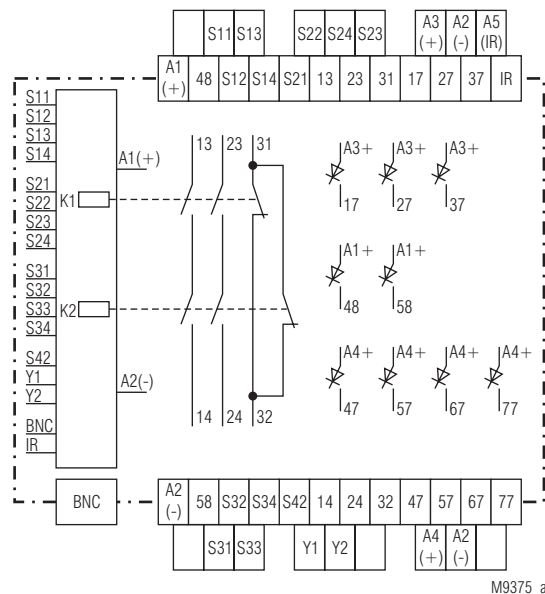

BI 6910.22/01MF9

Indication for Enabling Switch

The BI 6910 is equipped with a safety radio receiver to operate the signals from an enabling switch. It has 1 or 2 inputs depending on the operation mode (S31-S32 and S33-S34) to connect the indication contacts of a battery charger for the remote control.

Aerial Connection

The radio connection of the radio controlled safety module to the re-enabling switch is made via an aerial that is mounted directly on the front of the BI 6910. If the unit is built into a metal cabinet the aerial has to be mounted outside. The connection is made via DOLD coax cable (e.g. RE 5910/042; Article number: 0059653). Special functions like activity monitoring and selection of radio frequency can be adjusted on the enabling switch.

Indications

green LEDs K1 and K2:	on when safety relay activated
green LED reception:	on at radio receive
yellow LEDs run 1, run 2 and outputs 48 and 58:	indicate the actual status of the module
red LED receiver error:	indicate errors on radio-receiver



Notes

A machine must only be started from a location from which one can see that no person is present in the dangerous area.

To solve this there are 2 variants of the BI 5910:

BI 6910.__/00MF9

This unit is used in applications where start is only possible from a hard-wired start button.

BI 6910.__/01MF9

This unit has in addition to the radio control also an infrared function. The reset of the enabling switch is only accepted if the reset signal is received via radio and via infrared. This means that the enabling switch must be pointed at the infrared receiver for reset.

Technical Data

Radio	
Conformity:	ETS 300 220
Aerial:	1/4 λ aerial, plug in as accessory
Frequency:	64 programmable frequencies 433.1 ... 434.675 MHz
Sensitivity:	< -100 dBm
Nominal voltage U_N:	DC 24 V
Voltage range:	0.85... 1.15 U _N at max. 5% residual ripple max. 120 mA (Semiconductor outputs not connected)
Nominal consumption:	
Control voltage on S11, S13, S21, S23, S31, S33, 48, 58:	DC 23 V at U _N
Control current on S12, S14, S22, S24, S32, S34, S42:	each 4.5 mA at U _N
Max. voltage for active signals on: S12, S14, S22, S24, S32, S34, S42:	DC 16 V
Max. Voltage for inactive signals on: S12, S14, S22, S24, S32, S34, S42:	DC 9 V
Max. input voltage on S12, S14, S22, S24, S32, S34, S42:	DC 30 V
Fusing:	Internal with PTC
Max. time difference between input signals of one function	
E-stop, Light curtains:	250 ms
Gates:	3 s

Technical Data

Safety Output

Contacts

BI 6910.03:	3 NO contacts
BI 6910.22:	2 NO contacts, 1 NC contact
	The NC contact can only be used as indicator contact!!
	Relais, forcibly guided

Contact type:

Operating time typ. at U_N

automatic start:	max. 1000 ms
manual start:	max. 110 ms
automatic restart:	max. 70 ms

Switching off time (reaction time)

S12-S14, S22-S24, S32-S34:	max. 25 ms
E-stop (Radio):	max. 170 ms

Passive disconnection because of interrupted radio signal: max. 500 ms

Disconnection with active radio signal and closed charge control contact:

	adjustable from 5 to 30 s
--	---------------------------

Nominal output voltage:

	AC 250 V
	DC: see arc limit curve
	> 100 mV
	5 A

Switching of low loads:

Thermal current I_{th}:

Switching capacity

to AC 15

NO contacts:	AC 3 A /230 V	IEC/EN 60 947-5-1
NC contacts:	AC 2 A /230 V	IEC/EN 60 947-5-1
to DC 13:	DC 8 A / 24V at 0.1Hz	IEC/EN 60 947-5-1

Electrical life

to AC 15 at 2 A, AC 230 V: 100000 switching cycles IEC/EN 60 947-5-1

Permissible switching frequency: max. 1200 switching cycles / h

Short circuit strength

Max. fuse rating: 6 A gL IEC/EN 60 947-5-1

Line circuit breaker: C 8 A

Mechanical life: 10 x 10⁶ switching cycles

Semiconductor Outputs

Outputs

(terminals 48, 58, 17, 27, 37,

47, 57, 67, 77): transistor outputs, switching +

Nominal output voltage

(A3+, A4+): DC 24 V

Nom. output voltage at U_N: min. DC 23 V, max. 100 mA cont. current
max. 400 mA für 0.5 s internal short circuit, over temperature and overload protection

Min. operating current: min. 0.5 mA

Residual current: min. 0.1 mA

General Data

Operating mode: Continuous operation

Temperature range

operation: 0 ... 50°C

storage: - 25 ... + 85 °C

altitude: < 2.000 m

Clearance and creepage distance

rated impulse voltage /

pollution degree: 4 kV / 2 (basis insulation) IEC 60 664-1

EMC

HF-irradiation: 10 V / m IEC/EN 61 000-4-3

Fast transients

on wires for power supply A1-A2: 2 kV IEC/EN 61 000-4-4

on signal and control wires: 2 kV IEC/EN 61 000-4-4

Surge voltages

between wires for power supply 1 kV IEC/EN 61 000-4-5

between wire and ground: 2 kV IEC/EN 61 000-4-5

HF- wire guided: 10 V IEC/EN 61 000-4-6

Interference suppression: Limit value class B EN 55 011

Degree of protection: acc. to EN 61 496-1 (1997) the unit has to be mounted in a control cabinet with protection class 54

Housing: IP 40 IEC/EN 60 529

Terminals: IP 20 IEC/EN 60 529

Enclosure: Thermoplastic with V0 behaviour according to UL subject 94

Technical Data

Vibration resistance: according to EN 61496-1 (1997)
Amplitude 0.35 mm IEC/EN 60 068-2-6
Frequency 10 ... 55 Hz

Shock proof

Acceleration: 10g
Impulse length: 16 ms
Number of shocks: 1000 per axis on all 3 axes

Climate resistance: 0 / 050 / 04 IEC/EN 60068-1

Terminal designation: EN 50 005

Wire connection: 1 x 2.5 mm² strand. wire with sleeve or
1 x 4 mm² solid or
2 x 1.5 mm² stranded wire with sleeve
DIN 46 228-1/-2/-3/-4

Leiterbefestigung: Plus- minus- terminal screws M 3.5

box terminals with wire protection

Mounting: DIN-rail IEC/EN 60 715

Weight: 495g

Dimensions

Width x height x depth: 67.5 x 84 x 129 mm

Safety Related Data for E-STOP via wired e-stop button

Values according to EN ISO 13849-1:

Category:	4	
PL:	e	
MTTF _d :	> 100	a
DC _{avg} :	98.4	%
d _{op} :	365	d/a (days/year)
h _{op} :	24	h/d (hours/day)
t _{Zyklus} :	3.60E+03	s/Zyklus
	≅ 1	/h (hour)

Values according to IEC/EN 61508:

SIL	3	IEC/EN 61508
HFT ¹⁾ :	1	
DC _{avg} :	98.4	%
SFF	99.5	%
PFH _D :	1.20E-9	h ⁻¹

Safety Related Data for E-STOP via radio control

Values according to EN ISO 13849-1:

Category:	4	
PL:	e	
MTTF _d :	> 100	a
DC _{avg} :	98.0	%
d _{op} :	365	d/a (days/year)
h _{op} :	24	h/d (hours/day)
t _{Zyklus} :	2	h (hours)

Values according to IEC/EN 61508:

SIL	3	IEC/EN 61508
HFT ¹⁾ :	1	
DC _{avg} :	98.4	%
SFF	99.5	%
PFH _D :	2E-9	h ⁻¹

¹⁾ HFT = Hardware-Failure Tolerance



The values stated above are valid for the standard type.

Safety data for other variants are available on request.

The safety relevant data of the complete system has to be determined by the manufacturer of the system.

Standard Types

BI 6910.22/00MF9 DC 24 V

Article number: 0062571

Safety outputs: 2 NO contacts, 1 NC contact^{*)}

BI 6910.03/00MF9 DC 24 V

Article number: 0062570

Safety outputs: 3 NO contacts

- Function with rotational switches adjustable
- Nominal voltage U_N: DC 24 V
- Width: 62.5 mm

^{*)} The NC contact can only be used as indicator contact!

Ordering Example

BI 6910 _ _ /0_ MF9 _ _

Special behaviour:

00¹⁾: for enabling switch at command- or function mode with max. 8 functions (F1-F8) on 6 outputs of 1 receiver

01: Special version for enabling switch at function mode with max. 8 functions (F2-F9) on 6 outputs of 1 receiver

10: max. 10 functions on 6 outputs of 1 receiver

11: Pairs of 2 receivers with the same identity code for max. 10 functions on 12 outputs

12: Pairs of 2 receivers with the same identity code for max. 10 functions on 12 outputs

Option start by infrared

0: without start by infrared

1: with start by infrared

Contacts

.03: 3 NO contacts

.22: 2 NO contacts, 1 NC contacts²⁾

Type

¹⁾ The designation „00“ can be dropped

²⁾ The NC contact is not a safety contact

Accessories

RE 6910/001: Enabling switch 1 mW 64 channels
Article number: 0062631

RE 6910/002: Enabling switch 10 mW 25 channels
Article number: 0063283

RE 5910/040: 1/4 λ aerial 433 - 434 MHz - BNC
Article number: 0059573

RE 5910/041: 1/2 λ aerial 433 - 434 MHz - BNC
Article number: 0059652

RE 5910/042: 2 m extension for aerial + trough hole connector - BNC fixing angle
Article number: 0059653

RE 5910/043: 5 m extension for aerial + trough hole connector - BNC fixing angle
Article number: 0059654

RE 5910/045: Extension 50 cm
Article number: 0059656

RE 5910/046: 90° adapter for aerial
Article number: 0061685

RE 5910/060: 1 infra red receiver with 10 m wire
Article number: 0059665

RE 5910/061: 10 m extension wire for infra red module
Article number: 0059666

Characteristics

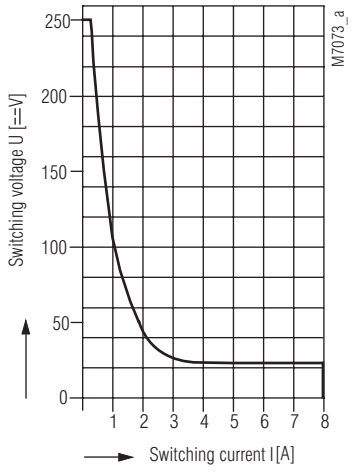

Safe breaking, no continuous arcing
under the curve, max. 1 switching cycle/s

Arc limit curve

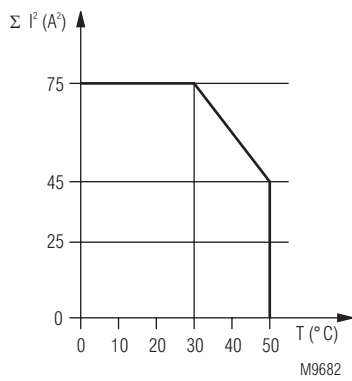

Quadratic total current

$$\Sigma I^2 = I_1^2 + I_2^2 + I_3^2$$

I_1, I_2, I_3 - current in contact paths

Quadratic total current limit curve