

Short Description

The Wireless E-Stop-System includes a very compact and ergonomic remote control RE 5910 and a safety module with radio control BI 5910. The remote control provides personal protection when entering dangerous areas and allows besides the emergency stop function also control functions with the integrated push buttons and switches. The safety outputs of the BI 5910 guarantee safe disconnection. For control functions it includes 7 semiconductor outputs.

The System Components

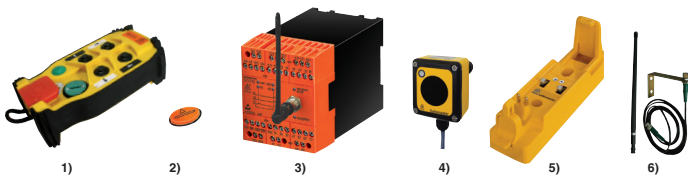

Remote control ¹⁾

The remote control includes 1 e-stop and 1 start button as well as 4 function buttons for radio remote control. It does not replace conventional safety circuits, but offers additional features. I.e. wired safety circuits remain active, although a remote control is used.

Electronic Key for Remote Control ²⁾

The electronic key enables the activation of the remote control and offers personal access permission to a certain configuration of the remote control. It contains the following information:

- Frequency that is used for transmission
- Identity code of the system
- Time interval for activity monitoring

Radio Controlled Safety Module BI 5910 ³⁾

The radio safety module reacts on the signals of the corresponding remote control and the wired safety components. To detect the corresponding remote control frequency and identity code must be identical.

Infrared Module RE 5910/060 ⁴⁾

If the start of a plant must only be possible from a certain area, e. g. to have a view on the dangerous zone, the option with infrared start is the ideal solution. Accidents can be avoided by starting from defined zones.

Charger Station RE 5910/010 ⁵⁾

If the remote control is not used it has to be placed in the charger and switched off. This starts the charging process for the battery. The charger has 2 monitoring contacts. These are used to detect the removal of the remote control.

Aerials ⁶⁾

The receiver unit requires an aerial that can be mounted directly on the front of BI 5910. If the receiver is mounted in a metal enclosure the aerial has to be placed outside. For the outside mounting a special coaxial cable is available.

Your Advantages

- Ideal solutions for mobile and stationary machines and plants with dangerous areas
 - During automatic operation e. g. to clear failures
 - During set up e. g. to adjust machine parameters, maintenance, set up
- Higher availability of machines because damage of trailing cables is avoided
- Less mounting, installation and wiring time
- No wearing on trailing cables, slip rings etc.
- Easy retrofit and modernising of machines
- Optimised sight on operating area during set up
- User legitimating with electronic key on remote control possible

Features

Total System

- According to
 - Performance Level (PL) e and category 4 to EN ISO 13849-1: 2015
 - Safety Integrity Level (SIL 3) to IEC/EN 61508
- Applicable in the scope of the EN 60204-1 as well as in emergency stop applications according to EN ISO 13850
- Safety radio transmission
- Radio receiver for:
 - E-stop
 - Control signals for 6 non-safety semiconductor outputs

Radio Controlled Safety Module

- Adjustable functions with step switch for:
 - Manual start or automatic start
 - When removing the remote control from the charger (open control contact) manual start is possible by remote control
 - Possibility of disabling the access protection (gate) with active remote control
- Broken wire and short circuit monitoring with error indication
- Feedback circuit Y1/Y2 for monitoring of external contactors
- 2 semiconductor outputs for status indication
- Removable terminal blocks allow fast exchange of module
- Compact unit, only 67.5 mm width

Remote control

- Comfortable single hand operation
- Options with 4 configurable push buttons or rotational switches for control functions
- With perceptible 2 step push buttons
- With marking space besides the push buttons
- Protection against unintentional activation
- Speed charging and high battery capacity
- Fast change of frequency
- Pocket for remote control as option

Additional Information About This Topic

- You will find more information about the Wireless E-Stop-System in the User Manual

Approvals and Markings



Applications

E-Stop

Protection of men and machines in mobile and large plants where a fixed wiring is not possible, e.g. production halls, mounting scaffolds, plants and dangerous accessible areas.

Also for control functions for e. g. :

- Step control
- Start-stop functions
- Speed adjustment
- Positioning and actuator selection

Circuit Diagrams

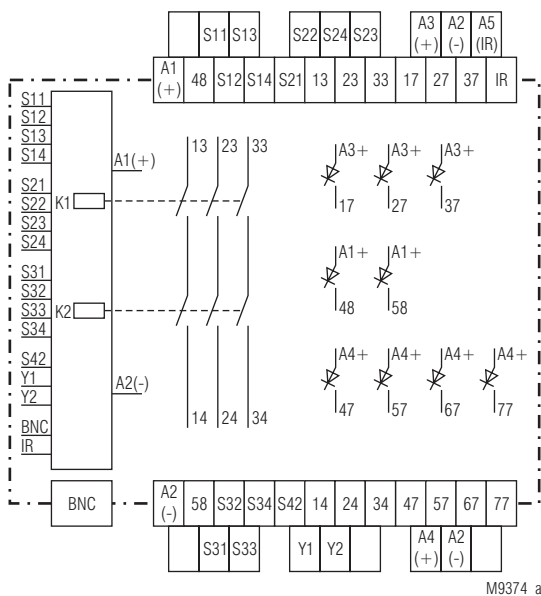

M9374_a

BI 5910.03/00MF9

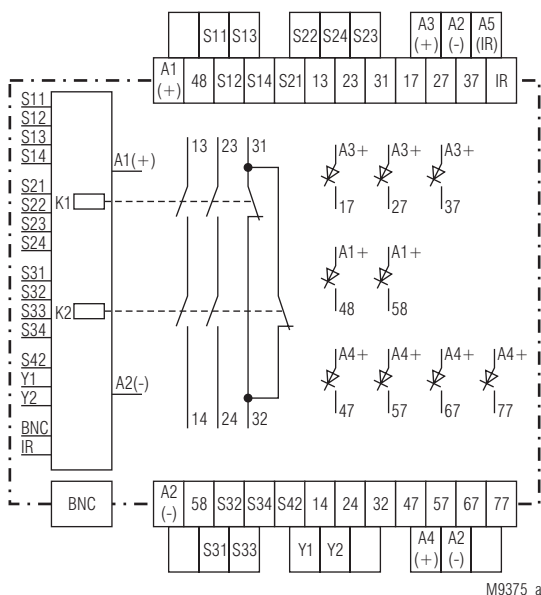

M9375_a

BI 5910.22/00MF9

Indication for Remote Control

The device is equipped with a safety radio receiver to operate the signals from a remote control with remote e-stop. It has 1 or 2 inputs depending on the operation mode (S31-S32 and S33-S34) to connect the indication contacts of a battery charger for the remote control.

Aerial Connection

The radio connection of the radio controlled safety module to the remote control is made via an aerial that is mounted directly on the front of the BI 5910. If the unit is built into a metal cabinet the aerial has to be mounted outside. The connection is made via DOLD coax cable (e.g. RE 5910/042; Article number: 0059653).

Special functions like activity monitoring and selection of radio frequency can be adjusted on the remote control.

Connection Terminals

Terminal designation	Signal description
A1+	DC 24 V; Supply voltage for radio controlled safety module
A2	Common ground
A3+	DC 24 V; Voltage supply of semiconductor outputs
A5+	Voltage output DC 12 V
S11/S12	Input 1 for 1 st emergency stop or LC
S13/S14	Input 2 for 1 st emergency stop or LC
S21/S22	Input 1 for 2 nd emergency stop or LC
S23/S24	Input 2 for 2 nd emergency stop or LC
S31/S32	1 st control input for charger unit
S33/S34	2 nd control input for charger unit
S42	Input for hard-wired start button
13/14	1 st safety output, NO safety contact
17	Non safe static output Mode 0 to 4 and 8,9: Activated without remote control Mode 5,6 and 7: Activation on start button of remote control
23/24	2 nd safety output, NO safety contact
27, 37, 47, 57, 67, 77	Non-safety semi-conductor outputs, assignment to push buttons / switches of remote control depending on selected model
31/32	Monitoring output NC contact only for contact variant .22
33/34	3 rd safety output, NO safety contact only for contact variant .03
48/58	Non-safety semiconductor outputs 24 V: State of radio-controlled safety module
Y1/Y2	Input for feed back loop of external contact amplifier
IR	Input signal

Indications

Green LEDs K1 and K2:	On, when safety relay activated
Green LED reception:	On, at radio receive
Yellow LEDs run 1, run 2 and outputs 48 and 58:	Indicate the actual status of the module
Red LED receiver error:	Indicate errors on radio-receiver

Notes

A machine must only be started from a location from which one can see that no person is present in the dangerous area.

To solve this there are 2 variants of the BI 5910:

BI 5910.__/00MF9

This unit is used in applications where start is only possible from a hard-wired start button.

BI 5910.__/01MF9

This unit has in addition to the radio control also an infrared function. The reset of the remotecontrol is only accepted if the reset signal is received via radio and via infrared. This means that the remote control must be pointed at the infrared receiver for reset.

A visible e-stop button must be active all the time.

This means that the e-stop button of the remote control must not be visible when it is inactive. Therefore the charger must be mounted in a way that the remote control is not visible while charging.

Radio

Conformity:	ETS 300 220
Aerial:	1/4 aerial, plug in as accessory
Frequency:	64 programmable frequencies 433.1 ... 434.675 MHz
Sensitivity:	< -100 dBm
Nominal voltage U_N:	DC 24 V
Voltage range:	0.85... 1.15 U _N at max. 5% residual ripple
Nominal consumption:	Max. 120 mA (Semiconductor outputs not connected)
Control voltage on S11, S13, S21, S23, S31, S33,48, 58:	DC 23 V at U _N
Control current on S12, S14, S22, S24, S32, S34, S42:	Each 4.5 mA at U _N
Max. voltage for active signals on: S12, S14, S22, S24, S32, S34, S42:	DC 16 V
Max. Voltage for inactive signals on: S12, S14, S22, S24, S32, S34, S42:	DC 9 V
Max. input voltage on S12, S14, S22, S24, S32, S34, S42:	DC 30 V
Fusing:	Internal with PTC
Max. time difference between input signals of one function	
E-stop, Light curtains:	250 ms
Gates:	3 s

Safety Output

Contacts

BI 5910.03:	3 NO contacts
BI 5910.22:	2 NO contacts, 1 NC contact The NC contact can only be used as indicator contact!! Relais, forcibly guided

Contact type:

Operating time typ. at U_N

automatic start: max. 800 ms	
manual start:	Max. 110 ms
automatic restart:	Max. 70 ms

Switching off time (reaction time)

S12-S14, S22-S24, S32-S34:	Max. 25 ms
E-stop (Radio):	Max. 170 ms
Passive disconnection because of interrupted radio signal:	Max. 500ms

Disconnection with active radio

signal and closed charge

control contact: Max. 1 s

Nominal output voltage:
AC 250 V
DC: see arc limit curve
> 100 mV

Switching of low loads:

Thermal current I_{th}: 5 A

Switching capacity to AC 15

NO contacts:	AC 3 A / 230 V	IEC/EN 60947-5-1
NC contacts:	AC 2 A / 230 V	IEC/EN 60947-5-1
to DC 13:	DC 8 A / 24 V at 0.1Hz	IEC/EN 60947-5-1

Electrical life

to AC 15 at 2 A, AC 230 V: 10⁵ switching cycles IEC/EN 60947-5-1

Permissible switching frequency: Max. 1200 switching cycles / h

Short circuit strength

Max. fuse rating: 6 A gG / gL IEC/EN 60947-5-1

Line circuit breaker: C 8 A

Mechanical life: 10 x 10⁶ switching cycles

Semiconductor outputs

Outputs (terminals 48, 58, 17, 27, 37, 47, 57, 67, 77):	Transistor outputs, switching +
Nominal output voltage (A3+, A4+):	DC 24 V
Nom. output voltage at U _N :	Min. DC 23 V, max. 100 mA cont. current max. 400 mA für 0.5 s internal short circuit, over temperature and overload protection
Min. operating current:	Min. 0.5 mA
Residual current:	Min. 0.1 mA

General Data

Operating mode:	Continuous operation	
Temperature range	operation: 0 ... 50°C storage : - 25 ... + 85 °C	
altitude:	< 2000 m	
Clearance and creepage distance	Rated impulse voltage / pollution degree: 4 kV / 2 (basis insulation) IEC 60664-1	
EMC	HF-irradiation: 10 V / m IEC/EN 61000-4-3	
Fast transients		
on wires for power supply A1-A2:	2 kV	IEC/EN 61000-4-4
on signal and control wires:	2 kV	IEC/EN 61000-4-4
Surge voltages		
between wires for power supply	1 kV	IEC/EN 61000-4-5
between wire and ground:	2 kV	IEC/EN 61000-4-5
HF- wire guided:	10 V	IEC/EN 61000-4-6
Interference suppression:	Limit value class B	EN 55011
Degree of protection:	Acc. to EN 61496-1 (1997) the unit has to be mounted in a control cabinet with protection class 54	
Housing:	IP 40	IEC/EN 60529
Terminals:	IP 20	IEC/EN 60529
Enclosure:	Thermoplastic with V0 behaviour according to UL subject 94	
Vibration resistance:	according to EN 61496-1 (1997) Amplitude 0.35 mm IEC/EN 60068-2-6 Frequency 10 ... 55 Hz	
Shock proof		
Acceleration:	10 g	
Impulse length:	16 ms	
Number of shocks:	1000 per ax is on all 3 axes	
Climate resistance:	0 / 050 / 04	IEC/EN 60068-1
Terminal designation:	EN 50005	
Wire connection:	1 x 2.5 mm ² strand. wire with sleeve or 1 x 4 mm ² solid or 2 x 1.5 mm ² stranded wire with sleeve DIN 46228-1/-2/-3/-4	
Wire fixing:	Plus- minus- terminal screws M 3.5 box terminals with wire protection	
Mounting:	DIN rail	IEC/EN 60715
Weight:	495 g	

Dimensions

Width x height x depth: 67.5 x 84 x 129 mm

Standard Types Radio Controlled Safety Module BI 5910

BI 5910.22/00MF9	DC 24 V
Article number:	0059002
Safety outputs:	2 NO contacts, 1 NC contact*)
BI 5910.03/00MF9	DC 24 V
Article number:	0059003
Safety outputs:	3 NO contacts

- Function with rotational switches adjustable
- Nominal voltage U_N: DC 24 V
- Width: 62.5 mm

*) The NC contact can only be used as indicator contact!

Technical Data Remote Control RE 5910

Radio

Conformity:	ETS 300 220
Carrier frequency:	UHF, frequency modulated (FM)
Frequency:	64 programmable frequencies
Frequency range:	433.1 ... 434.675 MHz
HF-power:	< 10 mW (without licence), integrated aerial
Distance:	Approx. 150- 200 m under industrial ambient conditions ^{*)} , approx. 600 m in open area

^{*)} The distance can vary with the ambient conditions of the remote control and the receiver aerial (roof construction, metal walls etc.)

Battery

Type:	Lithium-ion
Service life:	Min. 500 cycles (charge/discharge cycles)
Charging time:	2 h, bei + 20 °C (80 %) (for completely discharged battery)
Full charging time:	2 h 30 min (100 %)

Charge capacity

- Normal operation of push buttons:	20 h, at 50 % operation and + 20 °C
- After 10 minutes charging of discharged battery:	approx. 1 h
Storage temperature:	- 20 °C ... + 50 °C
Charging temperature:	0 °C ... + 40 °C

Attention! Slow charging outside temperature range may damage the battery

Enclosure

Material:	ABS
Degree of protection:	IP 65
Ambient temperature:	- 20°C ... + 50 °C
Holder for non-operation:	Charger unit
Weight (with battery):	240 g

Dimensions

Width x height x depth: 46 x 78 x 143 mm

Standard Type Remote Control RE 5910

RE 5910/001

Article number: 0060610

- With 4 2 step push buttons
- Without infrared
- With electronic key

Ordering Example

BI 5910 . . . /0_MF9 DC 24 V

Nominal voltage
Option start by infrared
0: without start by infrared
I: with start by infrared

Contacts
.03: 3 NO contacts
.22: 2 NO contacts, 1 NC contacts^{*)}
Type

^{*)}The NC contact is not a safety contact

RE 5910/00

Variant

- 1: with 4 2 step push buttons, without IR
 - 2: with 4 2 step push buttons, with IR
 - 3: with 4 1 step push buttons, without IR
 - 4: with 4 1 step push buttons, with IR
 - 5: B1-B3: step push button (BPSV),
B4: rotational switch with auto return (COM3R)
 - 6: B1-2: 1 step pushbutton (BPSV),
B3-B4: rotational switch (COM3), with IR
 - 7: B1-B2: 1 step pushbutton (BPSV)
B3-B4: rotational switch (COM3),
without IR, with electronic key
 - 8: B1-B2: 2 step pushbutton (BPDV)
B3-B4: rotational switch (COM2),
without IR, without electronic key
- 9114: B1-B3: 1 step pushbutton (BPSV),
B4: rotational switch (COM3), with IR

others on request

Characteristics Radio Controlled Safety Module BI 5910

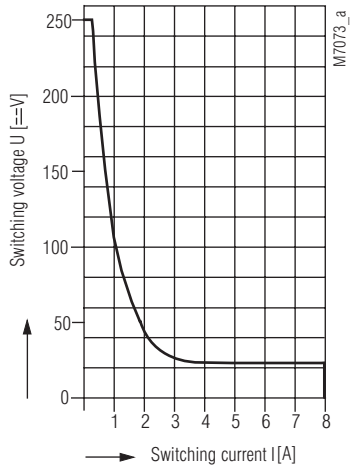

Safe breaking, no continuous arcing
under the curve, max. 1 switching cycle/s

Arc limit curve

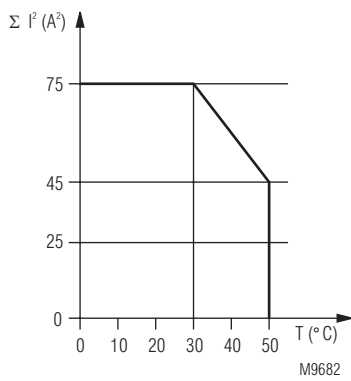

Quadratic total current

$$\Sigma I^2 = I_1^2 + I_2^2 + I_3^2$$

I_1, I_2, I_3 - current in contact paths

Quadratic total current limit curve

Technical Data Power supply AC 230 V RE 5910/011 and RE 5910/013

Input

Nominal voltage:	AC 230 V
Voltage range:	AC 90 ... 264 V
Efficiency:	> 70 %

Output

Voltage:	DC 5 V
Voltage control:	4.8 - 5.2 V
Residual ripple:	< 150 mV p-p 100 Hz
Output current:	0 ... 1 A
Power:	5 W
Input control:	< 0.1 %
Load control:	< 1 % von 0 bis Vollast
Overload protection:	Typ. 110 %

General Data

Nominal operating mode:	Continuous operation
Temperature range:	- 10 ... + 40 °C
Insulation class:	II
EMC	
EMC irradiation:	According to EN 61000-6-3, FCC15B
EMC proof:	According to EN 61000-6-1

Weight:	65 g
---------	------

Dimensions

Length x width x height:	75 x 32 x 40 mm
---------------------------------	-----------------

Standard Type Power supply AC 230 V RE 5910/011 and RE 5910/013

RE 5910/011	EU plug
Article number:	0060617

RE 5910/013	UK plug
Article number:	0061323

Plug Variants Power supply AC 230 V RE 5910/011 and RE 5910/013

plug EU RE5910/011

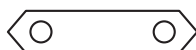

plug UK RE5910/013

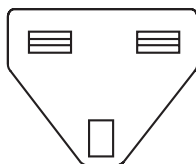

M11197



RE 5910/011



Charger Station

Technical Data Power supply DC 24 V RE 5910/012

Input

Nominal voltage:	DC 24 V
Voltage range:	DC 18 ... 36 V
Input current:	0.9 A / DC 24 V
Efficiency:	> 70 %

Output

Voltage:	DC 5 V
Voltage control:	4.75 - 5.5 V
Residual ripple:	< 100 mV p-p
Output current:	0 ... 3 A (see derating curve)
Power:	15 W
Input and load control:	± 0.5 %
Overload protection:	105 % ... 160 % selfrecovering when failure removed
Overvoltage protection:	5.75 V ... 6.75 V

General Data

Nominal operating mode:	Continuous operation
Temperature range:	- 10 ... + 55 °C (see derating curve)
Insulation class:	II

EMC and protection

Input / Output:	2 kV AC
Input / Earth:	1 kV AC
Output / Earth:	0.5 kV AC
Insulating resistance:	
Input / Output, Input / Earth, Output / Earth:	100 MΩ / 500 V DC / 25 °C / 70 % RH
EMC irradiation:	According to EN 55022 (CISPR22)
EMC proof:	According to EN 61000-4-2,3,4,6,8 EN 55024 light industry level, criteria A

Weight:	200 g
---------	-------

Dimensions

Width x height x depth:	91 x 51 x 37 mm
--------------------------------	-----------------

Standard Type Power supply DC 24 V RE 5910/012

RE 5910/012	Power supply for industrial charger
Article number:	0060618

Characteristic Power supply DC 24 V RE 5910/012

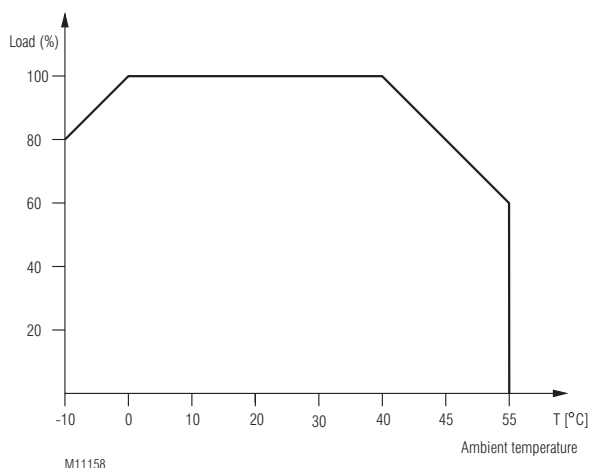

Derating curve

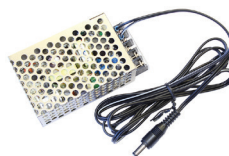

RE 5910/012



Charger Station

Accessories

RE 5910/010:	Industrial charger unit Article number: 0060616
RE 5910/011:	Power supply for charger AC 230 V (Euro connector) Article number: 0060617
RE 5910/012:	Power supply for charger DC 24 V Article number: 0060618
RE 5910/013:	Power supply for charger AC 230 V (U.K. connector) Article number: 0061323
RE 5910/030:	Set with 6 colour stickers "movements" for 2-step push buttons Article number: 0059660
RE 5910/031:	Set with 90 black and white stickers Article number: on request
RE 5910/033:	Set with 48 white stickers + 48 transparent protection stickers for individual marking Article number: 0059663
RE 5910/040:	1/4 λ aerial 433 - 434 MHz - BNC Article number: 0059573
RE 5910/041:	1/2 λ aerial 433 - 434 MHz - BNC Article number: 0059652
RE 5910/042:	2 m extension for aerial + trough hole connector - BNC fixing angle Article number: 0059653
RE 5910/043:	5 m extension for aerial + trough hole connector - BNC fixing angle Article number: 0059654
RE 5910/045:	Extension 50 cm Article number: 0059656
RE 5910/046:	90° adapter for aerial Article number: 0061685
RE 5910/051:	Replacement rechargeable battery Article number: 0060621
RE 5910/060:	1 infra red receiver with 10 m wire Article number: 0059665
RE 5910/061:	10 m extension wire for infra red module Article number: 0059666
RE5910/070:	Remote control holster for RE5910; Material: leather, - Metal clip to fix it on belt. - With rings to clip in the personal mounting harness RE 5910/071 Article number: 0060490
RE 5910/071:	Personal mounting harness with elastic straps to carry the remote control in the holster RE5910/070 on the body of the operator. Article number: 0060491

Elektronische Ersatzschlüssel

RE 5910/020:	Grüner elektronischer Schlüssel, programmiert Artikelnummer: 0060619
RE 5910/021:	Orangefarbener elektronischer Schlüssel, programmiert Artikelnummer: 0060620

Electrical replacement key

RE 5910/020:	Green electronic key with program Article number: 0060619
RE 5910/021:	Orange electronic key with program Article number: 0060620

Important:	Please state the following details on order: <ul style="list-style-type: none">• Number of electronic key (6 figure number, noted on page 2 of this manual)• Frequency channel, if it should be programmed by manufacturer• Time delay for activity control (01-99 sec or 01-98 min)
-------------------	--

