

# EX系列适配器 用户手册

德克威尔 · 工业智造可靠伙伴



网址: [www.wellinkio.com](http://www.wellinkio.com)

邮箱: [sales@wellinkio.com](mailto:sales@wellinkio.com)

地址: 南京市浦口区兰新路19号瑞创智造园13号楼

# Preface

## ■ Information introduction

Thank you for purchasing the DECOWELL EX series card-type I/O module!

The EX series card-type I/O module is a distributed expansion module developed by DECOWELL. This series of modules consists of adapters, I/O modules, power modules, and terminal modules. The adapter can support a variety of communication buses, such as PROFINET, EtherCAT, DeviceNet, Modbus RTU, PROFIBUS-DP, etc. I/O modules can be divided into digital input modules, digital output modules, analog input modules, analog output modules and function modules. Users can match them according to actual applications.

EX-1130 is a Modbus TCP bus adapter, each module can be expanded to up to 32 input and output modules.

This manual mainly describes the specifications, features and usage of this module. Please read it carefully before use in order to use this product more clearly and safely.

# CONTENTS

Preface .....	2
Safety Precautions .....	6
1. Product Information .....	9
1.1 Product naming and nameplates .....	9
1.2 Parts Description .....	10
1.3 Technical specifications .....	13
1.4 Environmental regulations .....	14
1.5 EX-1130 Adapter usage .....	15
1.5.1 IP address settings .....	15
1.5.2 Supported function codes .....	18
1.5.3 I/O module occupied bits or byte length description .....	18
1.5.4 I/O module bits and register address .....	19
2. Mechanical installation .....	20
2.1 Installation dimensions .....	20
2.2 Installation method .....	20

2.2.1	Installation between modules .....	20
2.2.2	Installation on guide rail .....	22
<b>3.</b>	<b>Electrical Installation .....</b>	<b>23</b>
3.1	Cable selection.....	23
3.2	terminal wiring.....	24
<b>4.</b>	<b>Adapter configuration case.....</b>	<b>25</b>
4.1	Codesys and EX-1130 connections and configuration.....	25
4.1.1	Communication connection diagram.....	25
4.1.2	Hardware configuration.....	25
4.1.3	I/O module address description.....	26
4.1.4	New project and configuration.....	27
4.1.5	Bus exception output settings .....	29
4.2	Siemens S7-1500 with EX-1130 connections and configuration.....	30
4.2.1	Communication connection diagram.....	30
4.2.2	Hardware configuration.....	30
4.2.3	I/O module address description.....	31

---

4.2.5 New project and equipment configuration .....	32
4.2.6 Bus exception output settings .....	35
5. Product usage FAQ.....	37
Module usage issues.....	37
Network communication problems.....	37
6. Appendix.....	39
EX-1130 address table.....	39

# Safety Precautions

## ■ Security Statement

01. When installing, operating, and maintaining the product, please read and abide by these safety precautions.
02. To ensure personal and equipment safety, when installing, operating and maintaining the product, please follow the signs on the product and all safety precautions described in the manual.
03. The "tips", "notice", "warn" and "danger" items in the manual do not represent all the safety matters that should be followed, but are only a supplement to all safety precautions.
04. This product should be used in an environment that meets the design specifications. Otherwise, it may cause malfunctions. Functional abnormalities or component damage caused by failure to follow relevant regulations are not covered by the product quality guarantee.
05. Deckerwill does not bear any legal responsibility for personal safety accidents, property losses, etc. caused by illegal operation of products.

## ■ Security level definition

### Tips

This mark means "necessary additions or clarifications to the description of the operation."

### Notice

This mark states "Danger caused by failure to operate as required, which may result in mild or moderate personal injury and equipment damage."



This mark indicates "danger caused by failure to operate as required, which may result in personal injury or death."

### ■ When designing the control system warn

01. Please be sure to design a safety circuit when applying to ensure that the control system can still work safely when the external power supply is powered off or the expansion module fails;
02. When overcurrent occurs for a long time due to exceeding the rated load current or load short circuit in the output circuit, the module may smoke or catch fire. Safety devices such as fuses or circuit breakers should be installed externally.

### ■ When designing the control system Notice

01. Be sure to set up emergency braking circuits, protection circuits, interlock circuits for forward and reverse operations, and position upper and lower limit interlock switches to prevent machine damage in the external circuit of the expansion module;
02. In order to ensure that the equipment can operate safely, please design external protection circuits and safety mechanisms for output signals related to major accidents;
03. When the output units such as relays and transistors of the expansion module are damaged, their output cannot be controlled to the ON or OFF state;

04. The expansion module is designed to be used indoors and in an electrical environment with overvoltage level II. The power supply system level should have a lightning protection device to ensure that lightning overvoltage is not applied to the power input terminal, signal input terminal, and control output terminal of the expansion module. Wait for the port to avoid damaging the device.

05. Be sure to set up emergency braking circuits, protection circuits, interlock circuits for forward and reverse operations, and position upper and lower limit interlock switches to prevent machine damage in the external circuit of the expansion module;

06. In order to ensure that the equipment can operate safely, please design external protection circuits and safety mechanisms for output signals related to major accidents;

07. When the output units such as relays and transistors of the expansion module are damaged, their output cannot be controlled to the ON or OFF state;

08. The expansion module is designed to be used indoors and in an electrical environment with overvoltage level II. The power supply system level should have a lightning protection device to ensure that lightning overvoltage is not applied to the power input terminal, signal input terminal, and control output terminal of the expansion module. Wait for the port to avoid damaging the device.

# 1. Product Information

## 1.1 Product naming and nameplates

# EX-1130

① ②

Serial number	Name	Explain the definition
①	EX series	Card Type IO
②	bus adapter	Modbus TCP bus adapter

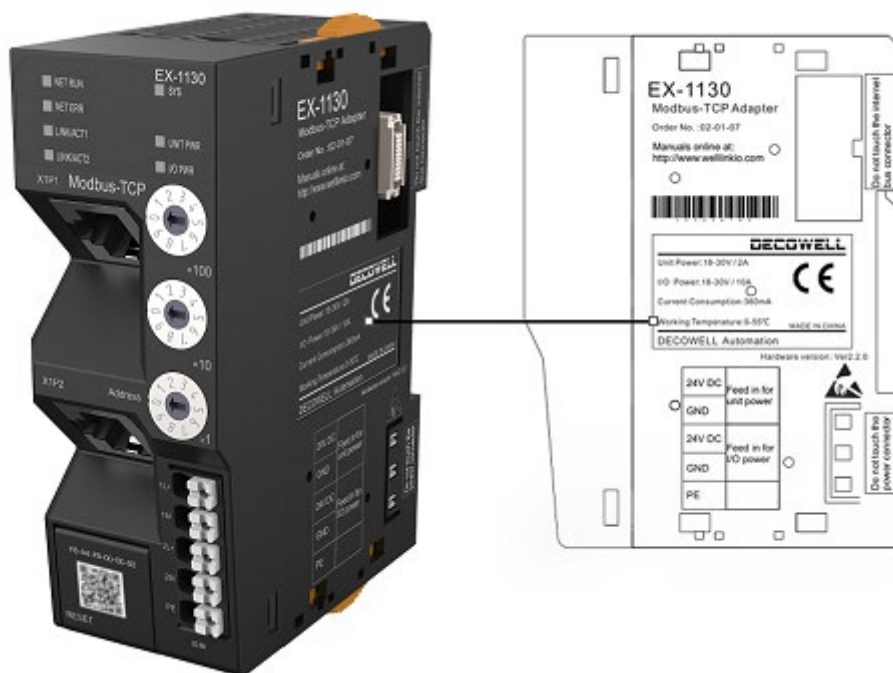

## 1.2 Parts Description

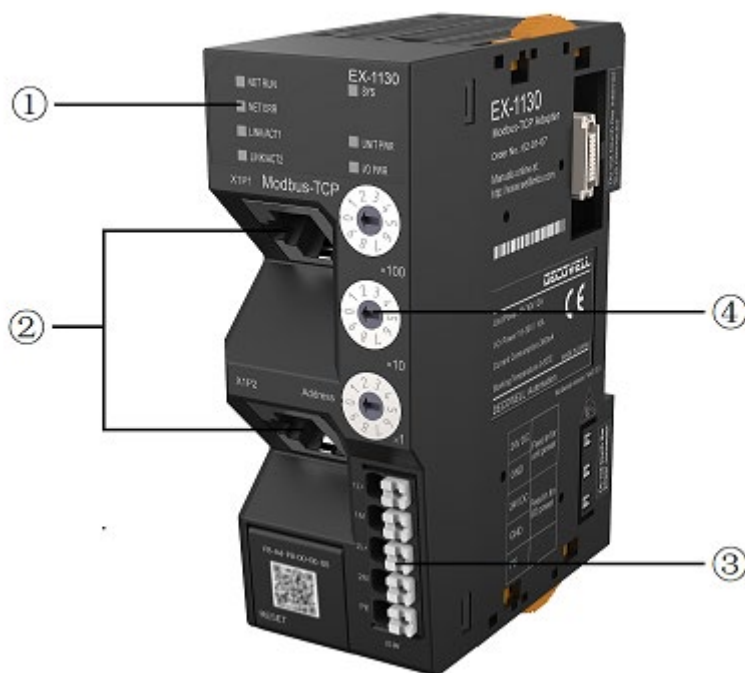

Figure 1-2-1 Parts description diagram

## Parts instruction sheet

Serial No.	Name	Function definition			
1	Status Indicator	RUN	Running lights	bright (green)	The TCP client is connected and communication is normal
		ERR	Fault indicator	bright (red)	No link
				Flashing (red)	The link is OK, but there is no valid communication to the TCP client
		SYS	System indicator light	1Hz frequency flashing (green)	The IO module is running normally

			5Hz frequency flashing (green)	Some or all IO modules are pulled out
			flicker and fade	Some or all IO modules failed to initialize
			Two flashes and one out	Some or all IO module configuration parameters are incorrect
			Off	Some or all IO modules are incompatible with the backplane
	UNIT PWR	System power indicator light	bright (green)	System power supply is normal
			Off	System power supply is not connected or faulty
	I/PWR	IO power indicator light	bright (green)	IO power supply is normal
			Off	The IO power supply is not connected or fault
	LINK/A CT1	Network port indicator1	bright (orange)	Network connection is normal
			Off	The network is not connected or abnormal
			Flashing (orange)	The network connection is normal and data is being exchanged
	LINK/A CT2	Network port indicator1	bright (orange)	Network connection is normal
Off (orange)			The network is not connected or abnormal	
Flashing (orange)			The network connection is normal	

					and data is being exchanged
2	RJ45 interface	Modbus TCP input and output port, can be connected to the Modbus of the subsequent stage TCP slave			
3	power port	Adapter input power (1L+, 1M)/IO module input power supply (2L+, 2M)			
4	IP address dialing			IP address hundred digit dial code	(valid range 0-2)
				IP address ten-digit dial code	(valid range 0-9)
				IP address single digit dialing	(valid range 0-9)

Note: The adapter factory default IP address: 192.168.1.10. The dial code only modifies the last digit of the IP address. For more settings, please refer to [1.5EX-1130Adapter usage](#).

## 1.3 Technical specifications

Basic parameters	
Dimensions	90×67×34mm
Operating temperature	0~55℃
storage temperature	-20~+85℃
Relative humidity	95% no condensation
Protection level	IP20
Wiring specifications	0.2~1.5mm <sup>2</sup>
Wiring	No screws
Power parameters	
System side power input	DC24V (18~36)
System side provides current	2A (Max)
IOPort side power input	DC24V (±20%)
IOPort side output current	10A (Max)
System side electrical isolation	AC500V
Power protection	Overcurrent protection, overvoltage protection, anti-reverse connection protection
Software parameters	
Bus protocol	Modbus TCP
Communication rate	100Mbps
Transmission distance	100m(distance between stations)
Input/output maximum bytes	Input: 512 Byte/Output: 512 Byte

Maximum number of client connections	8
--------------------------------------	---

## 1.4 Environmental regulations

Environmental parameters	
Operating temperature	0~55℃
Working humidity	95% no condensation
atmosphere	≥795 hPa (altitude ≤ 2000 m) as per IEC 61131-2
storage temperature	-20~+85℃
Overvoltage category	I



### Notice

- The controller is connected to EX-1130 through a switch. It is recommended to use a standard industrial Ethernet switch to prevent equipment abnormalities caused by problems such as the switch network.
- Some switches have BSP and QoS function, certain network interference can be handled in some environments. If there are switch cascades on site, BSP function must be turned on.

## 1.5EX-1130Adapter usage

### 1.5.1IP address settings

#### ① IP setting instructions

Dial combination value (decimal)	IP address
000	(Factory IP address) Default IP address: 192.168.1.10
001-254	Last digit of the IP address
>254	Out of the valid range of IP address setting, the ERR indicator light flashes.

#### ② Set IP address through software

Open the Decowell IOTesterTool software.

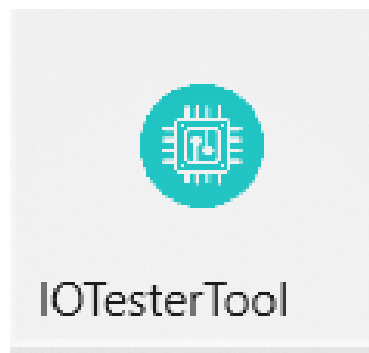

Click on the selected area in the image below to create a new project.



Right-click the created project and click "Scan Adapters".

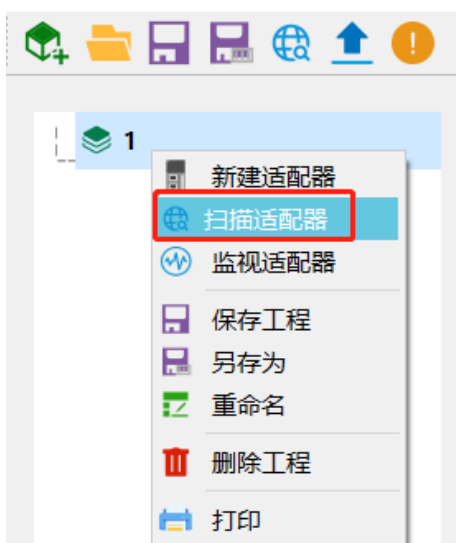

After selecting the communication mode, scan the module and add it to the project. Click the adapter in the project bar on the left and find the "Device Parameters" window to modify the relevant IP parameters.

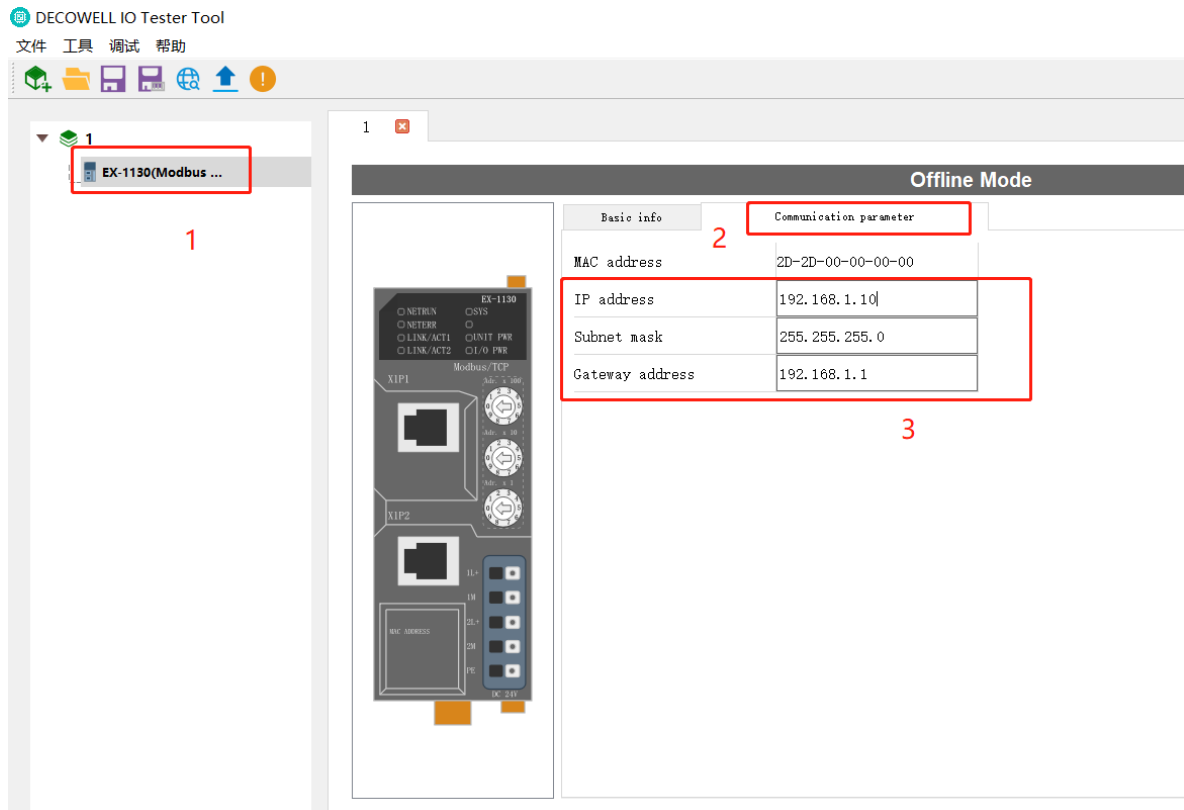

Right-click the device in the project and click "Download Configuration" to download the relevant configuration parameters to the module, which will take effect after a power outage and restart.



IP address setting is completed.

## 1.5.2 Supported function codes

EX-1130 supports standard Modbus TCP function code.

Function code	Function description	Supported IO module types
0x01	Read coil	For example: DO
0x02	Read discrete input	For example: DI
0x03	Read holding register	For example: DO/AO
0x04	Read input register	For example: DI/AI
0x05	Write a single coil	For example: DO
0x06	Write to a single register	For example: DO/AO
0x0F	Write multiple coils	For example: DO
0x10	Write multiple registers	For example: DO/AO

## 1.5.3 I/O module occupied bits or byte length description

digital module		
Model type	Occupied bit length	Remark
8DI	16	The module occupies the lower 8 bits, the upper 8 bits are reserved, and are word aligned.
16DI	16	word alignment
32DI	32	word alignment
8DO	16	The module occupies the lower 8 bits, the upper 8 bits are reserved, and are word aligned.
16DO	16	word alignment
32DO	32	word alignment

Analog module		
Model type	Occupied word length	Remark
4AI	4	word alignment
8AI	8	word alignment
4AO	4	word alignment
8AO	8	word alignment

### 1.5.4I/O Module bits and register address

Function code supported by bit address: 0x01, 0x02, 0x05, 0x0F			
Bit address (decimal)	Read and write properties	Data length	describe
0-8191	RO	Depends on the number of modules	the packaging process data of DI
32768-40959	RW	Depends on the number of modules	The packaging process data of DO
Function code supported by register address: 0x03, 0x04, 0x06, 0x10			
bit address (decimal)	Read and write properties	Data length	describe
0-511	RO	Depends on the number of modules	The packaging data of DI/AI
2048-2559	RW	Depends on the number of modules	The packaging data of DO/AO

## 2. Mechanical installation

### 2.1 Installation dimensions

The installation size information is as shown in the figure below, the unit is (mm).

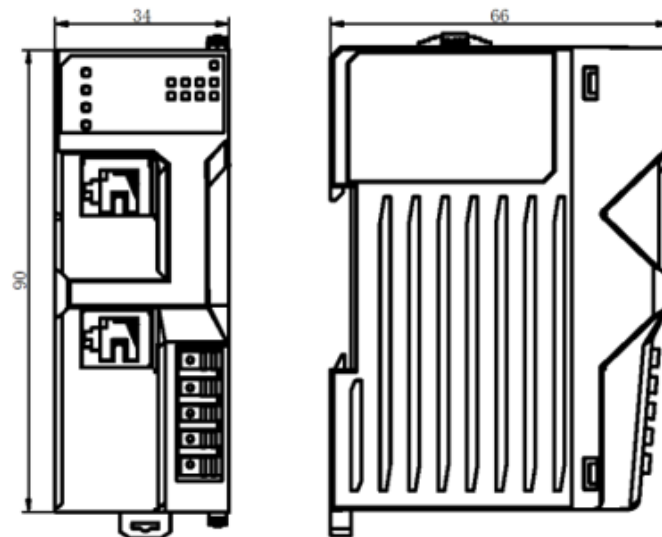

### 2.2 Installation method

#### 2.2.1 Installation between modules

Inter-module assembly via the top and bottom of the module buckle. Install as shown below

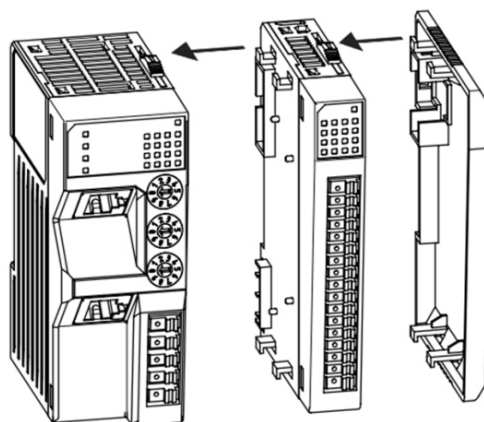

The module is installed using DIN rail. The DIN rail must comply with IEC 60715 standard (35mm wide, 1mm thick).

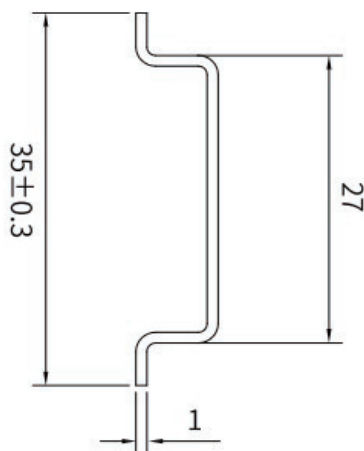

Note: When the module is installed on a DIN35 rail other than those recommended above, the DIN rail lock may not lock properly. Before installing the module, First open the buckle under the module, and then proceed to the next step of installation.

**Notice**

● This product is mounted to DIN rails other than those recommended above (especially DIN rail thickness  $\leq 1.0$  mm), it will cause the DIN rail lock to fail and the product cannot be installed in place, causing the product to not work properly..

## 2.2.2 Installation on guide rail

When installing, align the module with the DIN35 rail and press the module in the direction indicated by the arrow, as shown in the figure below.

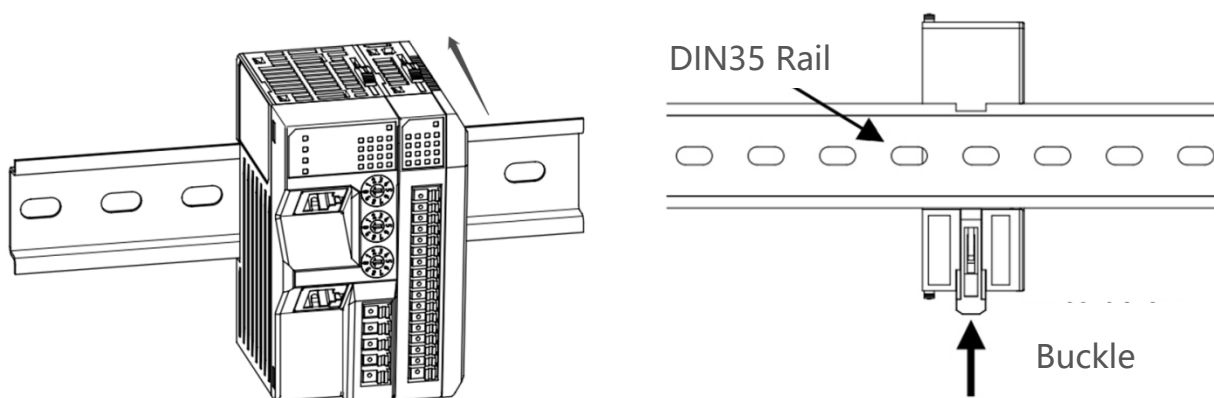

Note: After the module is installed, you need to superior press the top of the lock to ensure it is installed in place.

Disassembly:

Use a flat-blade screwdriver or similar tool to lift the rail latch downwards, and then move the module away from DIN35. Pull out the guide rail.

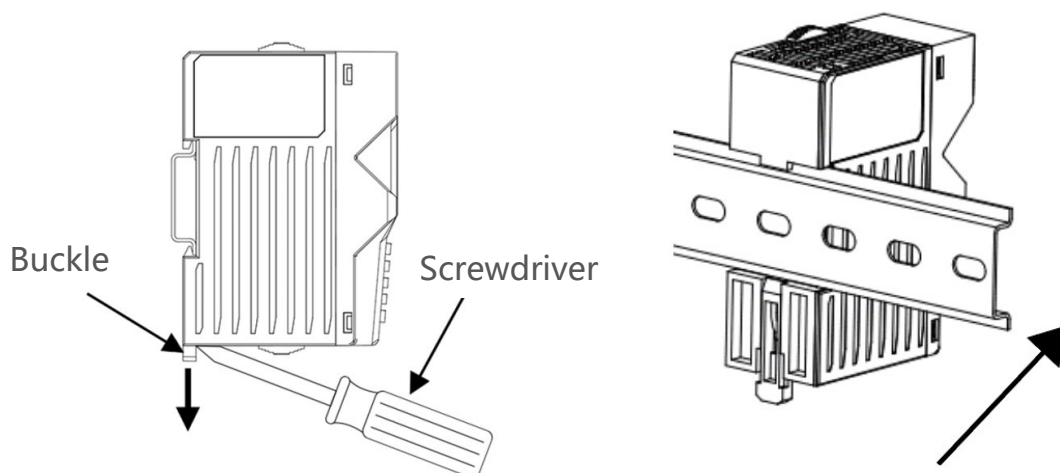

## 3. Electrical Installation

### 3.1 Cable selection

Modbus TCP bus communication uses shielded network cables for network data transmission, without short circuit, misalignment and poor contact. The length of the cable between devices cannot exceed 100m. Exceeding this length will cause signal attenuation and affect normal communication. It is recommended to use the following specifications of network cables:

Name	Function definition
Cable type	Flexible crossover cable, S-FTP, 5line-like
standards met	EIA/TIA568A, EN50173, ISO/IEC11801 EIA/TI A bulletin TSB, EIA/TIA SB40-A&TSB36
Wire cross section	AWG26
Wire type	twisted pair
Line pair	4

Power related cables The wire lug diameters in the following table are for reference only and can be reasonably calculated and adjusted based on actual use.

Name	Adaptable wire diameter	
	National standard/mm <sup>2</sup>	American Standard/AWG
Tubular wire lug	0.75	18
	1.0	18
	1.5	16

The shape and size requirements of riveted terminals are as shown in the figure below:

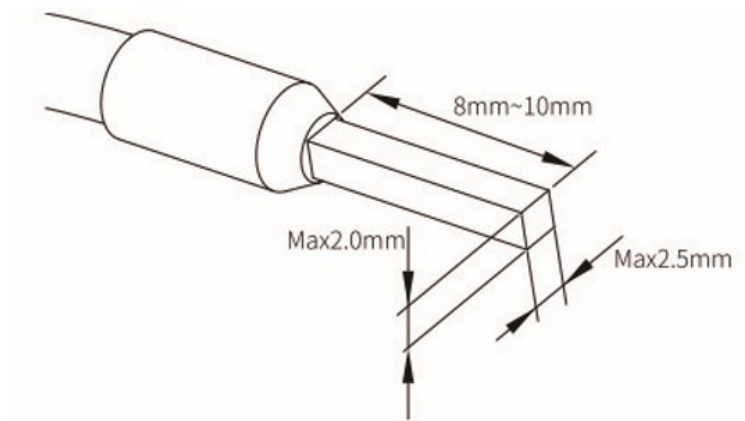

### 3.2 terminal wiring

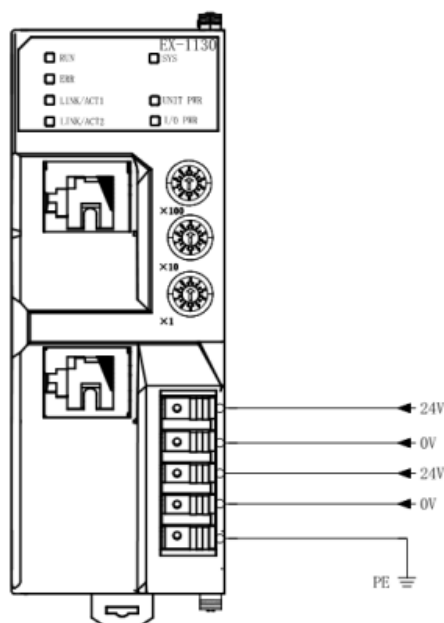

#### Notice

● The ground terminal of the adapter module needs to be directly grounded to prevent interference with the IO module signal.

- The EX series adapter power supply is divided into system power supply and I/O power supply. In order to avoid interference to the system, it is recommended to connect two sets of power cords from the same DC24V power module to the adapter system power supply and I/O power supply respectively.

## 4. Adapter configuration case

### 4.1 Codesys and EX-1130 connections and configuration

#### 4.1.1 Communication connection diagram

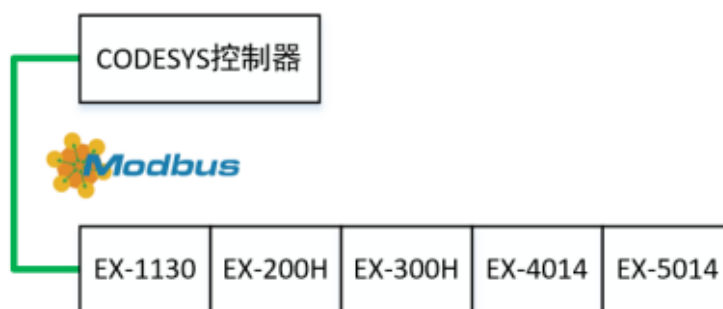

picture4-1-1 Communication connection diagram

#### 4.1.2 Hardware configuration

Hardware configuration table

hardware	quantity	Remark
programming computer	1	Install Codesys3.5sp18
EX-1130	1	Modbus TCP adapter
EX-200H	1	Digital input module
EX-300H	1	Digital output module
EX-4014	1	Analog input module
EX-5014	1	Analog output module

cable	several	
-------	---------	--

### 4.1.3 I/O module address description

When reading or writing registers, the corresponding register address will also change when the module position changes. In the following case, when the number of modules is the same, the corresponding register addresses of the two different module sequences are also different.

Topology 1:

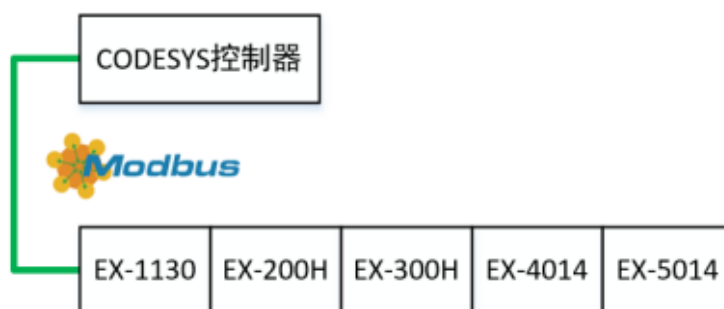

Module model	Read and write coil function code	Address	Read and write register function code	Address
EX-200H	0x02	0-15	0x04	0
EX-300H	0x01 0x05 0x0F	32768-32783	0x03 0x06 0x10	2048
EX-4014	--	--	0x04	1-4
EX-5014	--	--	0x03 0x06 0x10	2049-2052

Topology 2:

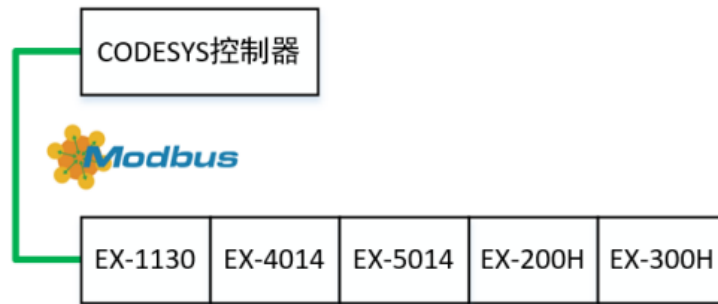

Module model	Read and write coil function code	Address	Read and write register function code	Address
EX-4014	--	--	0x04	0-3
EX-5014	--	--	0x03 0x06 0x10	2048-2051
EX-200H	0x02	0-15	0x04	4
EX-300H	0x01 0x05 0x0F	32768-32783	0x03 0x06 0x10	2052

#### 4.1.4 New project and configuration

After creating a new project, configure Modbus TCP in the project tree, and configure parameters such as the Modbus TCP slave IP address (The IP address of the EX-1130 adapter used is 192.168.1.10 in this case). As shown in the picture 4-1-2.



Picture 4-1-2 New project and configuration

Configure Modbus TCP slave channel. As shown in the picture 4-1-3 shown.

名称	访问类型	触发器	读偏移	长度	错误处理	写偏移	长度	注释
0 读取DI	Read Discrete Inputs (函数代码 02)	循环, t#100ms	16#0000	16	Keep last value			
1 读取DO	Read Coils (函数代码 01)	循环, t#100ms	16#8000	16	Keep last value			
2 写入DO	Write Multiple Coils (函数代码 15)	循环, t#100ms				16#8000	16	
3 读取AI	Read Input Registers (函数代码 04)	循环, t#100ms	16#0001	4	Keep last value			
4 写入AO	Write Multiple Registers (函数代码 16)	循环, t#100ms				16#0801	4	
5 读取AO	Read Holding Registers (函数代码 03)	循环, t#100ms	16#0801	4	Keep last value			

Picture 4-1-3 Slave channel configuration

Modbus TCP slave I/O mapping. As shown in Figure 4-1-4 shown.

变量	映射	通道	地址	类型	当前值	预备值	单元	描述
		读取DI	%IB0	ARRAY [0..1] OF BYTE				Read Discrete Inputs
		读取DI[0]	%IB0	BYTE	3			Read Discrete Inputs
		读取DI[1]	%IB1	BYTE	0			Read Discrete Inputs
		读取DO	%IB2	ARRAY [0..1] OF BYTE				Read Coils
		读取DO[0]	%IB2	BYTE	255			Read Coils
		读取DO[1]	%IB3	BYTE	255			Read Coils
		写入DO	%QB0	ARRAY [0..1] OF BYTE				Write Multiple Coils
		写入DO[0]	%QB0	BYTE	255			Write Multiple Coils
		写入DO[1]	%QB1	BYTE	255			Write Multiple Coils
		读取AI	%IW2	ARRAY [0..3] OF WORD				Read Input Registers
		读取AI[0]	%IW2	WORD	1023			0x0001
		读取AI[1]	%IW3	WORD	2			0x0002
		读取AI[2]	%IW4	WORD	0			0x0003
		读取AI[3]	%IW5	WORD	0			0x0004
		写入AO	%QW1	ARRAY [0..3] OF WORD				Write Multiple Registers
		写入AO[0]	%QW1	WORD	1024			0x0801
		写入AO[1]	%QW2	WORD	2048			0x0802
		写入AO[2]	%QW3	WORD	4095			0x0803
		写入AO[3]	%QW4	WORD	1000			0x0804
		读取AO	%IW6	ARRAY [0..3] OF WORD				Read Holding Registers
		读取AO[0]	%IW6	WORD	1024			0x0801
		读取AO[1]	%IW7	WORD	2048			0x0802
		读取AO[2]	%IW8	WORD	4095			0x0803
		读取AO[3]	%IW9	WORD	1000			0x0804

Picture 4-1-4 Slave I/O mapping

Download the program after reaching the controller and running, you can control and monitor its status.

#### 4.1.5 Bus exception output settings

It can be configured to output the IO module status when the bus communication is abnormal (the output is turned off or the last value of the program is retained, the default is output off).

Register address	Read and write properties	type of data	Function description
4405	RW	WORD	Output behavior in case of fieldbus errors 0x0000=All outputs are turned off/cleared 0x0002=keep last value

## 4.2 Siemens S7-1500 with EX-1130 connections and configuration

## 4.2.1 Communication connection diagram

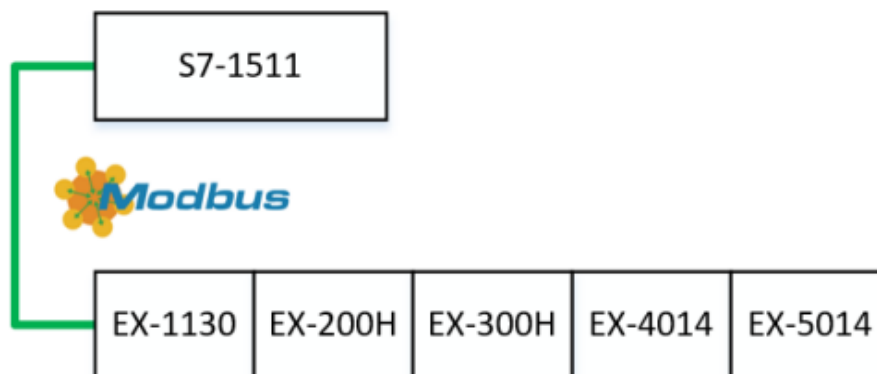

Picture 4-2-1 Communication connection diagram

## 4.2.2 Hardware configuration

Hardware configuration table

Hardware	Quantity	Remark
programming computer	1	Install Machine Expert V2.0
S7-1511	1	Siemens S7-1500PLC
EX-1130	1	Modbus TCPadapter
EX-200H	1	Digital input module
EX-300H	1	Digital output module
EX-4014	1	Analog input module
EX-5014	1	Analog output module
cable	several	

## 4.2. 3I/0 module address description

When reading or writing registers, the corresponding register address will also change when the module position changes. In the following case, when the number of modules is the same, the corresponding register addresses of the two different module sequences are also different.

## Topology 1:

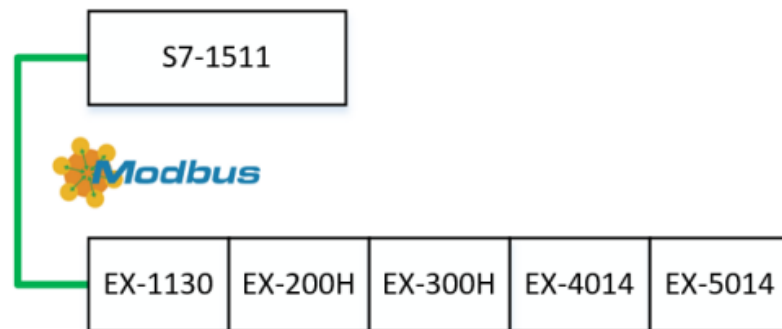

Module model	Read and write coil function code	Address	Read and write register function code	Address
EX-200H	0x02	0-15	0x04	0
EX-300H	0x01 0x05 0x0F	32768-32783	0x03 0x06 0x10	2048
EX-4014	--	--	0x04	1-4
EX-5014	--	--	0x03 0x06 0x10	2049-2052

## Topology 2:

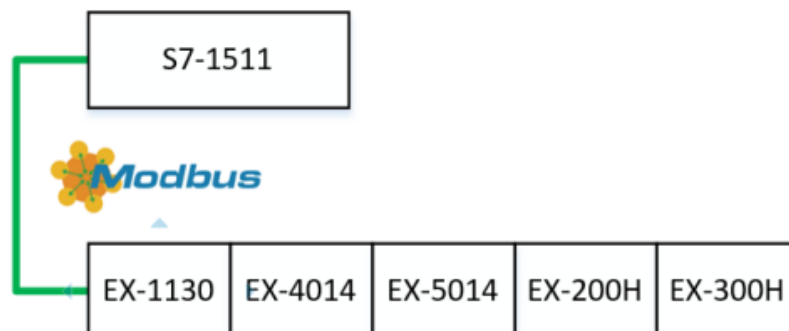

Module model	Read and write coil function code	Address	Read and write register function code	Address
EX-4014	--	--	0x04	0-3
EX-5014	--	--	0x03 0x06 0x10	2048-2051
EX-200H	0x02	0-15	0x04	4
EX-300H	0x01 0x05 0x0F	32768-32783	0x03 0x06 0x10	2052

#### 4.2.5 New project and equipment configuration

Open TIA Portal programming software, after creating a new project, create a DB data block, which is used to point to the pointer to the connection description structure, and configure EX-1130 parameters such as IP address and PLC hardware port number.

名称	数据类型	起始值	保持	从 HMI/OPC...	从 H...	在 HMI...	设定值	监控	注释
Static	TCON_IP_v4								
InterfaceId	HW_ANY	64							HWIdentifier of IE-interface submodule
ID	CONN_OUC	1							connection reference / identifier
ConnectionType	Byte	16#0B							type of connection: 11=TCP/IP, 19=UDP (17=TCP)
ActiveEstablished	Bool	TRUE							active/passive connection establishment
RemoteAddress	IP_V4								remote IP address (IPv4)
ADDR	Array[1..4] of Byte								IPv4 address
ADDR[1]	Byte	192							IPv4 address
ADDR[2]	Byte	168							IPv4 address
ADDR[3]	Byte	1							IPv4 address
ADDR[4]	Byte	10							IPv4 address
RemotePort	UInt	502							remote UDP/TCP port number
LocalPort	UInt	0							local UDP/TCP port number

Add the Modbus\_Clint function block to OBO and configure its pin parameters:

- ① Read DI status and read EX-200H status values of all channels. The first channel has received the signal of EX-200H in this case.

Line	Description	Address	Data Type	Status
34	"Modbus TCP通讯参数" 写DO[13]	%DB3.DBX15.5	布尔型	FALSE
35	"Modbus TCP通讯参数" 写DO[14]	%DB3.DBX15.6	布尔型	FALSE
36	"Modbus TCP通讯参数" 写DO[15]	%DB3.DBX15.7	布尔型	FALSE
37	#读取DI状态			
38	"Modbus TCP通讯参数" 发送请求[2]	%DB3.DBX0.2	布尔型	TRUE
39	"Modbus TCP通讯参数" 读取DI[0]	%DB3.DBX12.0	布尔型	TRUE
40	"Modbus TCP通讯参数" 读取DI[1]	%DB3.DBX12.1	布尔型	FALSE
41	"Modbus TCP通讯参数" 读取DI[2]	%DB3.DBX12.2	布尔型	FALSE
42	"Modbus TCP通讯参数" 读取DI[3]	%DB3.DBX12.3	布尔型	FALSE
43	"Modbus TCP通讯参数" 读取DI[4]	%DB3.DBX12.4	布尔型	FALSE
44	"Modbus TCP通讯参数" 读取DI[5]	%DB3.DBX12.5	布尔型	FALSE
45	"Modbus TCP通讯参数" 读取DI[6]	%DB3.DBX12.6	布尔型	FALSE
46	"Modbus TCP通讯参数" 读取DI[7]	%DB3.DBX12.7	布尔型	FALSE
47	"Modbus TCP通讯参数" 读取DI[8]	%DB3.DBX13.0	布尔型	FALSE
48	"Modbus TCP通讯参数" 读取DI[9]	%DB3.DBX13.1	布尔型	FALSE
49	"Modbus TCP通讯参数" 读取DI[10]	%DB3.DBX13.2	布尔型	FALSE
50	"Modbus TCP通讯参数" 读取DI[11]	%DB3.DBX13.3	布尔型	FALSE
51	"Modbus TCP通讯参数" 读取DI[12]	%DB3.DBX13.4	布尔型	FALSE
52	"Modbus TCP通讯参数" 读取DI[13]	%DB3.DBX13.5	布尔型	FALSE
53	"Modbus TCP通讯参数" 读取DI[14]	%DB3.DBX13.6	布尔型	FALSE
54	"Modbus TCP通讯参数" 读取DI[15]	%DB3.DBX13.7	布尔型	FALSE
55	#读取AO状态			
56	"Modbus TCP通讯参数" 发送请求[3]	%DB3.DBX0.3	布尔型	FALSE
57	"Modbus TCP通讯参数" 读取AO[0]	%DB3.DBW16	十六进制	16#0100
58	"Modbus TCP通讯参数" 读取AO[1]	%DB3.DBW18	十六进制	16#0200
59	"Modbus TCP通讯参数" 读取AO[2]	%DB3.DBW20	十六进制	16#0300
60	"Modbus TCP通讯参数" 读取AO[3]	%DB3.DBW22	十六进制	16#0400

② Write values to all DO channels, channel 0-3 is set to TRUE of EX-300H in the case.

Line	Description	Address	Data Type	Status
17	"Modbus TCP通讯参数" 读取DO[14]	%DB3.DBX11.6	布尔型	FALSE
18	"Modbus TCP通讯参数" 读取DO[15]	%DB3.DBX11.7	布尔型	FALSE
19	#写入DO			
20	"Modbus TCP通讯参数" 发送请求[1]	%DB3.DBX0.1	布尔型	TRUE
21	"Modbus TCP通讯参数" 写DO[0]	%DB3.DBX14.0	布尔型	TRUE
22	"Modbus TCP通讯参数" 写DO[1]	%DB3.DBX14.1	布尔型	TRUE
23	"Modbus TCP通讯参数" 写DO[2]	%DB3.DBX14.2	布尔型	TRUE
24	"Modbus TCP通讯参数" 写DO[3]	%DB3.DBX14.3	布尔型	TRUE
25	"Modbus TCP通讯参数" 写DO[4]	%DB3.DBX14.4	布尔型	FALSE
26	"Modbus TCP通讯参数" 写DO[5]	%DB3.DBX14.5	布尔型	FALSE
27	"Modbus TCP通讯参数" 写DO[6]	%DB3.DBX14.6	布尔型	FALSE
28	"Modbus TCP通讯参数" 写DO[7]	%DB3.DBX14.7	布尔型	FALSE
29	"Modbus TCP通讯参数" 写DO[8]	%DB3.DBX15.0	布尔型	FALSE
30	"Modbus TCP通讯参数" 写DO[9]	%DB3.DBX15.1	布尔型	FALSE
31	"Modbus TCP通讯参数" 写DO[10]	%DB3.DBX15.2	布尔型	FALSE
32	"Modbus TCP通讯参数" 写DO[11]	%DB3.DBX15.3	布尔型	FALSE
33	"Modbus TCP通讯参数" 写DO[12]	%DB3.DBX15.4	布尔型	FALSE
34	"Modbus TCP通讯参数" 写DO[13]	%DB3.DBX15.5	布尔型	FALSE
35	"Modbus TCP通讯参数" 写DO[14]	%DB3.DBX15.6	布尔型	FALSE
36	"Modbus TCP通讯参数" 写DO[15]	%DB3.DBX15.7	布尔型	FALSE
37	#读取DI状态			
38	"Modbus TCP通讯参数" 发送请求[2]	%DB3.DBX0.2	布尔型	FALSE
39	"Modbus TCP通讯参数" 读取DI[0]	%DB3.DBX12.0	布尔型	TRUE
40	"Modbus TCP通讯参数" 读取DI[1]	%DB3.DBX12.1	布尔型	FALSE
41	"Modbus TCP通讯参数" 读取DI[2]	%DB3.DBX12.2	布尔型	FALSE

③ Read the DO channel status and read the 16-channel status of EX-300H in the case.

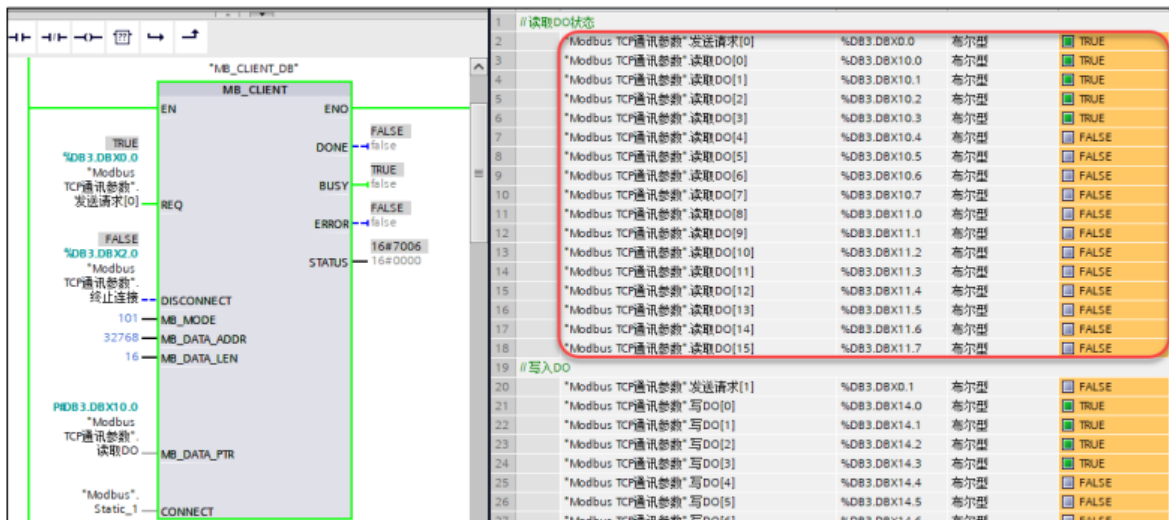

④ Read the AI value. In the case, the first channel of the EX-4014 module has been connected to the external signal.

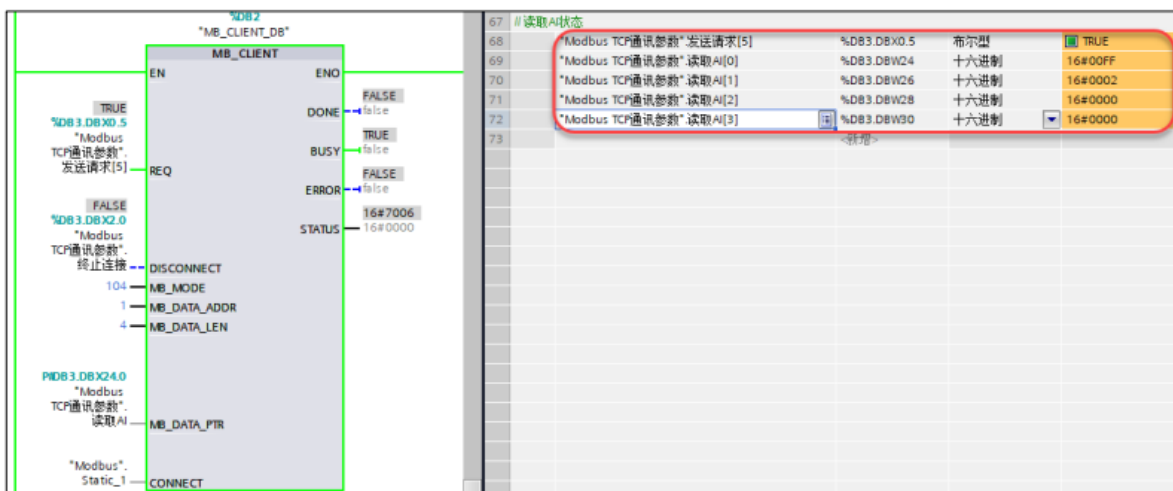

⑤ Write the AO value to the 4 channels in the EX-5014 in the case.

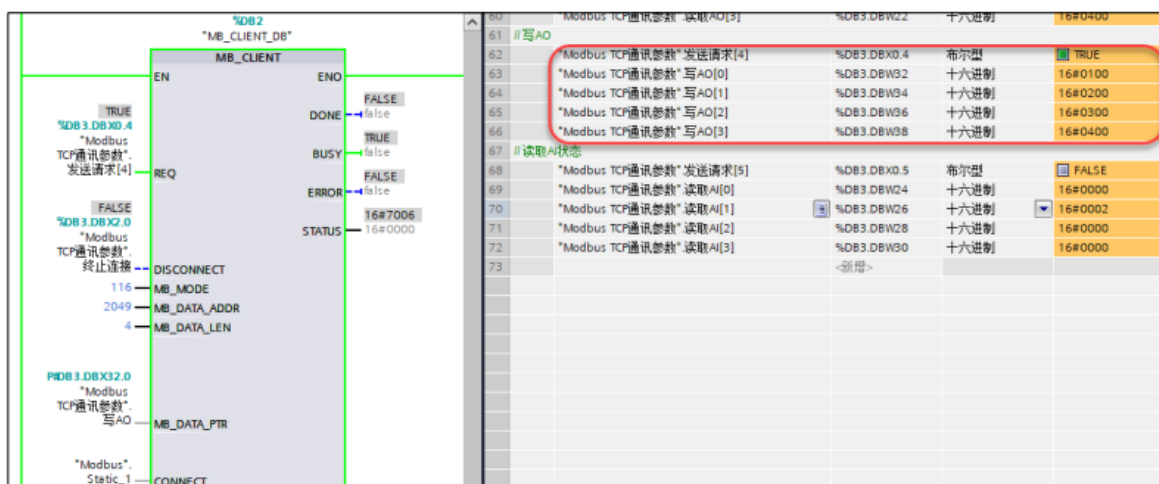

⑥ Read the AO value read the 4 channel values of EX-5014 in the case.

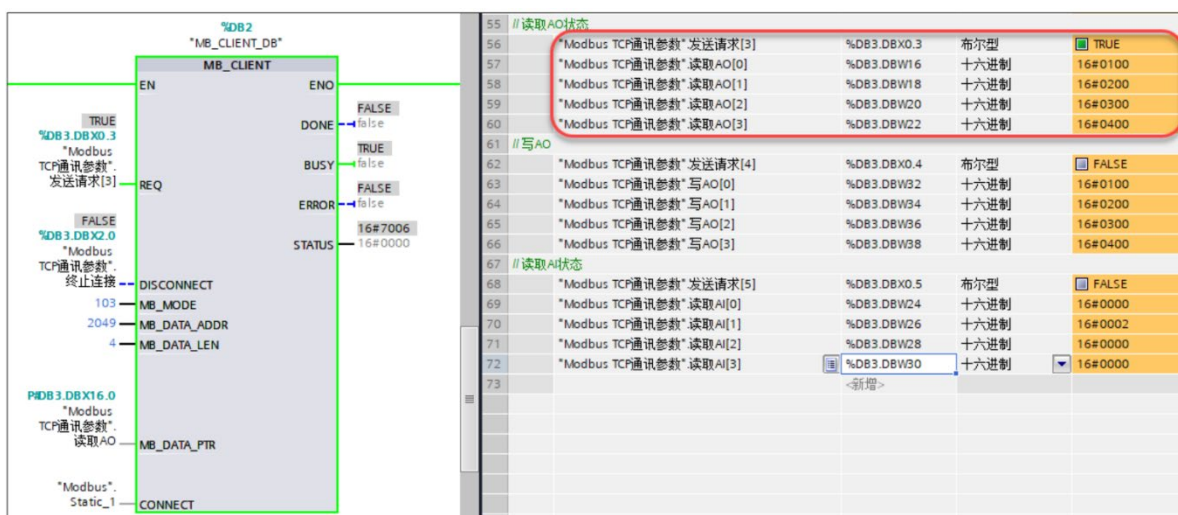

### 4.2.6Bus exception output settings

It can be configured to output the IO module status when the bus communication is abnormal (the output is turned off or the last value of the program is retained, the default is output off).

Register address	Read and write properties	Type of data	Function description
4405	RW	WORD	Output behavior in case of fieldbus errors

			0x0000=All outputs are turned off/cleared 0x0002=keep last value
--	--	--	--

## 5. Product usage FAQ

### ■ Module usage issues

**Q:**Do both sets of EX-1130 adapter power connections have to be connected?

**A:**There are two sets power supplies of EX-1130 that must be wired:

1L+/1M is the system power supply, which supplies power for module communication and indicator lights;

2L+/2M is the I/O power supply, which provides output voltage to the digital output module.

**Q:**EX-1130 equipped with digital quantity/analog.Can the input module configure the input filter time?

**A:**Yes, through the official parameter configuration software of Decowell IOTesterTool can be set.

**Q:**What types of IO modules can the EX-1130 be equipped with?

**A:**Digital quantity, analog quantity, thermocouple, thermal resistance, function, communication module.

### ■ Network communication problems

**Q:**Does the EX-1130 support redundancy or ring networking?

**A:**not support.

**Q:**What should you pay attention to when communicating directly with EX-1130 and HMI?

**A:**The communication configuration address between HMI and EX-1130 will have an offset of 1. For example, the DI starting address is 0. When HMI needs to access, the address should be set to 1 (the same DO/AI/AO address also has an offset of 1).

**Q:**Does the EX-1130 have switch function as it is designed with dual network ports?

**A:**Has switch function.

## 6. Appendix

EX-1130 address table

Address	Read and write properties	Type of data	Describe	Remark
4096-4107	RO	Byte	adapter identifier	
4108	RO	Word	adapter status	
4109	RO	Word	running counter	16-bit counter, 1ms increment
4110	RO	Word	Port connection status	Bit 0: Port 1 connection status (1-connected; 0-disconnected) Bit 1: Port 2 connection status (1-connected; 0-disconnected)
4112	RO	Word	Process image bit length of the output module	
4113	RO	Word	loseenterProcess image bit length of module	
4119	RO	Word	Register map version number	
4120-4121	RO	Byte	Collective diagnostic message of the I/O modules (1 bit per IO module)	
4128-4135	RO	Byte	Adapter serial number	
4136-4139	RO	Byte	Module status (2 bits for each I/O module)	

			00 = Module is correct; 01 = Module error; 10 = incorrect module; 11 = Module not inserted	
4144	RO	Word	Modbus watchdog, current time (x*10ms) 0 = Watchdog has expired; 0xFFFF = watchdog disabled	
4384	RW	Word	Modbus watchdog, predefined time (x*10ms), default value=0ms (no watchdog activated)	
4385	RW	Word	Data exchange Modbus watchdog, reset register Bit 0 = 1 Watchdog resets at predefined time; Bit 8 = 1 Restart after watchdog expiration	
4401	RW	Word	Modbus connection timeout (seconds) Default=30 (0=disabled)	
4405	RW	Word	Fieldbus error output behavior 0x0000 =All outputs are off 0x0002 =Keep last value	
10238	RO	Word	Number of entries in the current module list	

10752-10815	RO	DWord	Current module list Maximum 32 modules per station * 2 registers per module	Each module ID occupies 4 bytes (i.e. 2 registers)
-------------	----	-------	--	--

本手册如有参数更新, 恕不另行通知。



# 南京德克威尔自动化有限公司

Nanjing Decowell Automation Co., Ltd.

全国服务热线

## 400-0969016

地址: 南京市浦口区兰新路19号瑞创智造园13号楼

网址: [www.wellinkio.com](http://www.wellinkio.com)

邮箱: [sales@wellinkio.com](mailto:sales@wellinkio.com)

