

RB系列I/O模块

用户手册

德克威尔 · 工业智造可靠伙伴



网址: www.wellinkio.com

邮箱: sales@wellinkio.com

地址: 南京市浦口区兰新路19号瑞创智造园13号楼

Preface

■ Brief introduction

Thank you for purchasing the Decowell RB Series card-type I/O modules!

RB Series card-type I/O modules is a distributed extension module developed by DECOWELL. This series module consists of adapter, I/O module, power module and terminal module. Adapters can support a variety of communication buses, Such as PROFINET、EtherCAT、CC-Link、Modbus TCP etc. I/O module can be divided into digital input module, digital output module, analog input module, analog output module and function module, users can be matched according to the actual application.

Digital input module and digital output module are commonly used I/O modules of RB series.

This manual mainly describes the specifications, features and usage of the module, please read it carefully before use, so that you can use the product more clearly and safely.

CONTENTS

Preface.....	2
Safety precautions.....	5
1.Product information.....	8
1.1 Digital input module.....	8
1.1.1 Product model information.....	8
1.1.2 Technical specification.....	9
1.2 Digital output module.....	11
1.2.1 Product model information.....	11
1.2.2 Technical specification.....	12
1.3 Environmental specification.....	15
1.4 PWR/STA Indicator description.....	16
2.Mechanical installation.....	17
2.1 Installation dimensions.....	17
2.2 Installation method.....	18
2.2.1 Installation between modules.....	18

2.2.2 Installation on the guide rail.....	19
3. Electrical installation.....	20
3.1 Cable selection.....	20
3.2 Terminal wiring.....	21
3.2.1 Digital input module wiring diagram.....	21
3.2.2 Digital output module wiring diagram.....	25
4. Module configuration information.....	30
4.1 Module input and output bytes.....	30
4.2 The DO module supports single-channel alternative value configuration...31	
4.2 The DI module supports filtering configuration.....	32

Safety precautions

■ Safety statement

01. When installing, operating, and maintaining the product, read and follow these safety precautions.

02. To ensure the safety of the human body and the device, follow the labels on the product and all the safety precautions described in this document when installing, operating, and maintaining the product.

03. The “Tips”, “attention”, “warning” and “danger” in this manual do not represent all safety precautions to be followed, but only serve as a supplement to all safety precautions.

04. This product should be used in an environment that meets the requirements of the design specifications, otherwise it may cause failure, and the abnormal function or component damage caused by non-compliance with the relevant regulations are not within the scope of product quality assurance.

05. Due to the illegal operation of products caused by personal safety accidents, property damage, etc., Decowell does not assume any legal responsibility.

■ Security Level Definition

Tips

The mark indicates “necessary additions or clarifications to the description of the operation” .

Notice

The mark “Hazard caused by failure to perform as required, which could result in mild or moderate injury to human body and damage to equipment” .



Warning

The mark indicates that “personal injury or death may result from hazards caused by failure to perform as required”.

■ During control system design ⚡ Warning

01. In the application, it is necessary to design a safety circuit to ensure that the control system can still work safely when the external power supply fails or the expansion module fails.

02. When the output circuit exceeds the rated load current or the load short circuit leads to long-term overcurrent, the module may smoke or catch fire, and safety devices such as fuses or circuit breakers should be set outside.。

■ During control system design ⚠ Notices

01. The external circuit of the expansion module must be equipped with an emergency brake circuit, a protection circuit, an interlock circuit for forward and reverse operation and a position upper limit and lower limit interlock switch to prevent machine damage;

02. In order to ensure the safe operation of the equipment, please design external protection circuits and safety mechanisms for output signals related to major accidents;

03. When the relay, transistor and other output units of the expansion module are damaged, the output can not be controlled to ON or OFF state;

04. The expansion module is designed to be used in an indoor electrical environment with an overvoltage level II. The power system level of the expansion module should have a lightning protection device to ensure that the lightning overvoltage is not applied to the power input, signal input, and control output ports of the expansion module to avoid device damage.

1. Product information

1.1 Digital input module

1.1.1 Product model information

Model number	Specification description	Order number
RB-2018	8 channels digital input, input signal is low level NPN Support 2-wire sensor	18-02-05
RB-2118	8 channels digital input, input signal is low level PNP Support 2-wire sensor	18-02-06
RB-200H	16 channels digital input, input signal is low level NPN	18-02-02
RB-210H	16 channels digital input, input signal is high level PNP	18-02-04

1.1.2 Technical specification

● RB-2018/RB-2118 Input module parameter

Basic parameter		
Overall dimension	100mm×77mm×12mm	
Class of protection	IP20	
Wiring specification	0.2~1.5mm ²	
Connection mode	screw-free	
weight	70g	
Technical parameter		
Model number	RB-2018	RB-2118
Product name	Digital input module	
Signal type	NPN	PNP
Power dissipation	57mA	62mA
Input channel number	8	
Input rated voltage	NPN: DC 0V (±3%)	PNP: DC 24V (±25%)
Enter the logic 1 signal	-3~5V	11~30V
Input logical 0 signal	11~30V	-3~5V
Enter response time from OFF to ON	5us	5us
Enter response time ON to OFF	3us	3us
Maximum response time when the time management polling mode is used	1ms	
Sensor power supply	24V/150mA (MAX)	24V/150mA (MAX)
Filter parameter	The value can be 0.5 to 10ms. The default value is 3ms	
Isolated withstand voltage	500V	
Isolation mode	Optocoupler isolation	

RB series I/O module

● RB-200H/RB-210H Input module parameter

Basic parameter		
Overall dimension	100mm×77mm×12mm	
Class of protection	IP20	
Wiring specification	0.2~1.5mm ²	
Connection mode	screw-free	
weight	70g	
Technical parameter		
Model number	RB-200H	RB-210H
Product name	Digital input module	
Signal type	NPN	PNP
Power dissipation	57mA	62mA
Input channel number	16	
Input rated voltage	NPN: DC 0V (±3%)	PNP: DC 24V (±25%)
Enter the logic 1 signal	-3~5V	11~30V
Input logical 0 signal	11~30V	-3~5V
Enter response time from OFF to ON	5us	5us
Enter response time ON to OFF	3us	3us
Maximum response time when the time management polling mode is used	1ms	
Filter parameter	The value can be 0.5 to 10ms. The default value is 3ms	
Isolated withstand voltage	500V	
Isolation mode	Optocoupler isolation	

1.2 Digital output module

1.2.1 Product model information

Model number	Specification description	Order number
RB-3018	8 digital output, output signal is low level (NPN) Support two-wire sensor	18-03-05
RB-3118	8 channels digital output, output signal is high level (PNP) Support two-wire sensor	18-03-06
RB-300H	16 channels digital output, output signal is low level (NPN)	18-03-02
RB-310H	16 channels digital output, output signal is high level (PNP)	18-03-04
RB-3204	4 point relay output	18-04-01

RB series I/O module

1.2.2 Technical specification

● RB-3018/RB-31180 output module parameter

Basic parameter		
Overall dimension	100mm×77mm×12mm	
Class of protection	IP20	
Wiring specification	0.2~1.5mm ²	
Connection mode	screw-free	
weight	70g	
Technical parameter		
Model number	RB-3018	RB-3118
Product name	Digital output module	
Signal type	NPN	PNP
Power dissipation	88mA	113mA
Output channel number	8	
Output rated voltage	NPN: DC 0V (±3%)	PNP: DC 24V (±25%)
Driving ability	Single channel Max. 0.5A/ Max. 2A load current per 8 consecutive channels	
The output response time is OFF to ON	5us	15us
The output response time is ON to OFF	3us	18us
Maximum response time when the time management polling mode is used	1ms	
Load type	Resistive load, inductive load, lamp load	
Isolated withstand voltage	500V	
Isolation mode	Optocoupler isolation	

● RB-3204 Relay output module parameters

Basic parameter	
Overall dimension	100mm×77mm×12mm
Class of protection	IP20
Wiring specification	0.2~1.5mm ²
Connection mode	screw-free
weight	70g
Technical parameter	
Model number	RB-3204
Product name	Relay output module
Signal type	Relay
Power dissipation	20mA
Output channel number	4
Driving ability	5A 30VDC/5A 250VAC
Minimum allowable load	5V DC/1mA
Maximum switching current	5A
Maximum switching voltage	30VDC/250VAC
Maximum switching power	250VAC/150W
Load type	Resistive load, inductive load, lamp load
Isolated withstand voltage	500V
Isolation mode	Optocoupler isolation

● RB-300H/RB-310H Output module parameter

Basic parameter		
Overall dimension	100mm×77mm×12mm	
Class of protection	IP20	
Wiring specification	0.2~1.5mm ²	
Connection mode	screw-free	
weight	70g	
Technical parameter		
Model number	RB-300H	RB-310H
Product name	Digital output module	
Signal type	NPN	PNP
Power dissipation	88mA	110mA
Output channel number	16	
Output rated voltage	NPN: DC 0V (±3%)	PNP: DC 24V (±25%)
Driving ability	Single channel Max. 0.5A/ Max. 2A load current per 8 consecutive channels	
The output response time is OFF to ON	5us	15us
The output response time is ON to OFF	3us	18us
Maximum response time when the time management polling mode is used	1ms	
Load type	Resistive load, inductive load, lamp load	
Isolated withstand voltage	500V	
Isolation mode	Optocoupler isolation	

1.3 Environmental specification

Environmental parameter	
Operating temperature	-20~55°C
Working humidity	95% non-condensing
atmosphere	≥ 795 hPa (altitude ≤ 2000 m) as per IEC 61131-2
Storage temperature	-40~+70°C
Overvoltage class	I

1.4 PWR/STA Indicator description

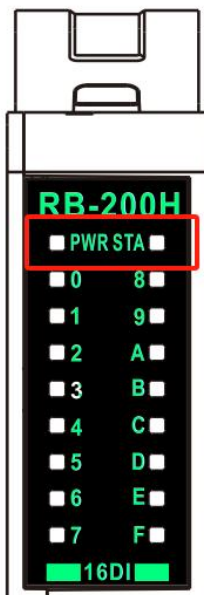

LED	status	description
STA	Blinking red (5HZ)	Module self-test exception (internal failure)
	Red light always on	The module does not communicate with the adapter, and the configuration information fails to be loaded
	Green light always on	Module working properly
	Blinking red at slow intervals (1HZ)	Module hardware exception
PWR	Green light always on	Internal power supply normal (5V system side)
	Green light off	No power supply or abnormal power supply (5V system)

2. Mechanical installation

2.1 Mounting dimension

The installation dimensions are shown in the following figure (unit: mm).



Notice

- The dimensions below apply to digital input/output modules

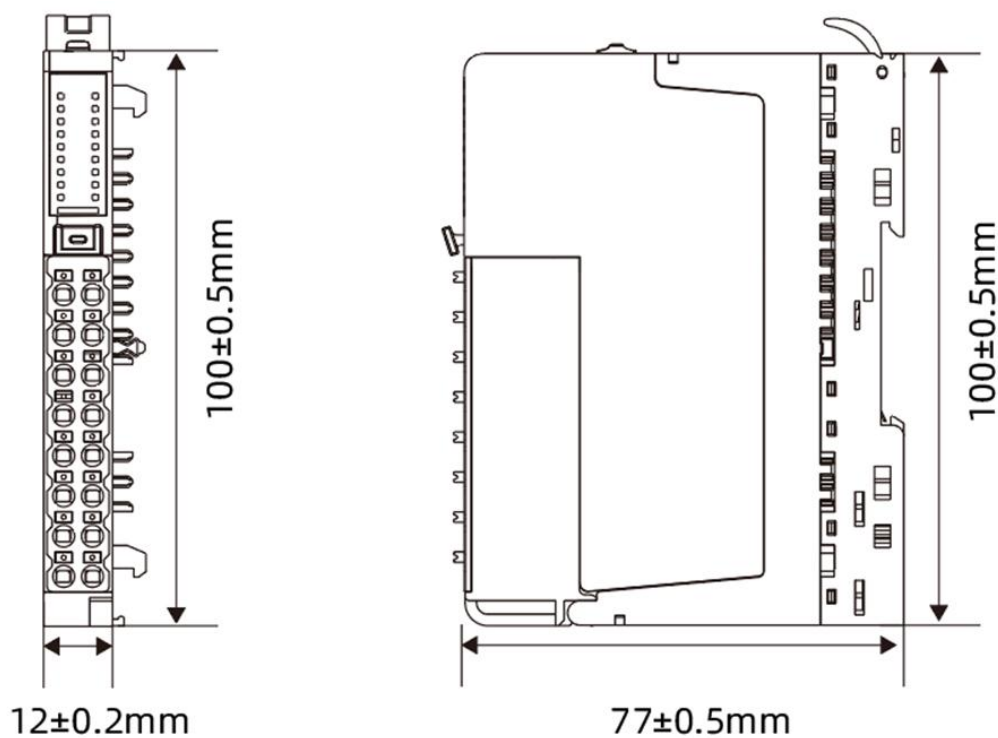

2.2 Installation method

2.2.1 Intermodule installation

The intermodule assembly is installed through the locking joystick on the top of the module, as shown below

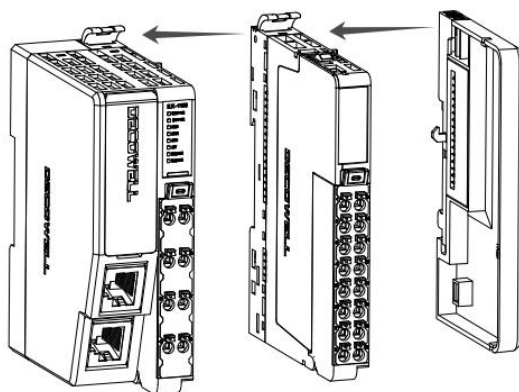

The modules are mounted on DIN rails, which comply with IEC 60715 standards (35mm wide, 1mm thick), dimensional information.

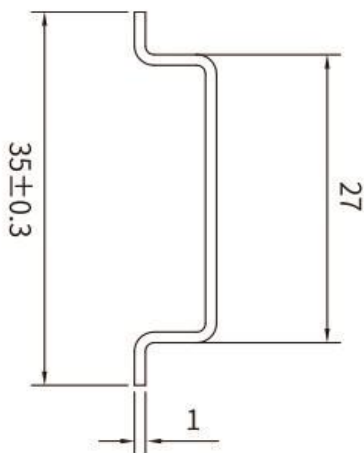

Note: The DIN rail latch may not lock properly when the module is installed on a rail other than the recommended DIN35 rail. Before installing the module, open the lock lever on the top of the module, and then proceed to the next step.

 Notice

- When the product is installed on a DIN guide that is not recommended above (especially when the thickness of the DIN guide is less than 1.0mm), the DIN guide lock will fail, and the product will not be installed in place, which will cause the product to not work properly.

2.2.2 Mounting on rail

During installation, align the module with the DIN35 guide rail and press the module in the direction indicated by the arrow, as shown in the figure below.

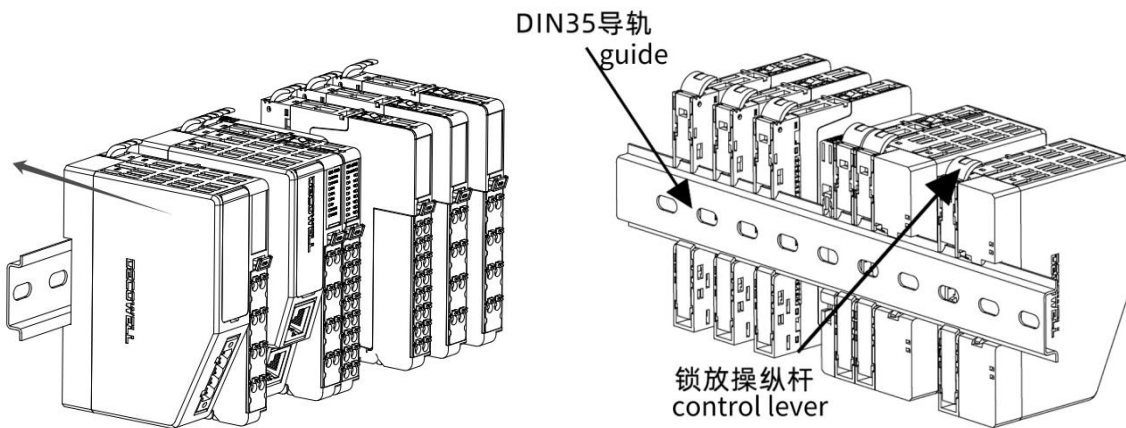

Note: After the module is installed, press down the locking lever to fix the module to the guide rail to ensure that the module is installed in place.

disassembly:

Use your hand to push the lock up on the joystick and pull the module away from the DIN35 guide rail.

3. Electrical installation

3.1 Cable selection

For power cables, the ear diameters in the following table are for reference only. You can calculate and adjust them based on actual use

name	Fitting diameter	
	National standard/mm ²	American standard/AWG
Tubular lug	0.75	18
	1.0	18
	1.5	16

The shape and size requirements of riveting terminals are shown in the following figure:

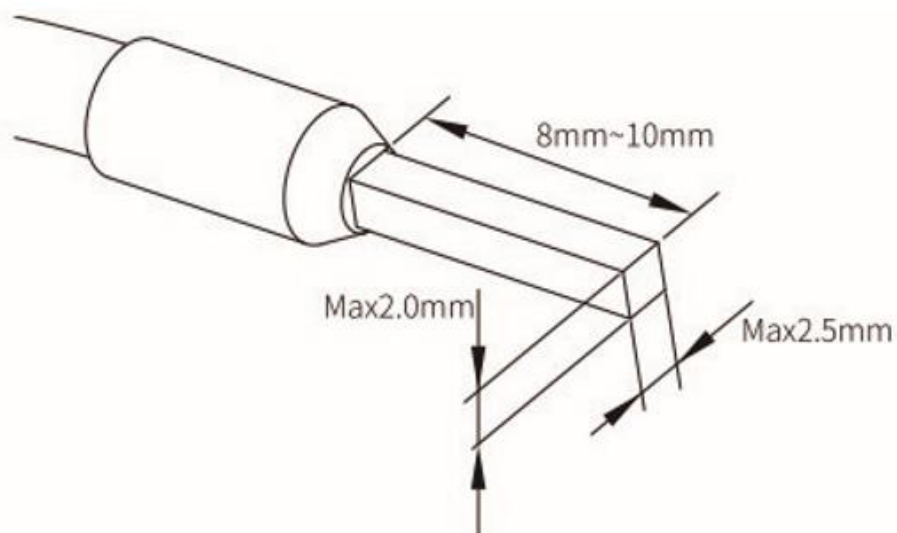

3.2 Terminal connection

 **Notice**

● RB series adapter power supply is divided into system power supply and I/O power supply. To avoid interference to the system, it is recommended to connect two sets of power cables from the same DC24V power module to the adapter system power supply and I/O power supply respectively.

● To ensure the normal use of the module, check whether the I/O power supply on the adapter is properly connected before use.

3.2.1 Digital input module wiring diagram

 **Notice**

● The RB-200H is an NPN type with an input signal of 0V.

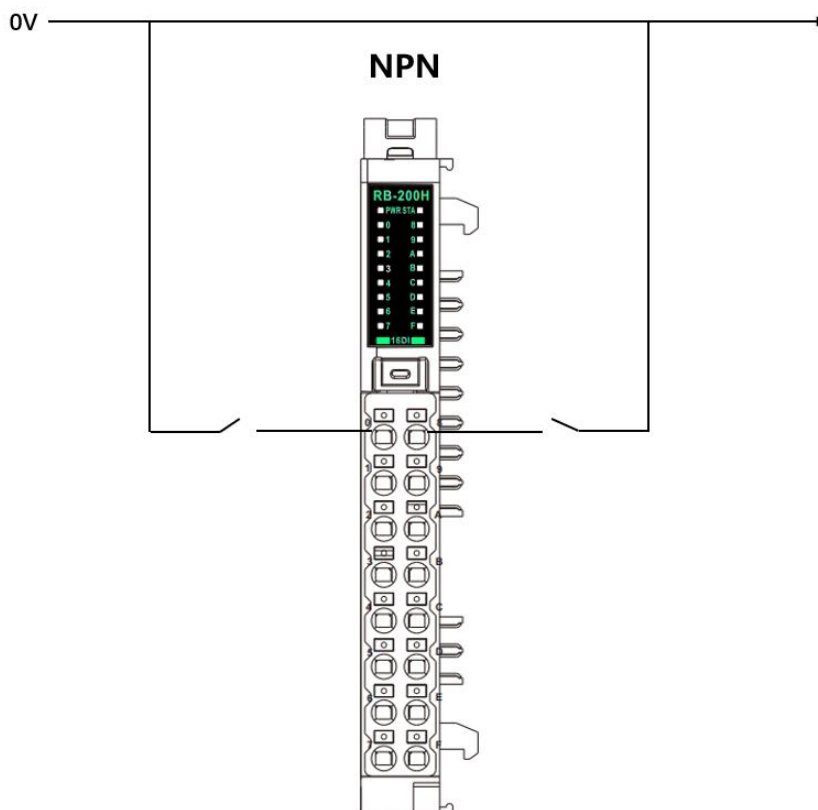

 Notice

● RB-2018 is NPN type with input signal 0V; 0V is delivered at the interface terminal. The sensor can be directly connected to the DI channel and the 0V port.

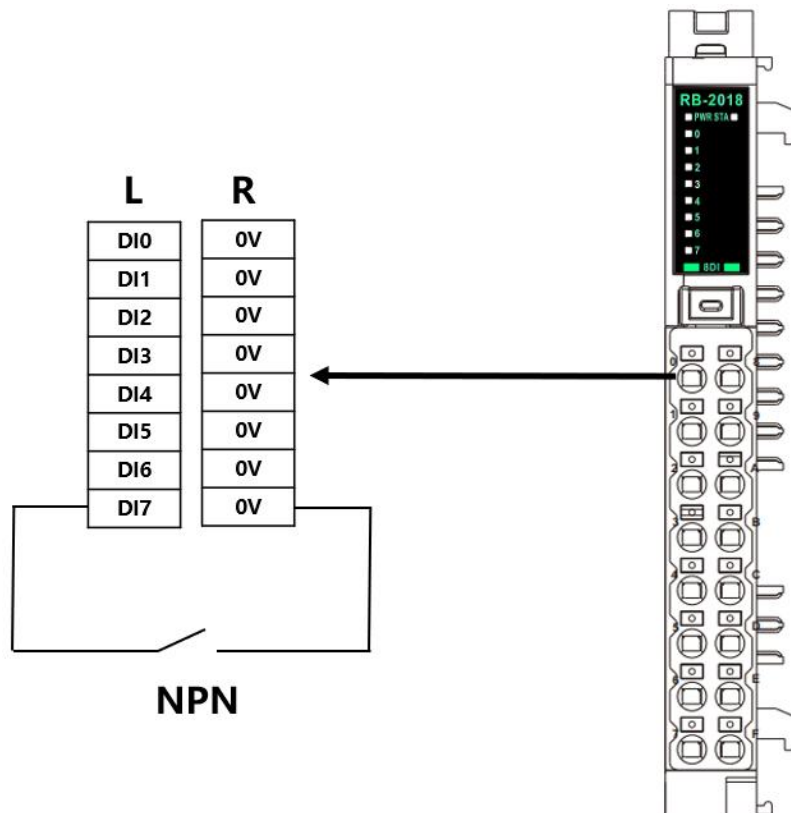

 Notice

- RB-210H PNP type, input signal 24V.

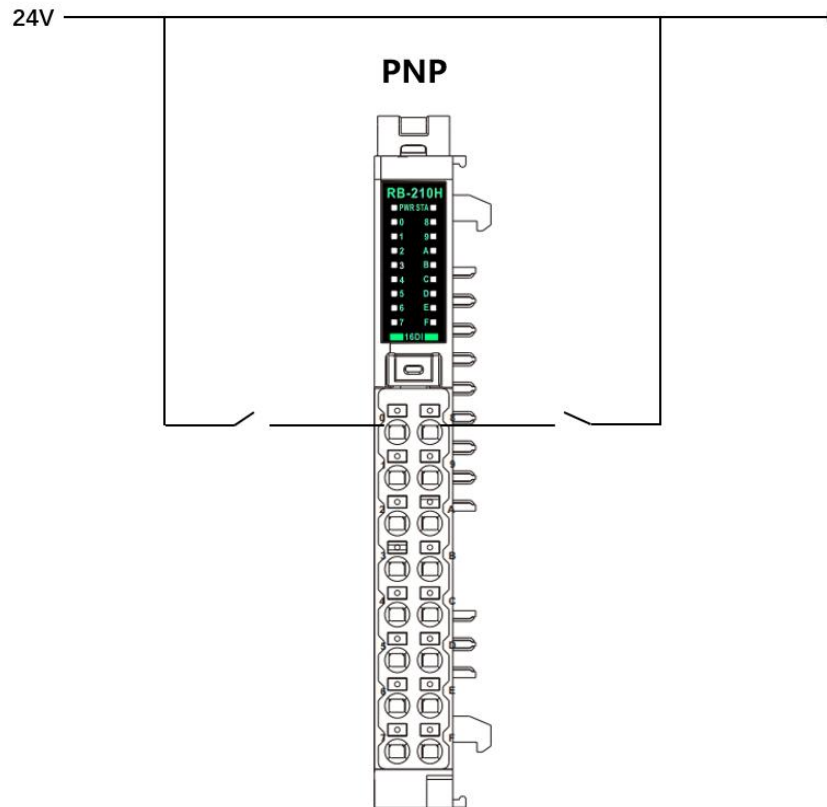

 Notice

●RB-2118 PNP type, input signal is 24V; 24V is delivered at the interface terminal.
The sensor can be directly connected to the DI channel and 24V port.

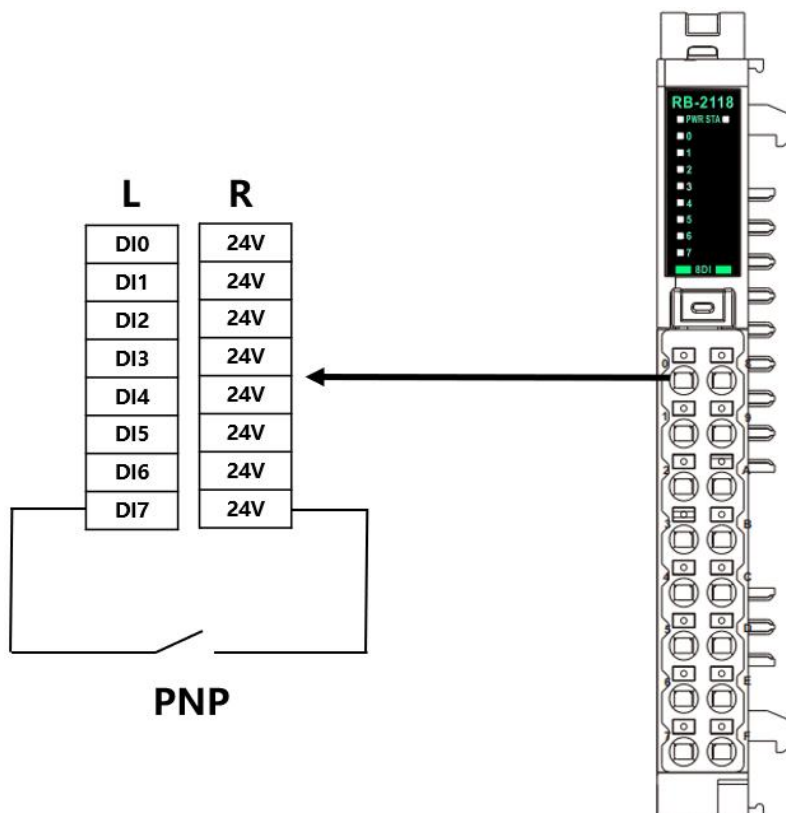

RB series I/O module

3.2.2 Digital output module wiring diagram

 **Notice**

- The RB-300H is an NPN type with an output signal of 0V.

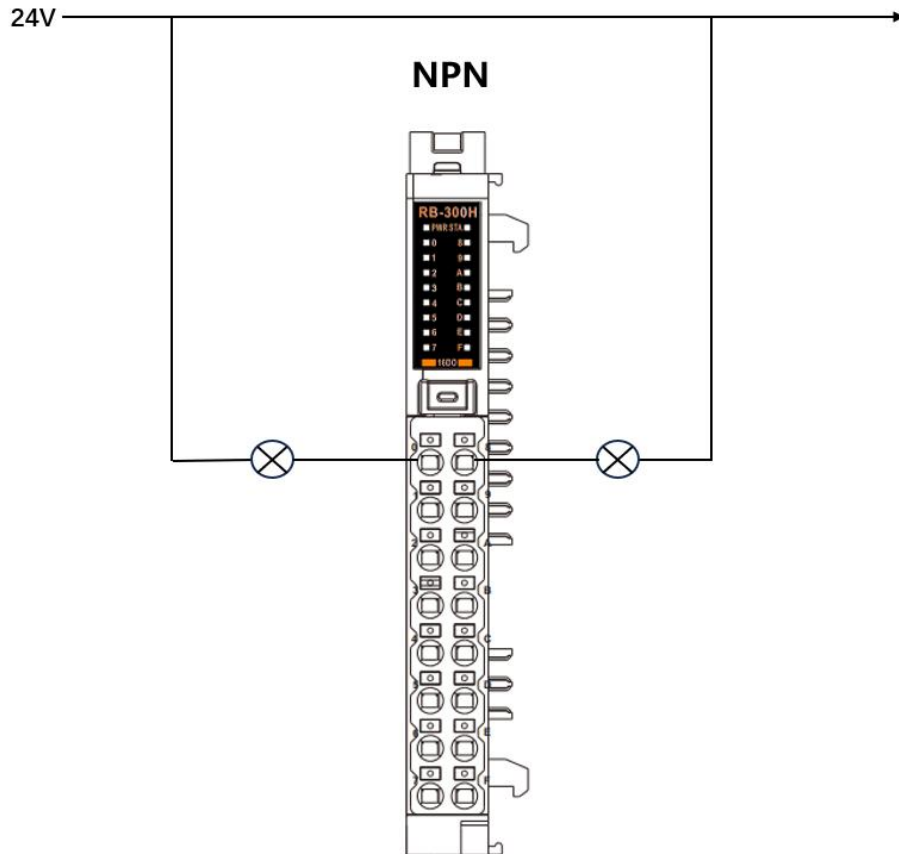

 Notice

● RB-3018 is an NPN type with an output signal of 0V; 24V is delivered at the interface terminal, and the load can be directly connected to the DO channel and 24V port.

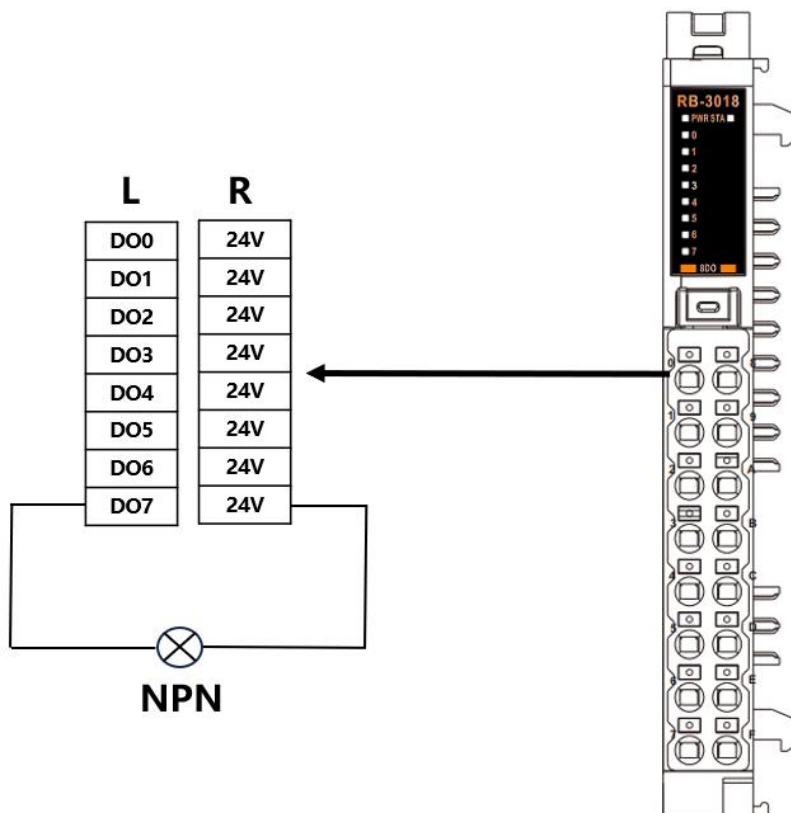

 Notice

- The RB-310H is a PNP with an output signal of 24V.

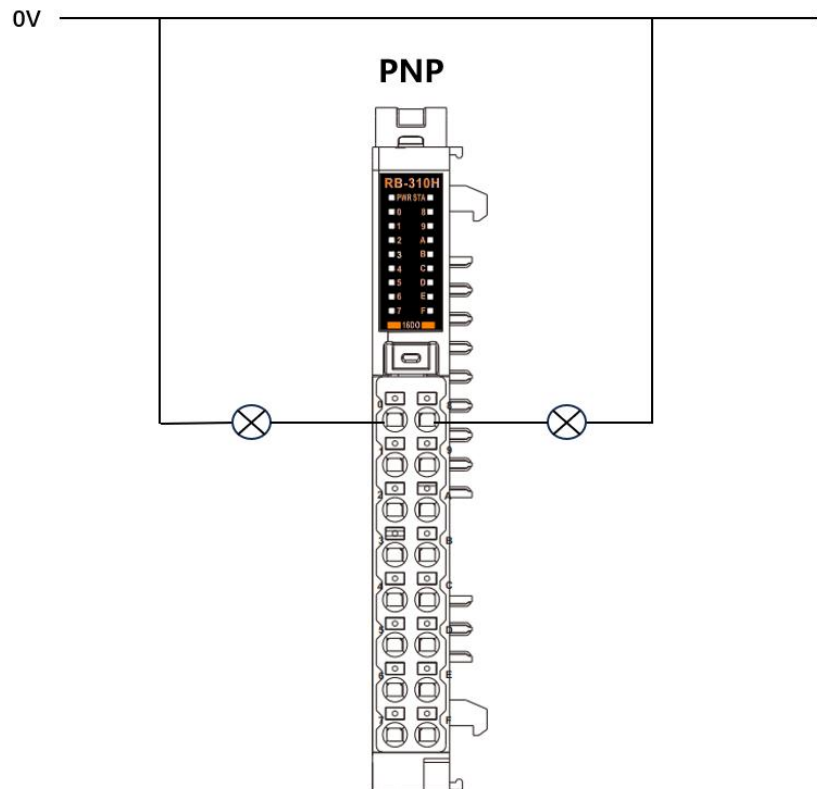

 Notice

●RB-3118 is PNP type, the output signal is 24V; 0V is delivered at the interface terminal, and the load can be directly connected to the DO channel and the 0V interface.

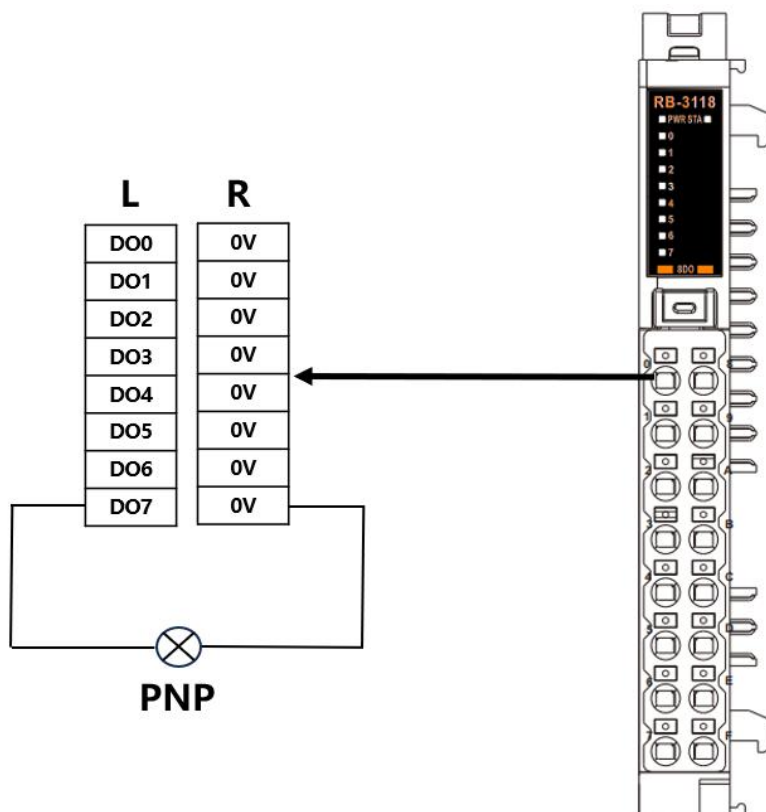

 Notice

●RB-3204 is the relay output, and the right channel is the COM end

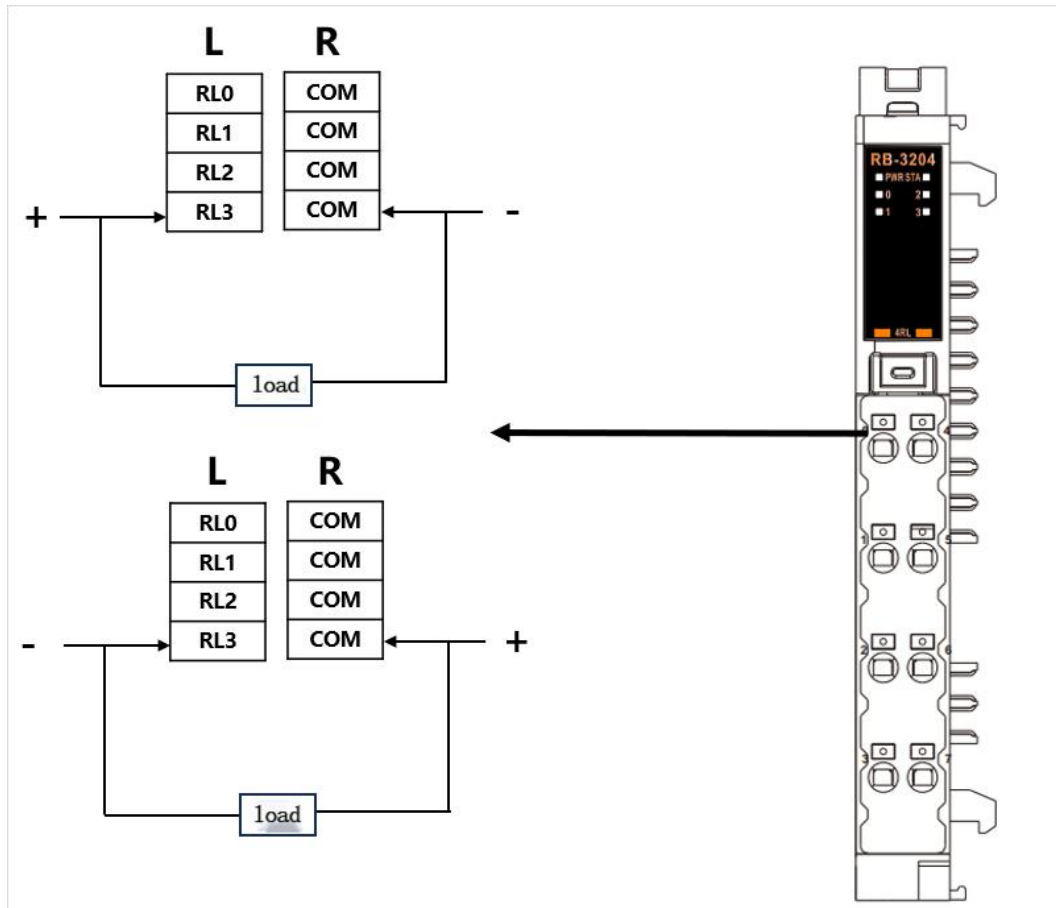

4. Module configuration information

4.1 Module input and output bytes

模块类型	输入字节数	输出字节数
8DI	1	—
16DI	2	—
8DO	—	1
16DO	—	2

4.2 The DO module supports single-channel alternative value configuration

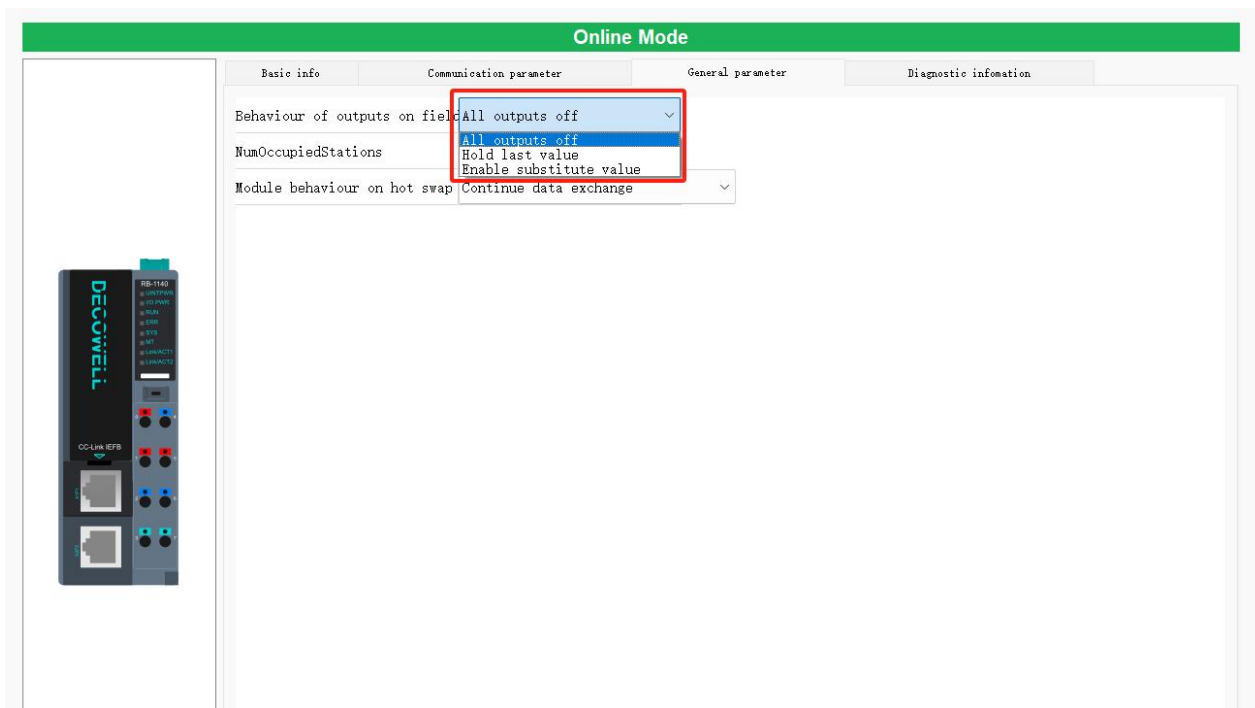

value	Description
All outputs off (Default value)	The output module status data is cleared
Hold last value	Keep last value
Enable substitute value	Start substitute value

Note: Whether to enable alternative values is set in the adapter



01

BASIC INFO	CONFIG-DATA	TXPDO
Ch 0: Substitute value	0	▼
Ch 1: Substitute value	0	▼
Ch 2: Substitute value	0	▼
Ch 3: Substitute value	0	▼
Ch 4: Substitute value	0	▼
Ch 5: Substitute value	0	▼
Ch 6: Substitute value	0	▼
Ch 7: Substitute value	0	▼
Ch 8: Substitute value	0	▼
Ch 9: Substitute value	0	▼
Ch A: Substitute value	0	▼
Ch B: Substitute value	0	▼
Ch C: Substitute value	0	▼
Ch D: Substitute value	0	▼
Ch E: Substitute value	0	▼
Ch F: Substitute value	0	▼

4.2 The DI module supports filtering configuration

The value ranges from 0.5 ms to 10ms. The default value is 3ms.

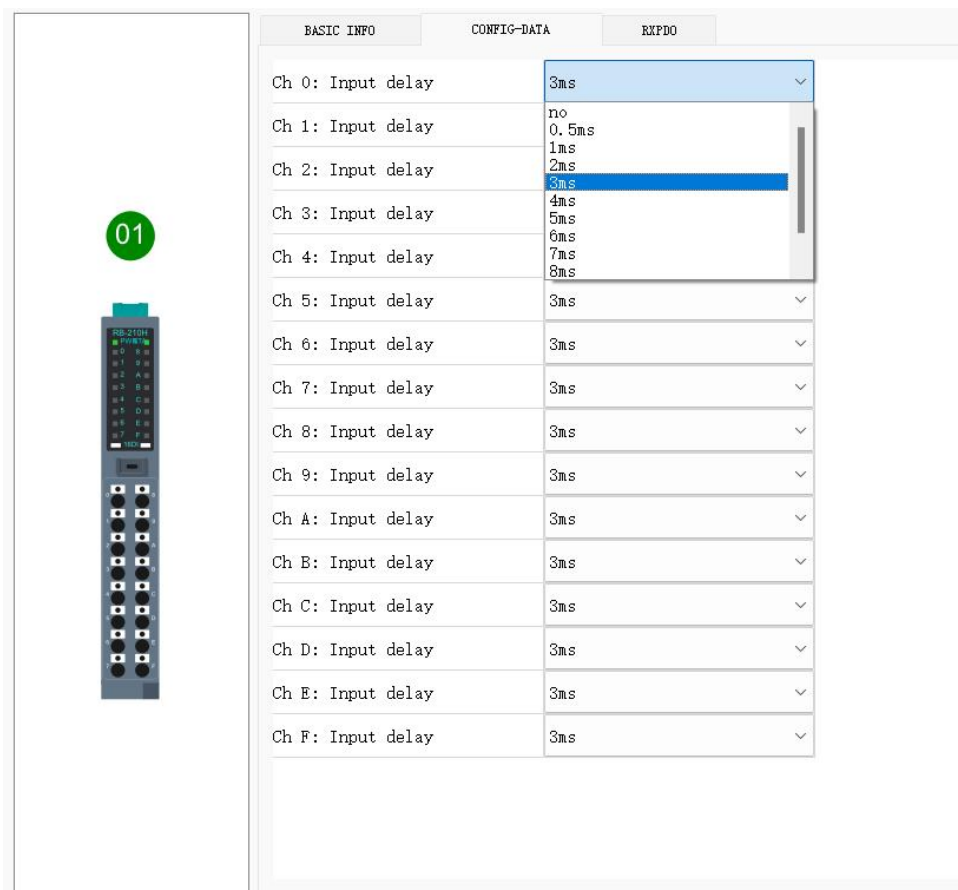

Note: After the above modification is complete, right-click the module, click Download configuration, power off and restart to take effect

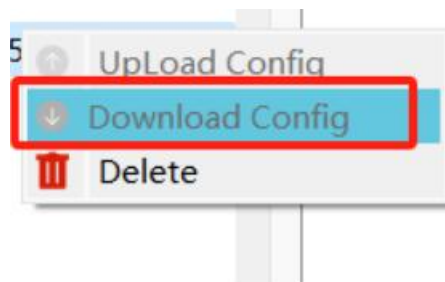

本手册如有参数更新, 恕不另行通知。



南京德克威尔自动化有限公司
Nanjing Decowell Automation Co., Ltd.

全国服务热线

400-0969016

地址: 南京市浦口区兰新路19号瑞创智造园13号楼

网址: www.wellinkio.com

邮箱: sales@wellinkio.com

