

RB系列I/O模块 用户手册

德克威尔 · 工业智造可靠伙伴



网址: www.wellinkio.com

邮箱: sales@wellinkio.com

地址: 南京市浦口区兰新路19号瑞创智造园13号楼

Preface

■ Brief introduction

Thank you for purchasing the Decowell RB Series card-type I/O modules!

RB Series card-type I/O modules is a distributed extension module developed by DECOWELL. This series module consists of adapter, I/O module, power module and terminal module. Adapters can support a variety of communication buses, Such as PROFINET、EtherCAT、CC-Link、Modbus TCP etc. I/O module can be divided into digital input module, digital output module, analog input module, analog output module and function module, users can be matched according to the actual application.

Analog input module and analog output module are commonly used I/O modules of RB series. Analog module is divided into input and output modules, according to the signal type is divided into voltage type and current type, according to the resolution is divided into 12 and 16 bits, according to the channel can be divided into 4 channels and 8 channels.

This manual mainly describes the specifications and features of the module. Please read it carefully before use so that you can use the product clearly and safely.

CONTENTS

Preface.....	2
Safety precautions.....	5
1.Product information.....	8
1.1 Analog input module.....	8
1.1.1 Product model information.....	8
1.1.2 Technical specification.....	13
1.2 Analog output module.....	15
1.2.1 Product model information.....	15
1.2.2 Technical specification.....	20
1.3 Environmental parameter.....	21
2.Mechanical installation.....	22
2.1 Installation dimensions.....	22
2.2 Installation method.....	23
2.2.1 Installation between modules.....	23
2.2.2 Installation on the guide rail.....	24

3. Electrical installation	24
3.1 Cable selection.....	25
3.2 Terminal wiring.....	26
3.2.1 Analog input 3-wire / 4-wire connection.....	26
3.2.2 Analog output module wiring diagram.....	28
4. About IOTesterTool use	29
4.1 How do I change analog channel parameters.....	29

Safety precautions

■ Safety statement

01. When installing, operating, and maintaining the product, read and follow these safety precautions.

02. To ensure the safety of the human body and the device, follow the labels on the product and all the safety precautions described in this document when installing, operating, and maintaining the product.

03. The “Tips”, “attention”, “warning” and “danger” in this manual do not represent all safety precautions to be followed, but only serve as a supplement to all safety precautions.

04. This product should be used in an environment that meets the requirements of the design specifications, otherwise it may cause failure, and the abnormal function or component damage caused by non-compliance with the relevant regulations are not within the scope of product quality assurance.

05. Due to the illegal operation of products caused by personal safety accidents, property damage, etc., Decowell does not assume any legal responsibility.

■ Security Level Definition

Tips

The mark indicates “necessary additions or clarifications to the description of the operation” .

Notice

The mark “Hazard caused by failure to perform as required, which could result in mild or moderate injury to human body and damage to equipment” .

 **Warning**

The mark indicates that “personal injury or death may result from hazards caused by failure to perform as required”.

■ During control system design ⚡ Warning

01. In the application, it is necessary to design a safety circuit to ensure that the control system can still work safely when the external power supply fails or the expansion module fails.

02. When the output circuit exceeds the rated load current or the load short circuit leads to long-term overcurrent, the module may smoke or catch fire, and safety devices such as fuses or circuit breakers should be set outside.

■ During control system design ⚠ Notice

01. The external circuit of the expansion module must be equipped with an emergency brake circuit, a protection circuit, an interlock circuit for forward and reverse operation and a position upper limit and lower limit interlock switch to prevent machine damage;

02. In order to ensure the safe operation of the equipment, please design external protection circuits and safety mechanisms for output signals related to major accidents;

03. When the relay, transistor and other output units of the expansion module are damaged, the output can not be controlled to ON or OFF state;

04. The expansion module is designed to be used in an indoor electrical environment with an overvoltage level II. The power system level of the expansion module should have a lightning protection device to ensure that the lightning overvoltage is not applied to the power input, signal input, and control output ports of the expansion module to avoid device damage.

1. Product information

1.1 Analog input module

The analog input module is divided into voltage type and current type. Voltage type input module can be switched to 4 ranges, respectively 0 ~ 10V, ±10V, 0 ~ 5V, ±5V; The current input module has two ranges that can be switched, which are 4 ~ 20mA and 0 ~ 20mA respectively. The resolution of the analog input module is 16bit (accuracy 0.05%).

1.1.1 Product model information

Model number	Specification description	Order number
RB-4054	4-channel voltage input, resolution 16bit, accuracy 0.05%, range ±10V, ±5V, 0 ~ 5V, 0 ~ 10V compatible, default 0 ~ 10V	18-05-01
RB-4454	4-channel current input, 16bit resolution, 0.05% accuracy, range 0 ~ 20mA, 4 ~ 20mA compatible, default 4 ~ 20mA	18-05-02

● Module channel indicator light

channel indicator light	status	definition
green	Flicker	have analog signal input
	Bright	Analog input overrange
	Extinguish	No analog signal input

● PWR/STA Indicator description



LED	status	description
STA	Blinking red (5HZ)	Module self-test exception (internal failure)
	Red light always on	The module does not communicate with the adapter, and the configuration information fails to be loaded
	Green light always on	Module working properly
	Blinking red at slow intervals (1HZ)	Module hardware exception
PWR	Green light always on	Internal power supply normal (5V system side)
	Green light off	No power supply or abnormal power supply (5V system)

RB series I/O module

- The analog range corresponds to the numerical value

Input type		Analog input value	
		Voltage mode	Current mode
Resolution	polarity	±10V, ±5V, 0 ~ 5V, 0 ~ 10V	0 ~ 20mA, 4 ~ 20mA
16-bit	unipolarity	0~32767, 0~27468, 0~30000	0~32767, 0~27468, 0~30000
	bipolar	-32767~32767, -27468~27468, -15000~15000	-32767~32767, -27468~27468, -15000~15000

- Analog voltage input module digital-analog curve (0 ~ 30000/-15000 ~ 15000 for example)

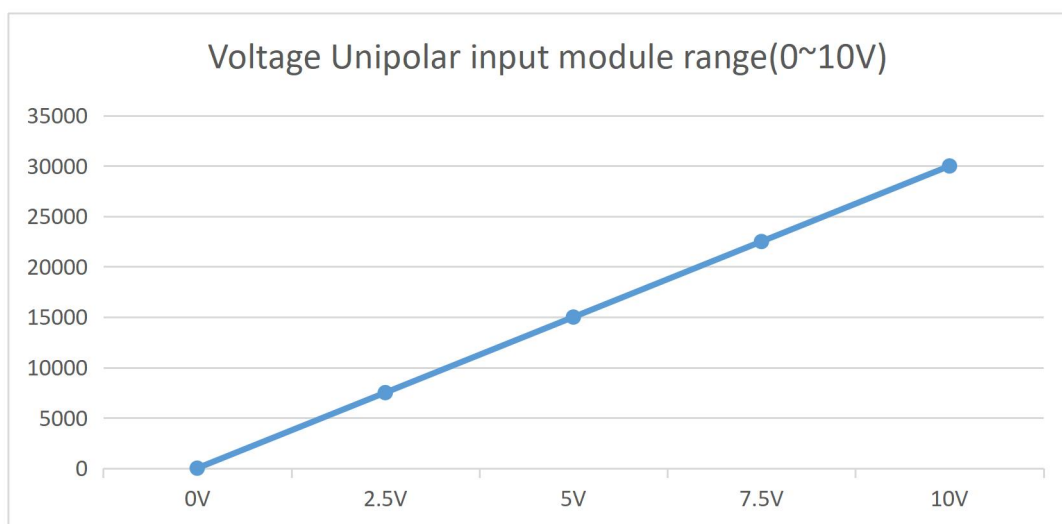

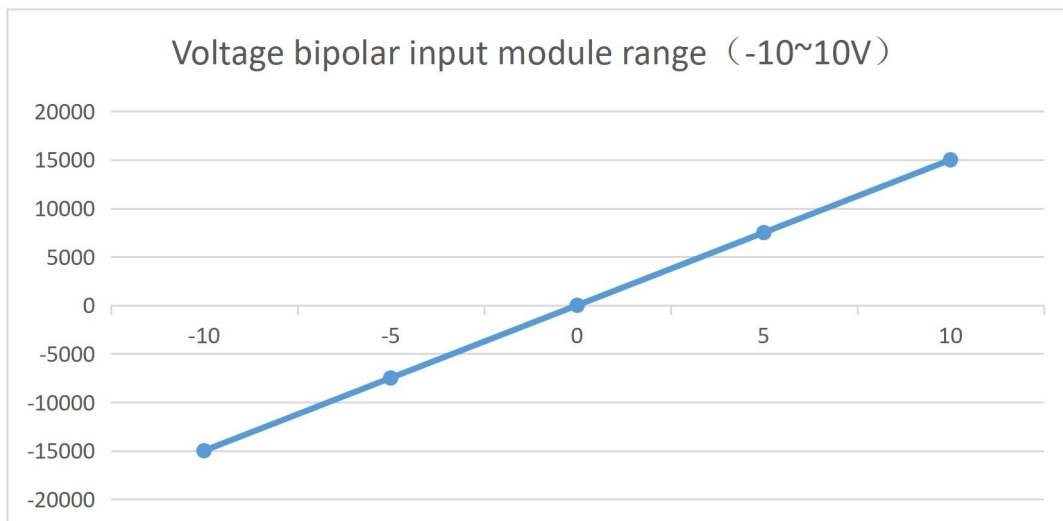

● Analog current type input module digital-analog curve

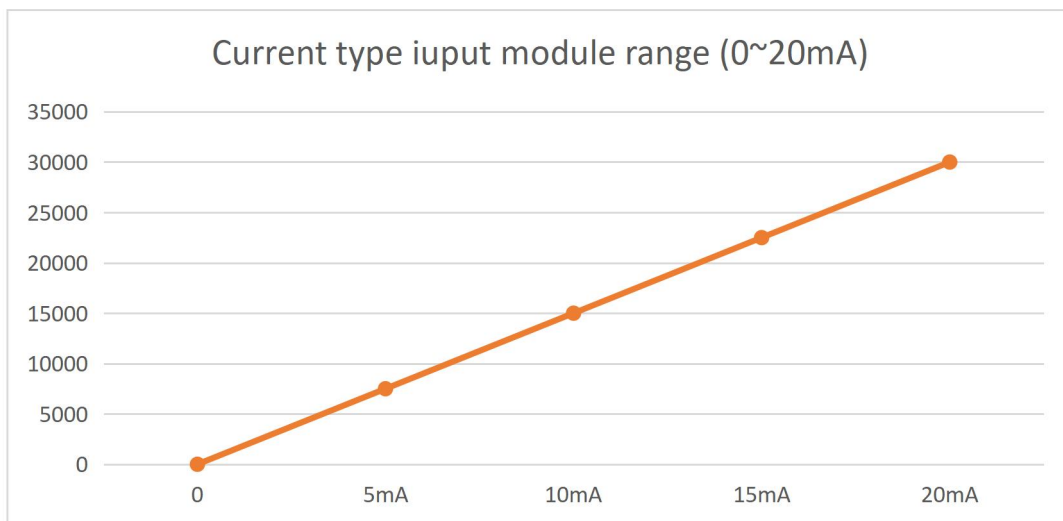

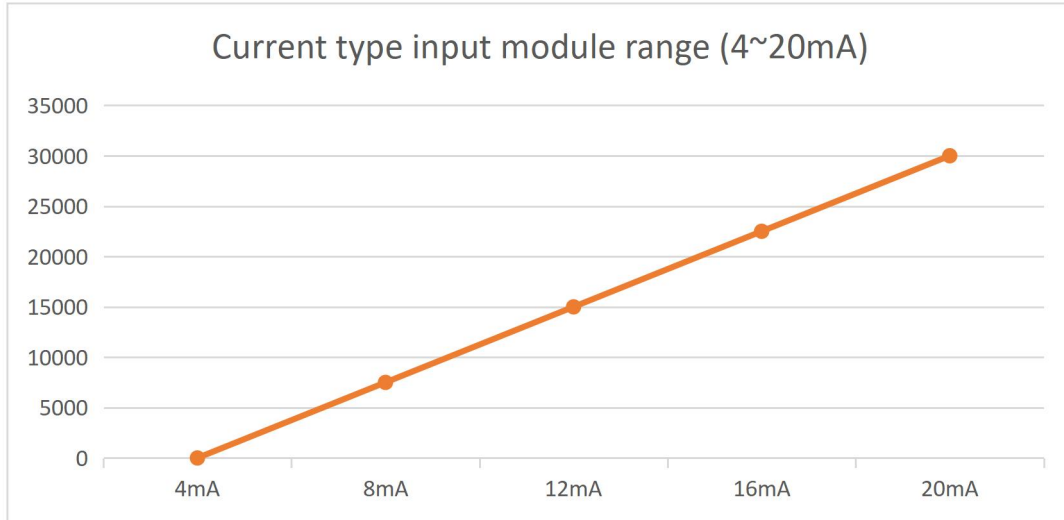

- 16-bit 4-20mA digital-to-analog conversion formula (X is the current value, Y is the value corresponding to the current value) :

$$\frac{X - 4}{20 - 4} = \frac{Y}{30000}$$

- 16-bit 0-20mA digital-to-analog conversion formula (X is the current value, Y is the value corresponding to the current value) :

$$\frac{X}{20} = \frac{Y}{30000}$$

- 16-digit 0-10V digital-to-analog conversion formula (X is the voltage value, Y is the value corresponding to the current voltage value) :

$$\frac{X}{10} = \frac{Y}{30000}$$

- 16-digit 0-5V digital-to-analog conversion formula (X is the voltage value, Y is the value corresponding to the current voltage value) :

$$\frac{X}{5} = \frac{Y}{30000}$$

- 16-bit ±10V digital-to-analog conversion formula (X is the voltage value, Y is the value corresponding to the current voltage value) :

$$\frac{X}{10/-10} = \frac{Y}{15000/-15000}$$

RB series I/O module

1.1.2 Technical specification

- Enter module parameters

Technical parameter		
Model number	RB-4054	RB-4454
Product name	Analog input module	
Signal type	$\pm 10V$, $\pm 5V$, $0\sim 5V$, $0\sim 10V$	$0\sim 20mA$, $4\sim 20mA$
Power dissipation	82mA	82mA
Input characteristic		
Input channel number	4	
Input filtering	Configurable: Level 0 ~ 3 (default 1)	
Conversion speed	The minimum channel conversion time is 40us	
Input impedance	$>500K\ \Omega$	$100\ \Omega$
Resolution	16-bit	
precision	0.05%	
Absolute maximum input	$\pm 15V$	30mA
Overvoltage protection	support	
Isolated withstand voltage	AC500V on the field side and the digital side. Channels are not isolated	
Physical parameter		
Size specification	100mm×77mm×12mm	

RB series I/O module

Operating temperature	-20~55℃
Class of protection	IP20
Wiring specification	0.2~1.5mm ²
Connection mode	screw-free
weight	70g

1.2 Analog output module

Analog output module is divided into voltage type and current type. Voltage type output module can be switched to 4 output ranges, respectively 0 ~ 10, $\pm 10V$, 0 ~ 5V, $\pm 5V$; Two output ranges of current mode output module can be switched, respectively 0 ~ 20mA, 4 ~ 20mA. The analog output module has a resolution of 16bit (0.05% accuracy).

1.2.1 Product model information

Model number	Specification description	Order number
RB-5054	4 channel voltage output, resolution 16bit, accuracy 0.05%, range $\pm 10V$, $\pm 5V$, 0 ~ 5V, 0 ~ 10V compatible, default 0 ~ 10V	18-07-01
RB-5454	4-channel current output, 16bit resolution, 0.05% accuracy, range 0 ~ 20mA, 4 ~ 20mA compatible, default 4 ~ 20mA	18-07-02

RB series I/O module

● Module indicator lights

Channel indicator light	status	definition
Green	flicker	Have Analog signal output
	Bright	Analog input overrange
	Extinguish	No analog signal output

● PWR/STA Indicator description



LED	status	description
STA	Blinking red (5HZ)	Module self-test exception (internal failure)
	Red light always on	The module does not communicate with the adapter, and the configuration information fails to be loaded
	Green light always on	Module working properly

RB series I/O module

	Blinking red at slow intervals (1HZ)	Module hardware exception
PWR	Green light always on	Internal power supply normal (5V system side)
	Green light off	No power supply or abnormal power supply (5V system)

- The analog range corresponds to the numerical value

Output type		Analog output value	
		Voltage mode	Current mode
Resolution	polarity	$\pm 10V, \pm 5V, 0 \sim 5V, 0 \sim 10V, 1 \sim 5V$	$0 \sim 20mA, 4 \sim 20mA$
16-bit	unipolarity	$0 \sim 32767, 0 \sim 27468, 0 \sim 30000$	$0 \sim 32767, 0 \sim 27468, 0 \sim 30000$
	bipolar	$-32767 \sim 32767, -27468 \sim 27468, -15000 \sim 15000$	$-32767 \sim 32767, -27468 \sim 27468, -15000 \sim 15000$

- Analog voltage output module digital-analog curve (0~30000/-15000~15000 examples)

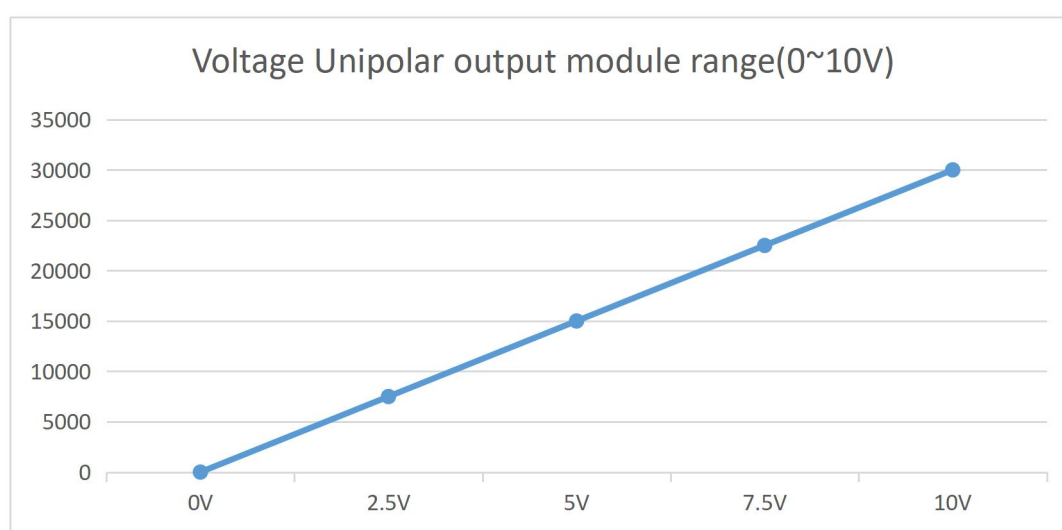

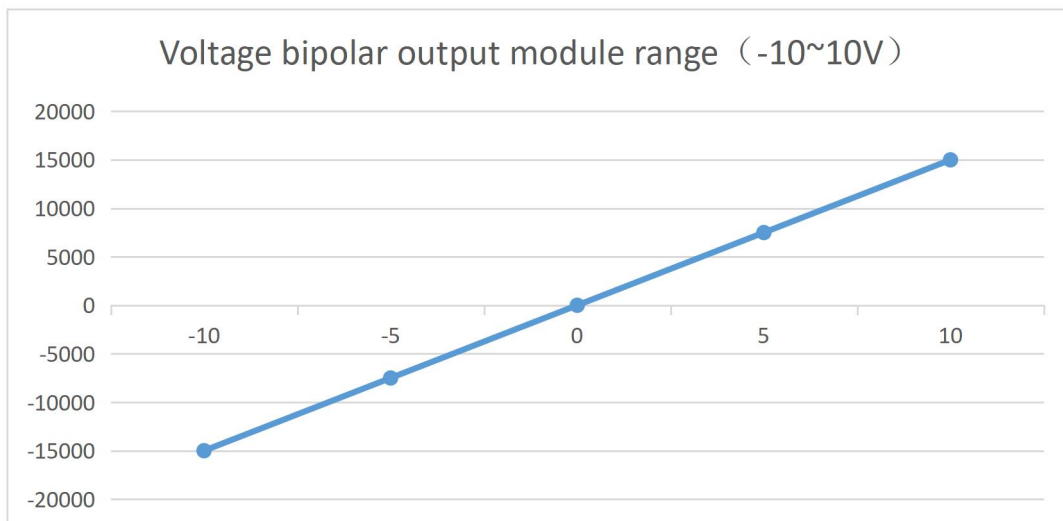

● Analog current output module digital analog curve

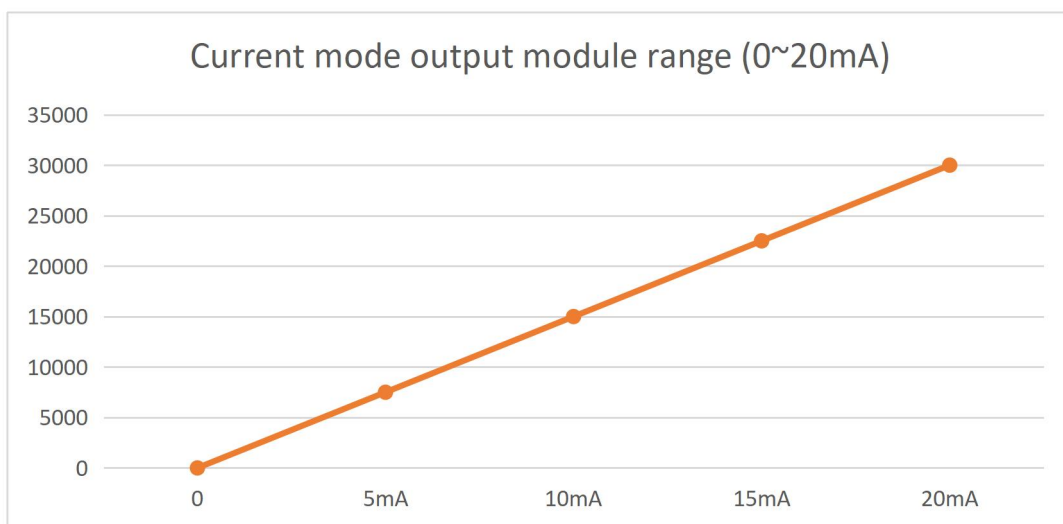

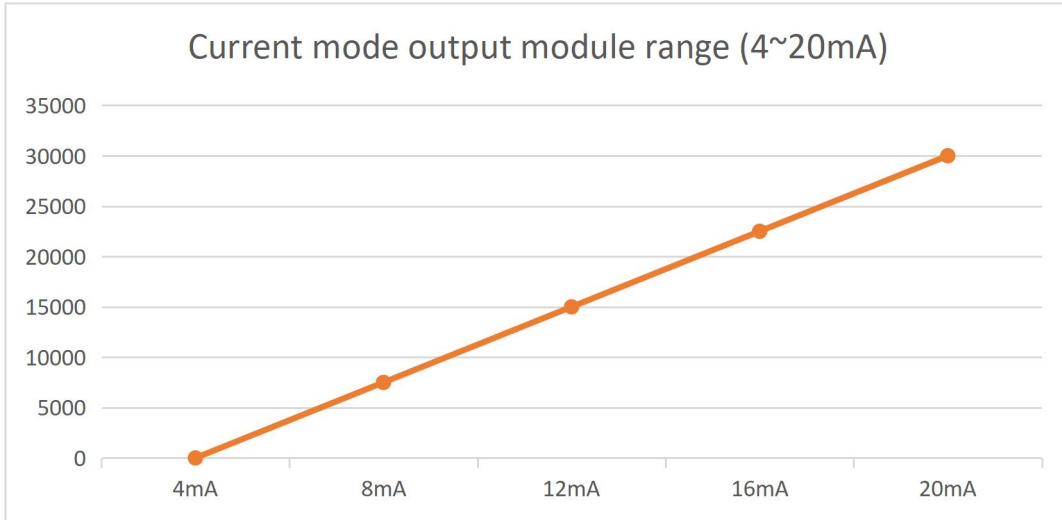

- 16-bit 4-20mA digital-to-analog conversion formula (X is the current value, Y is the value corresponding to the current value) :

$$\frac{X - 4}{20 - 4} = \frac{Y}{30000}$$

- 16-bit 0-20mA digital-to-analog conversion formula (X is the current value, Y is the value corresponding to the current value) :

$$\frac{X}{20} = \frac{Y}{30000}$$

- 16-digit 0-10V digital-to-analog conversion formula (X is the voltage value, Y is the value corresponding to the current voltage value) :

$$\frac{X}{10} = \frac{Y}{30000}$$

- 16-digit 0-5V digital-to-analog conversion formula (X is the voltage value, Y is the value corresponding to the current voltage value) :

$$\frac{X}{5} = \frac{Y}{30000}$$

- 16-bit ±10V digital-to-analog conversion formula (X is the voltage value, Y is the value corresponding to the current voltage value) :

$$\frac{X}{10/-10} = \frac{Y}{15000/-15000}$$

RB series I/O module

1.2.2 Technical specification

- This section describes the output module parameters

Technical parameter		
Model number	RB-5054	RB-5454
Product name	Analog output module	
Signal type	±10V, ±5V, 0~5V, 0~10V	0~20mA, 4~20mA
Power dissipation	24mA	21mA
Input characteristic		
Output channel number	4	
Output impedance	>10K Ω	<100 Ω
Maximum channel conversion time	The maximum channel conversion time is 10us	
Resolution	16-bit	
precision	0.05%	
Overvoltage protection	support	
Isolated withstand	AC500V on the field side and the digital side. Channels are not isolated	
Physical parameter		
Size specification	100mm×77mm×12mm	
Operating temperature	-20~55℃	
Class of protection	IP20	

RB series I/O module

Wiring specification	0.2~1.5mm ²
Connection mode	screw-free
weight	70g

1.3 Environmental parameter

Environmental parameter	
Operating temperature	-20~55℃
Working humidity	95% non-condensing
atmosphere	≥ 795 hPa (altitude ≤ 2000 m) as per IEC 61131-2
Storage temperature	-40~+70℃
Overvoltage class	I

2. Mechanical installation

2.1 Mounting dimension

The installation dimensions are shown in the following figure (unit: mm).



- The dimensions below apply to analog input/output modules.

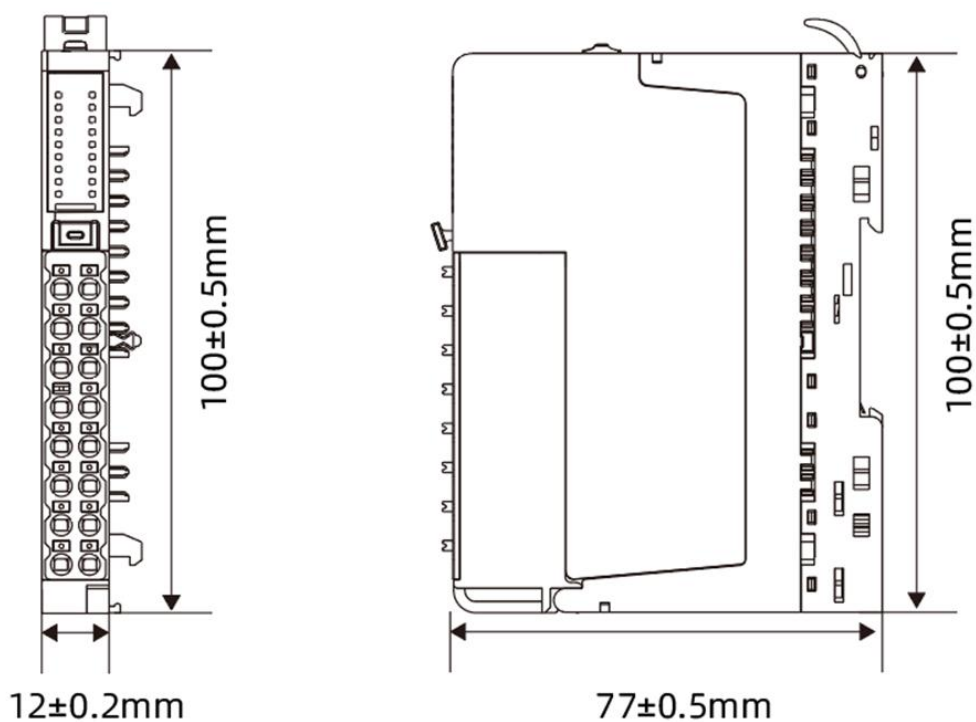

2.2 Installation method

2.2.1 Intermodule installation

The intermodule assembly is installed through the locking joystick on the top of the module, as shown below

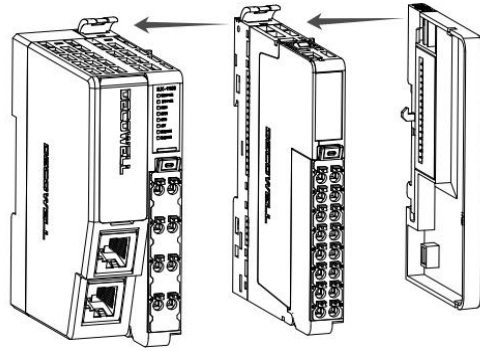

The modules are mounted on DIN rails, which comply with IEC 60715 standards (35mm wide, 1mm thick), dimensional information.

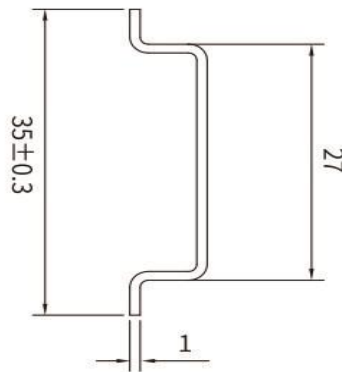

Note: The DIN rail latch may not lock properly when the module is installed on a rail other than the recommended DIN35 rail. Before installing the module, open the lock lever on the top of the module, and then proceed to the next step.

Notice

- When the product is installed on a DIN rail other than the recommended one (especially if the thickness of the DIN rail is less than 1.0mm), the DIN rail lock will fail, and the product will not be installed in place, resulting in the product not working properly.

2.2.2 Installation on the guide rail

During installation, align the module with the DIN35 guide rail and press the module in the direction indicated by the arrow, as shown in the figure below.

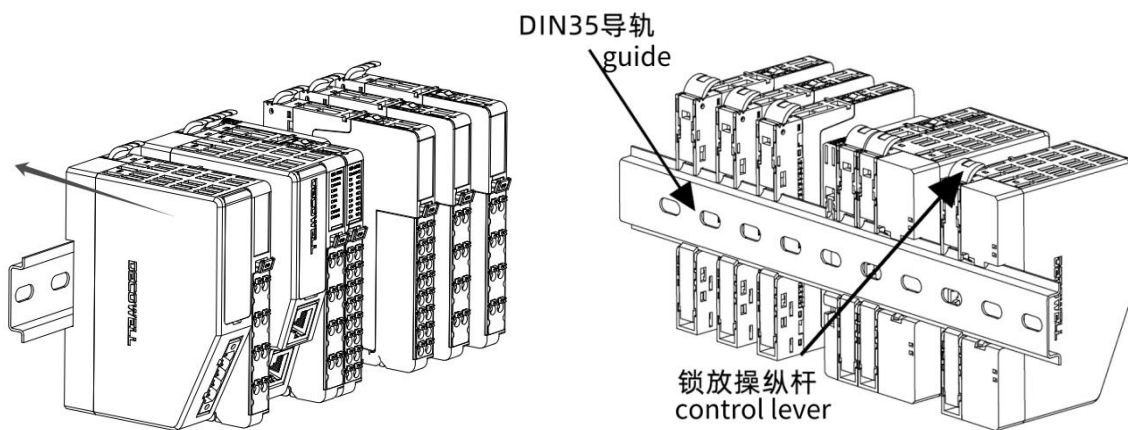

Note: After the module is installed, press down the locking lever to fix the module to the guide rail to ensure that the module is installed in place.

disassembly:

Use your hand to push the lock up on the joystick and pull the module away from the DIN35 guide rail.

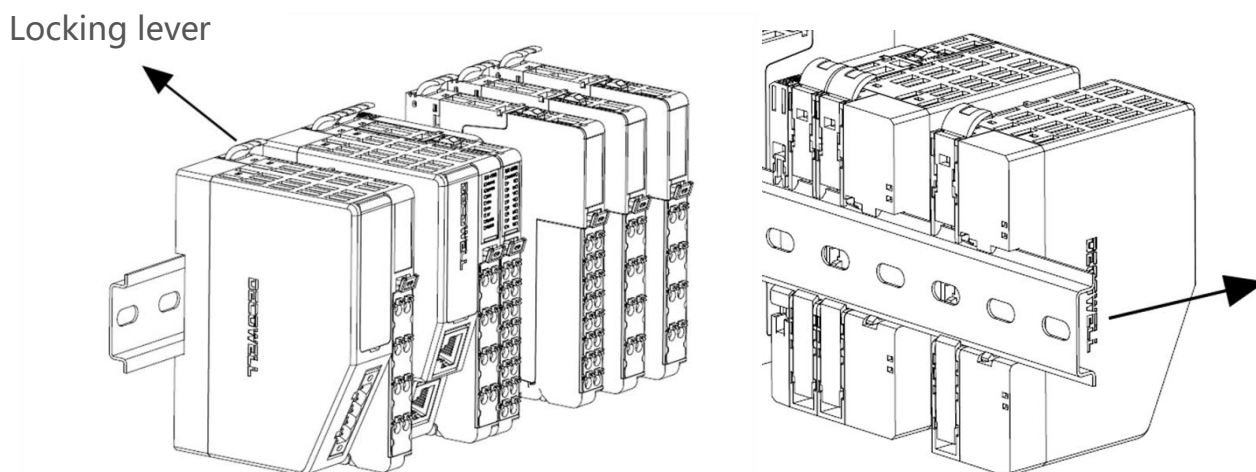

3. Electrical installation

3.1 Cable selection

For power cables, the ear diameters in the following table are for reference only. You can calculate and adjust them based on actual use

name	Fitting diameter	
	National standard/mm ²	American standard/AWG
Tubular lug	0.75	18
	1.0	18
	1.5	16

The following figure shows the shapes and dimensions of riveting terminals:

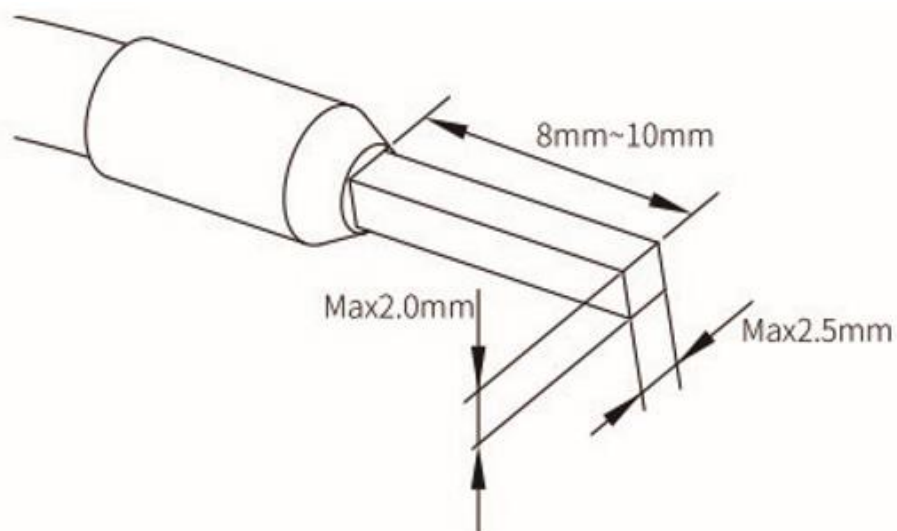

3.2 Terminal connection



- RB series analog input modules support 2/3/4 wire connection

3.2.1 Analog input (RB-4054/RB-4454) 3-wire / 4-wire connection

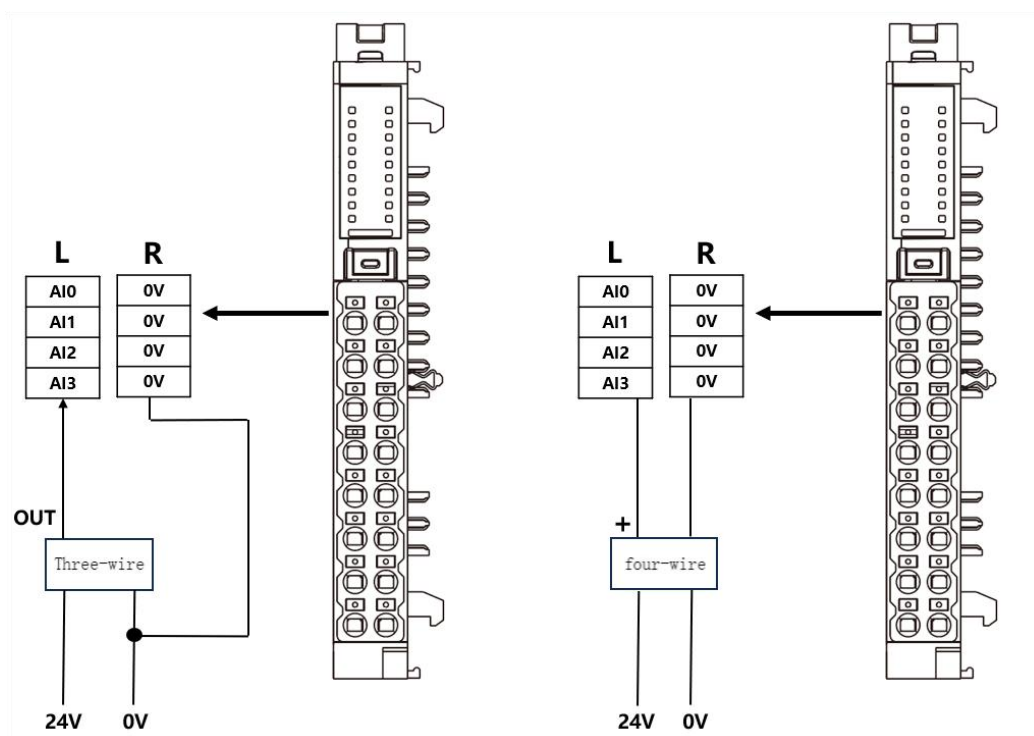

RB series I/O module

- RB-4054 module wiring diagram is shown in the figure
- RB-4454 module wiring diagram is shown in the figure

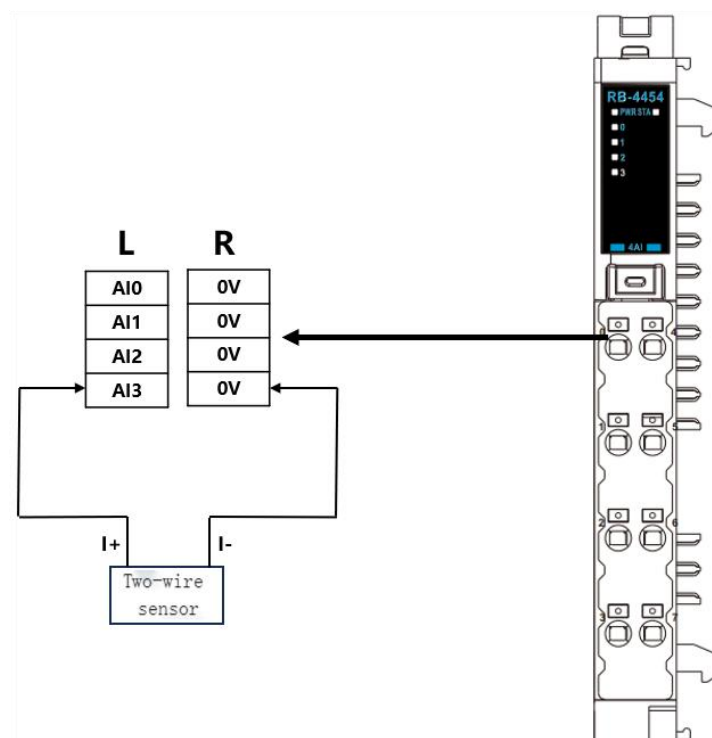
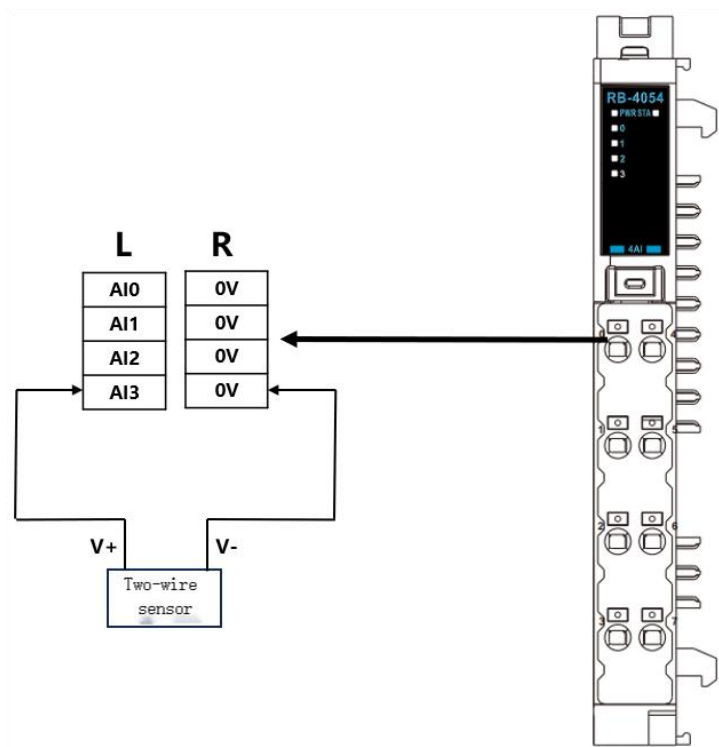

RB series I/O module

3.2.2 Analog output module wiring diagram

- RB-5054 module wiring diagram is shown in the figure
- RB-5454 module wiring diagram is shown in the figure

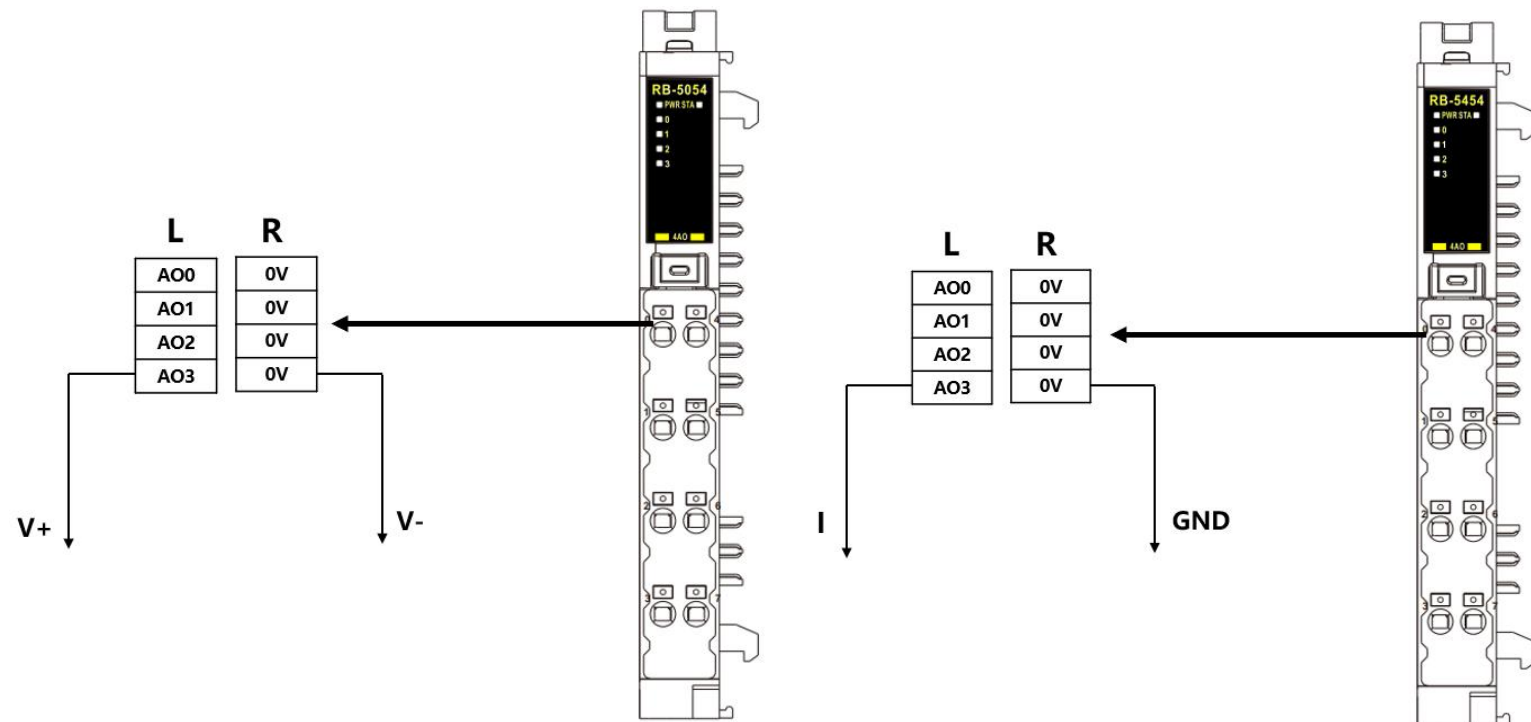

4. Module configuration information

4.1 How do I change analog channel parameters

Open the Decowell IOTesterTool software

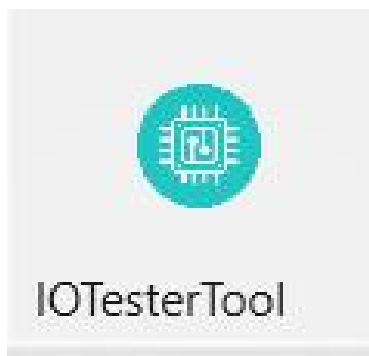

Click on the selected area in the image below to create a new project.

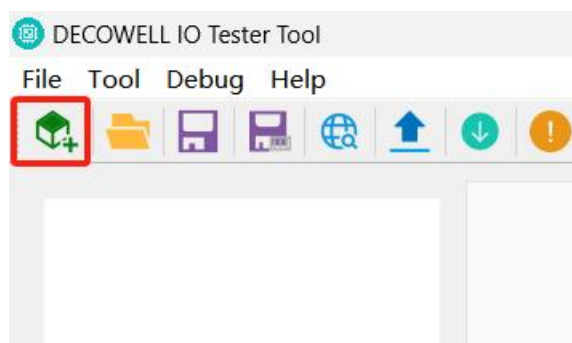

Right-click the created project and click "Scan Adapter"

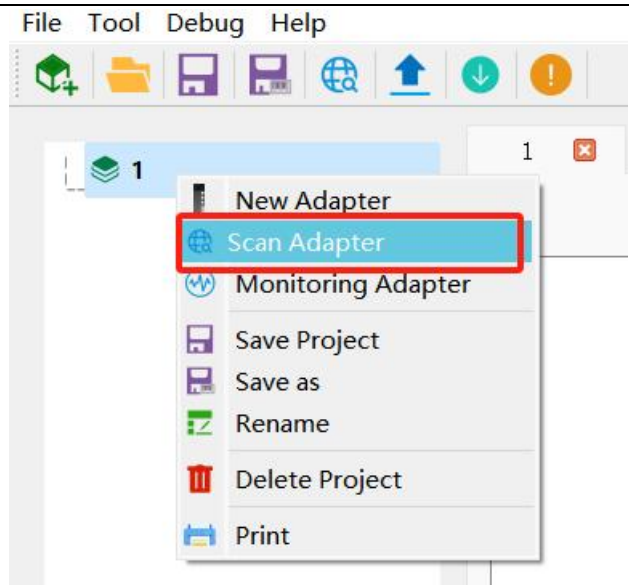

Select communication mode after scanning the module and add it to the project. Click the module in the left item bar and find the window "Connection parameters" to modify the module parameters.

Analog input

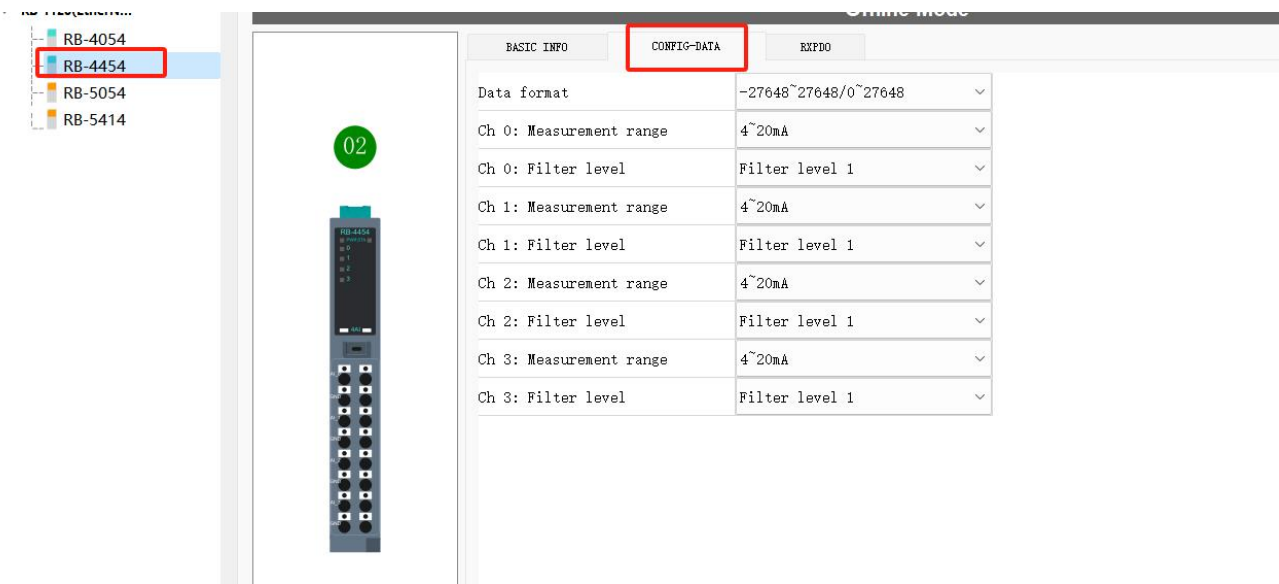

Analog output

Note: Whether to enable the alternative value function needs to be set in the adapter

Right-click the module and click Download Configuration to download the configuration parameters to the module. The parameters take effect after the power is powered off and the system restarts

本手册如有参数更新, 恕不另行通知。



南京德克威尔自动化有限公司
Nanjing Decowell Automation Co., Ltd.

全国服务热线

400-0969016

地址: 南京市浦口区兰新路19号瑞创智造园13号楼

网址: www.wellinkio.com

邮箱: sales@wellinkio.com

